



**I.D. MOUNT BOILER TUBE BEVELER TOOLS
 QUICK REFERENCE SETUP & OPERATION
 INSTRUCTIONS “SB”, “MB”, “LB” MODELS
 PN# 70-MAN-01**

SAFETY INSTRUCTIONS

READ AND UNDERSTAND ALL SAFETY INSTRUCTIONS BEFORE ATTEMPTING TO SET UP OR OPERATE ANY MACHINE TOOL!



INSPECT MACHINE & ACCESSORIES FOR WEAR AND DAMAGE

KEEP HANDS & CLOTHING CLEAR OF ROTATING PARTS

HEED ALL WARNINGS AND CAUTIONS

SECURE LOOSE CLOTHING & JEWELRY

KEEP WORK AREA CLEAR

ALWAYS DISCONNECT POWER SOURCE WHEN BEVEL IS COMPLETED



CLAMP LEG CHART

SB	
Leg Set #	I.D. Range
70-400-01	.69”-.90”
70-400-02	.86”-1.08”
70-400-03	1.04”-1.27”
70-400-04	1.23”-1.45”
70-400-05	1.41”-1.64”
70-400-06	1.60”-1.82”

MB	
Leg Set #	I.D. Range
71-400-01	1.0”-1.32”
71-400-02	1.25”-1.56”
71-400-03	1.49”-1.80”
71-400-04	1.73”-2.05”
71-400-05	1.93”-2.30”
-----	-----
	Optional
71-400-06	2.22”-2.55”
71-400-07	2.47”-2.79”
71-400-08	2.72”-3.04”

LB	
*Leg Set #	I.D. Range
72-400-01	1.25”-1.71”
72-400-02	1.61”-2.08”
72-400-03	1.97”-2.45”
72-400-04	2.34”-2.82”
72-400-05	2.71”-3.19”
	**LB Extended Range Leg Set
72-400-06	3.09”-3.56”
72-400-07	3.46”-3.93”
72-400-08	3.83”-4.31”

*Leg Set Includes 3 Leg & 1 Spring
 **REQUIRES EXTEND RANGE TOOL HEAD ASSEMBLY PART NO. 72-404-00

TOOLING

DESCRIPTION	PART NUMBER
37-1/2 DEGREE BEVEL TOOL BIT	70-700-00
FACING TOOL BIT	70-701-00

To place an order or to get more detailed information on this and other E.H. Wachs products, call us at:

1-800-323-8185 in the USA or 847-537-8800 Worldwide

Visit us on the Web at: www.ehwachs.com



END PREP TOOL COMPONENT DESCRIPTION

1. Feed Ratchet
2. Clamp Ratchet
3. Air Motor Trigger
4. Tool Bit Disk
5. Clamp Leg Set
6. Draw Bar
7. Draw Bar Retainer
8. Mandrel Shaft

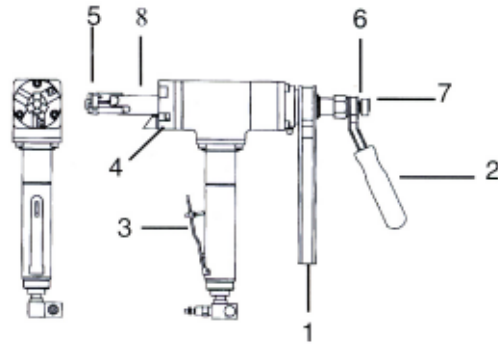

SETUP INSTRUCTIONS

LEG INSTALLATION PROCEDURE

MODELS SB, MB & LB

NOTE: To determine which leg set is required, measure the work piece pipe I.D. Refer to the Leg Chart. Each leg set is stamped with a reference number which corresponds to the pipe I.D. range, which the leg set will accommodate. (see clamp leg chart)



1. Remove draw bar retainer.



2. Remove draw bar using the clamp ratchet.



3. Slide the clamp leg set onto the draw bar and slip leg set over draw bar head slots.



4. Reinstall draw bar and retainer.

TOOL BIT INSTALLATION

1. Loosen tool bit wedge screw with the provided hex key. Slide tool bit to desired position and snug the tool bit wedge screw.



OPERATION

Insert the clamp leg end of the mandrel into the work piece. Tension the clamp legs by turning the clamp ratchet on the rear of the tool clockwise. **CAUTION:** Over tightening of the clamp leg draw bar can result in draw bar assembly breakage. Connect air supply to the tool. Be sure to use an in-line oiler/Regulator/Filter and verify the maximum 90 psi. Squeeze air motor trigger and turn the feed ratchet clockwise. Always attempt continuous pressure and feed until desired bevel is achieved. While tool is still rotating, turn feed ratchet counterclockwise to relieve tool pressure. Release air motor trigger, disconnect power source, and release clamp legs by turning clamp ratchet counterclockwise.

