

**SUPER C
 MODEL D
 SUPER D
 GOLIATH®**

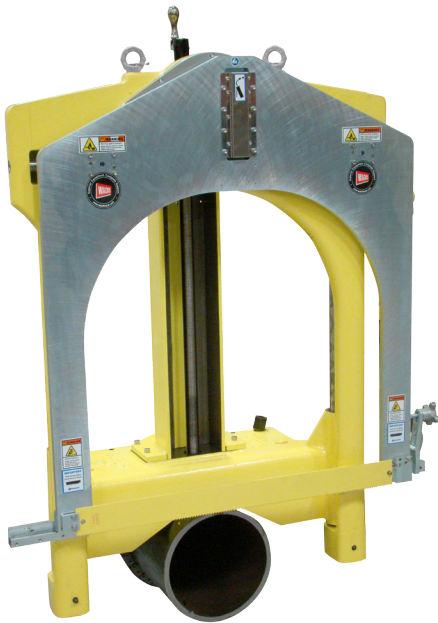

DESCRIPTION

E.H. Wachs family of portable Guillotine® reciprocating saws are designed to cold cut 2" through 32" (DN50-800) pipe, conductors, structures and solids such as beams, bar stock and rails. The four Guillotine models available from smallest to largest are the Super C, Model D, Super D and Goliath®. They provide fast, accurate cutting for contractors, water departments, gas companies, refineries, petrochemical and processing plants, and anywhere a fast simple cut is needed. In use virtually everywhere, they're strong yet light, simple to mount, simple to operate and simply bulletproof.

The Guillotine's rugged steel and aluminum construction is designed to deliver years of trouble free, reliable service. All Guillotines use an orbital cutting motion that lifts the blade on the return stroke, dramatically extending blade life. And when the cutting blades finally do need changing, they're easily replaced. Since its introduction in 1953 E.H. Wachs Guillotines have remained the benchmark in industrial grade reciprocating saws. It's no wonder that when pipe saws are first mentioned, the "Wachs Saw" is mentioned first.

EASY SETUP & OPERATION

Wachs Guillotine saws set up quickly, using a positive chain mounting system with a machined cast iron "V" saddle for perfectly square cuts. They can be mounted horizontally, vertically or anywhere in between, and come standard with finger-tip feed control for ease of operation. The saws require minimal operating clearances, in fact as little as 2.5" (63.5mm) to one side of a Super C.

Available with pneumatic and hydraulic drive motor options, select Guillotine models including the Goliath can be optionally equipped with autofeed or autoclamping mechanisms (with Rapid Retract), or with both. This allows the machine to be remotely controlled from a distance via Wachs Manifolds or by the UCP-3 Universal Control Panel that controls the feed rate, the cutting speed and the clamping hydraulics.

HIGHLY VERSATILE

No matter which Guillotine pipe saw you select, you're acquiring the most versatile reciprocating saw on the market today. With the power to saw through most materials, and the ability to be easily modified for unusual, difficult or dangerous cutting operations, there's a Guillotine right for you. From simple to difficult, pipe to solids, carbon to stainless, safe to hazardous, above water or below, whatever the cutting task Wachs has a Guillotine pipe saw for the job.

FEATURES

- Rugged yet compact design requires minimal clearances
- Four models cut from 2" to 32" (DN50-800)
- Easy fingertip feed control, quick change blades
- Fast setup and cutting, both horizontally and vertically
- Pneumatic and hydraulic drive options
- Optional autofeed and autoclamping on select models

THE LEGENDARY WACHS SAW



Guillotine saws feature fast, easy operation and the ability to cut most materials

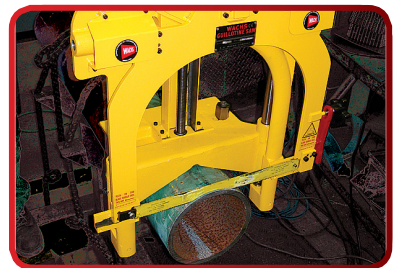

Quickly cuts through pipe with an orbital cutting motion that extends blade life



Guillotine saw shown with custom saddle for cutting steel I-beams, others available

E.H. WACHS

600 Knightsbridge Parkway | Lincolnshire, Illinois 60069 | 800.323.8185 | +1.847.537.8800 worldwide | +1.847.520.1147 fax

www.ehwachs.com

SPECIFICATIONS

Drive Options:

Pneumatic and Hydraulic
 Electric Drive Available by Special Order

Power Requirements:

Pneumatic: 50 cfm @ 85 psi (1.4m³/m @ 5.9 bar)
 Hydraulic: 10 gpm @ 1500 psi (38 lpm @ 106 bar)
 Hydraulic Goliath: 15 gpm @ 1500psi
 (57 lpm @ 106 bar)

Machine Capacity:

Cold cutting of pipe from 2" through 32"
 (DN50-800) plus conductors, structure and
 solids, varies by model

Installation Method: Standard cast iron
 V saddle and mounting chain, optional
 autoclamping on select models, custom
 mounting saddles for non circular shapes
 such as squares and I-beams



Wachs Goliath® saw shown horizontally
 severing multistrand conductor

GUILLOTINE SAW DIMENSIONS

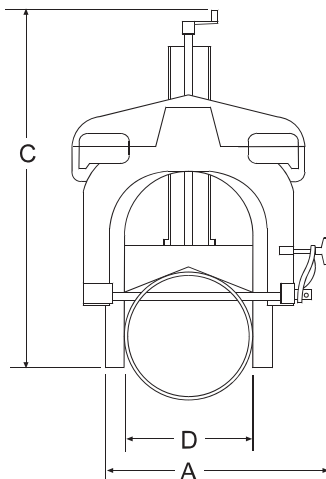
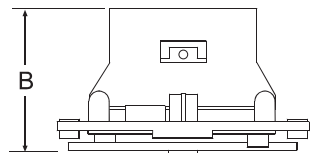

Controls: Single crank, manual feed.
 Motor on-off.

Lubrication: Grease fittings at all wear points.

Finish: Polished metal & Safety Yellow epoxy

STANDARD EQUIPMENT

- 1 saw blade
- 1 1/4" wrench
- Air lubricator and filter (Pneumatic)
- Steel storage case (Super C only)
- Lifting eyes
- Mounting chains

OPTIONAL EQUIPMENT

- General purpose & heavy duty blades
- Custom Mounting Saddles
- Autofeed
- Autoclamp with Rapid Retract
- Hydraulic Manifold
- Universal Control Panel (UCP 3)
- HPU Hydraulic Power Unit

WARRANTY

E.H. Wachs machine tools and their associated parts are warranted against defects in materials and workmanship for a period of twelve months from the date of purchase. E.H. Wachs expressly reserves the right to repair or replace only those parts which prove to have been defective at the time of purchase. This warranty becomes void if maximum flow and pressure ratings are exceeded.

CONTACT US FOR A DEMO OR QUOTE

E-mail: info@ehwachs.com

Telephone: +1.847.537.8800

Fax: +1.847.520.1147

Visit our website: ehwachs.com

Worldwide Headquarters

600 Knightsbridge Parkway
 Lincolnshire, Illinois 60069

	SUPER C	MODEL D	SUPER D	GOLIATH
Pipe Diameter	2"-12" (51mm-305mm)	6"-18" (152mm-457mm)	10"-24" (254mm - 610 mm)	16"-32" (406mm - 813mm)
Maximum Solid Thickness	12 3/4" (324 mm)	18 5/8" (473 mm)	24 1/2" (622 mm)	33" (838 mm)
Clearance Overall Width	28" (711 mm)	32" (813 mm)	39" (991 mm)	66" (1676 mm)
Clearance One side min	2 1/2" (63.5 mm)	3" (76 mm)	3" (76 mm)	Call
Operating Weight	115 lbs (51.75 kg)	340 lbs (153 kg)	515 lbs (232 kg)	1800 lbs (816 kg)
Shipping Weight	180 lbs (81 kg)	415 lbs (186.75 kg)	620 lbs (279 kg)	Call
Dimension A	23 1/2" (596.9 mm)	31 1/4" (793.7 mm)	38 1/4" (971.55 mm)	66" (1676 mm)
Dimension B	12 3/4" (323.85 mm)	14 1/2" (368 mm)	14 1/2" (368 mm)	25" (635 mm)
Dimension C	31 1/2" (800.1 mm)	37" (939.8 mm)	44" (1117.6 mm)	76.5" (1943 mm)
Dimension D	13 1/4" (336.55 mm)	18 3/4" (476.25 mm)	24 3/4" (628.65 mm)	33" (838 mm)
Stroke	2" (50.8 mm)	2" (50.8 mm)	4" (101.6 mm)	Call