



DESCRIPTION

Wachs SDB 412/2 is a hand held beveling machine that delivers maximum power and performance for fast, accurate O.D. weld preps on pipe and tube from 4" thru 12" (101 - 305mm) up to 1.125" (29mm) wall. The SDB 412 is designed to face, bevel and counterbore simultaneously on carbon, stainless and high alloy steels. A proven workhorse, it sets up quickly with a self centering mandrel and chuck assembly that mounts to the pipe I.D. The SDB 412's design means one person can set up, operate and create perfect weld preps in minutes.

VERSATILE DESIGN

Like the smaller SDB 103 and 206, the SDB 412 is highly versatile. It's ideal for machining thin wall pipe, heavy wall tube, prepping tees, elbows and valves and (with the optional FF kit) flange facing. Its compact design requires minimal operating clearance. The strong yet lightweight aluminum and hardened steel construction allows for ease of handling with fast setup and operation.

The optional FF Kit converts the SDB 412 to the FF 424 Flange Facer for facing raised and flat face flanges from 4" I.D. to 24" O.D. (102mm I.D. to 610mm O.D.) With the FF Kit your SDB 412 can be used for both end preps and flange facing, making it highly cost effective. Easy to set up, easy to operate and easy to get a perfect weld prep, Wachs SDB 412 is an easy choice in large diameter end prep machine tools.

RUGGED CONSTRUCTION

- Compact, heavy duty cast aluminum housing is tough yet lightweight
- Precision tapered roller bearings and self lubricating bushings maximize machine life
- Special heat treated ring and pinion gears for demanding pipe prepping applications
- High strength, large diameter mandrel shaft and wide surface chuck legs maximize rigidity
- Right angle air motor placement minimizes clearance requirements
- Corrosion and wear resistant finish applied to external components

FAST SETUP

- Quick change extension legs use captivated fasteners to mount firmly to mandrel
- One adjustment, expandable I.D. mount three leg chuck automatically centers and squares the machine
- Four tool rotating head with large tool locking set screws
- Install or adjust tool bits in seconds
- Only 2 hand tools required for setup, both included

EASY OPERATION

- Convenient on/off motor valve with adjustable hand grip speed control
- Infeed hand wheel with indices for precise measurement
- Adjustable Feed tension is user adjustable and absorbs torque and reduces operator fatigue
- Cast in heavy duty handle for easy transport and secure handling
- Set up square in elbows, tees, and valves with optional 3 leg fitting mandrel (included in FF Kit)
- SDB 412 quickly converts to FF 424 flange facer with optional FF Kit

**FACE
 BEVEL
 COUNTERBORE**



SDB 412 sets up quickly with self centering mandrel and quick change extension legs

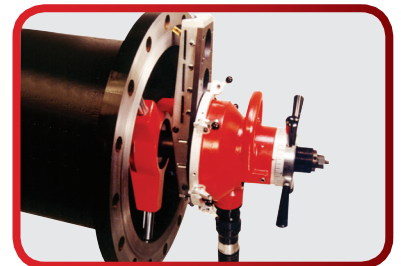

SDB 412 easily converts to a powerful flange facer with the optional FF kit



FF Kit allows flange facing, includes 3 leg mandrel for elbows, tees and valves

SPECIFICATIONS

Machine Function:

- Portable, onsite end prep machine to face, bevel, compound bevel, J-Prep and counterbore using up to 4 tools simultaneously
- Machine flat face and raised face flanges, record groove 500RMS, 250 RMS, 125 RMS and 63 RMS with optional flange facing kit
- Machine elbows, tees and valves with optional 3 leg fitting mandrel. Mandrel sold separately, included in optional FF Kit

Capacity: Mounts in 3.80" (97mm) I.D. through 12.75" (324mm) O.D. pipe

Machines:

- 4" (102mm) extra heavy duty through 8" (203mm) pipe up to 1.125" (29mm) wall thickness
- 10" (254 mm) pipe to schedule 160 1.125" (28.5 mm) wall thickness
- 12" (305 mm) pipe to schedule 120 1" (25.4 mm) wall thickness

Controls:

- Manual infeed with index gauge for precise measurement and feed
- On/Off Fail Safe Motor Lever
- Speed Control Valve (Pneumatic, Hydraulic Drive)

Axial Feed: .080" (2mm) per revolution, 3" (76mm) total travel

Mandrel: Self centering I.D. mounted single action 3 blade system with adjustable expansion nut. Complete set of 8 extension leg sets with captivated fasteners covers 3.80" (97mm) I.D. through 12.75" (324mm) O.D.

Drive: Pneumatic, Hydraulic and Electric 110V 60 Hz or 220V 50 Hz

Air Requirements: 55 CFM @ 90 PSI (1.553 l/min @ 6.2 BAR)

Hydraulic Requirements: 8 GPM @ 1,500 PSI (30.3 l/min @ 103.4 BAR)

Tool RPM: 0 to 30 RPM

Genuine Wachs Tooling:

- Single Point Tooling Holder and Inserts
- Single Point Flange Facing Tools (requires optional FF Kit)
- Form Tool Holder and Inserts for facing, beveling and J-Prep
- Counterbore Tooling, Holder and Inserts

Weight:

Basic machine without mandrel 51 lbs (23 kg), standard mandrel 17 lbs (8 kg)

STANDARD EQUIPMENT

Basic Machine and Drive Motor:

- Standard Machine and Complete Extension Leg Set
- 13.5" (342 mm) O.D. Rotating Machine Head
- Operating Hand Tools
- Owners Manual
- Storage Case

OPTIONAL ACCESSORIES

- Fitting Mandrel, 3 Leg Adjustable for Elbows, Tees, Valves and Flanges
- FF Kit for Flange Facing
- Thin Wall I.D. Mounting Kits for Schedule 5, Schedule 10
- ATM Air Treatment Module
- Low Clearance Tool Holder
- Dial Indicator System

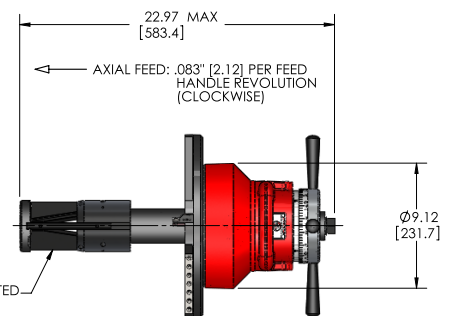
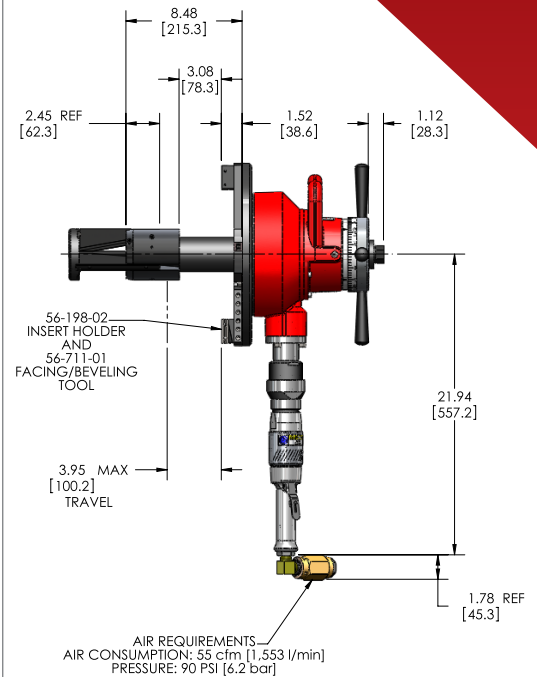

SDB MODEL	US PIPE SIZE	METRIC PIPE SIZE	POWER SOURCE
SDB 103/3	.875" ID to 4.5" OD	22.2mm ID to 114mm OD	Pneumatic, Electric
SDB 206/2	1.91" ID to 6.625" OD	48.5mm ID to 168mm OD	Pneumatic, Hydraulic, Electric
SDB 412/2	3.80" ID to 12.75" OD	96.5mm ID to 323.9mm OD	Pneumatic, Hydraulic, Electric