

ORBIWELD 12, ORBIWELD 19

**RENTAL
AVAILABILITY**

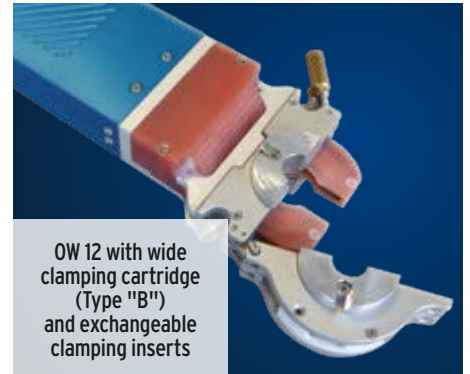

Optimal for high purity welding applications in confined spaces



OW 12 with wide clamping cartridge (Type "B") and exchangeable clamping inserts

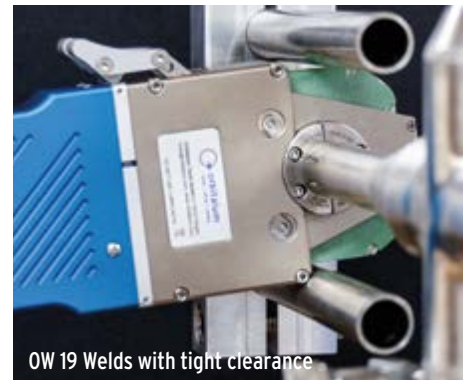

OW 19 Welds with tight clearance

MICRO WELD HEADS

EXTREMELY NARROW HIGHLY DURABLE DESIGN WITH INTEGRATED WATER COOLING SYSTEM: THE SMALL DIMENSIONS OF THE OW 12 AND OW 19 WELD HEADS MAKE THEM IDEAL FOR APPLICATIONS WHERE SPACE IS VERY RESTRICTED, SUCH AS THE SEMICONDUCTOR INDUSTRY, AEROSPACE, PHARMACEUTICAL INDUSTRY AS WELL AS THE ULTRA PURE WATER SUPPLY SECTORS. PARTICULARLY SUITABLE FOR WELDING ALL COMMON MICROFITTINGS.

ORBIWELD 12

- With its extremely compact design and different clamping cartridges, the OW 12 microweld head offers a unique versatility and a quick power-on time new for weld heads of this size due to the water coolant system
- Quick change system for clamping shells
- All the important commands for welding can be transmitted to the power supply via a control panel built into the robust and durable aluminum handle, so that no additional remote control is required

- Extremely narrow clamping cartridges (Type "A") for welding microfittings and for other applications with very limited clamping lengths
- Wide clamping cartridge (Type "B") with exchangeable clamping shells for standard applications
- The removable clamping cartridge enables accurate alignment with the parts to be welded, even where there is very little space

ORBIWELD 19

- The 3-part clamping mechanism ensures that the head can be clamped in the most confined spaces, as even when open no parts protrude beyond the contour of the head. Equally, an exact alignment, with no misalignment is guaranteed with the parts to be welded
- All the important commands for welding can be transmitted to the power supply via a control panel built into the robust and durable aluminum handle, so that no additional remote control is required

Possible applications OW 12:	Microfitting-to-microfitting	Microfitting-to-tube	Tube-to-tube	Advantages
Clamping cartridges, Type "A" (narrow)	•	•	•	High flexibility thanks to narrow design
Clamping cartridges, Type "B" (wide)			•	Low cost due to exchangeable clamping inserts

ORBIWELD 12, ORBIWELD 19 Micro Weld Heads

ORBIWELD Micro Weld Head Models

Clamping cartridges and clamping inserts are not included in the scope of delivery.

APPLICATION RANGE	ORBIWELD 12	ORBIWELD 19
Code	0T821.000.010	0T822.000.010
Tube OD, min. - max.	3.0 - 12.7 mm (0.118 in - 0.500 in)	3.0 - 19.05 mm (0.118 in - 0.750 in)
Electrode Ø	1.0 mm (0.039 in)	1.0 / 1.6 mm (0.039 in / 0.063 in)
Weight	5.7 kg (12.6 lbs)	7.5 kg (16.5 lbs)
Shipping Weight	11.0 kg	14.8 kg
Hose package length	7.5 m (24.6 ft)	7.5 m (24.6 ft)

SCOPE OF DELIVERY

Including:

- 1 Micro weld head
- 1 Durable storage and shipping case
- 1 Tool set
- 1 Operating instructions and spare parts list

Accessories (available option):

- Clamping cartridges for OW 12, Type "A" (narrow)
- Clamping cartridge for OW 12, Type "B" (wide)
- Clamping inserts for OW 12, Type "B" (wide)
- Clamping cartridges for OW 12, Type "C"
- Clamping inserts for OW 19
- ESG tungsten grinders
- ORBmax digital oxygen analyzer
- ORBIPURGE forming set
- Hose package extensions
- WS2 tungsten electrodes



OW 12 with narrow clamping cartridge (Type "A")



OW 12 with wide clamping cartridge (Type "B") and exchangeable clamping inserts



ORBIWELD 19

ORBIWELD 12 DIMENSIONS												
CARTRIDGE TYPE	A1	A2	B	C	D	E	F	G	H	I	J	K
	0.17in 4.25mm	0.15in 3.75mm	0.3in 7.62mm	2.87in 73mm	1.44in 36.5mm	1.08in 27.5mm	1.93in 49mm	9.96in 253mm	2.32in 59mm	1.02in 26mm	1.18in 30mm	2.32in 59mm
A	0.25in 6.35mm	0.23in 5.85mm	0.48in 12.2mm									
B	0.61in 15.6mm	0.59in 15.1mm	1.21in 30.7mm									
C	0.9in 22.79mm	0.86in 21.91mm	1.76in 44.7mm									

ORBIWELD 19 DIMENSIONS												
CARTRIDGE TYPE	A1	A2	B	C	D	E	F	G	H	I	J	K
	0.47in 12mm	0.47in 12mm	1.34in 34mm	2.6in 66mm	1.3in 33mm	1.39in 35.2mm	1.77in 45mm	12.28in 312mm	2.99in 76mm	1.34in 34mm	1.38in 35mm	2.8in 71mm
S	0.5in 12.8mm	0.46in 11.7mm	0.97in 24.5mm									
W	0.65in 16.5mm	0.69in 17.5mm	1.34in 34mm									

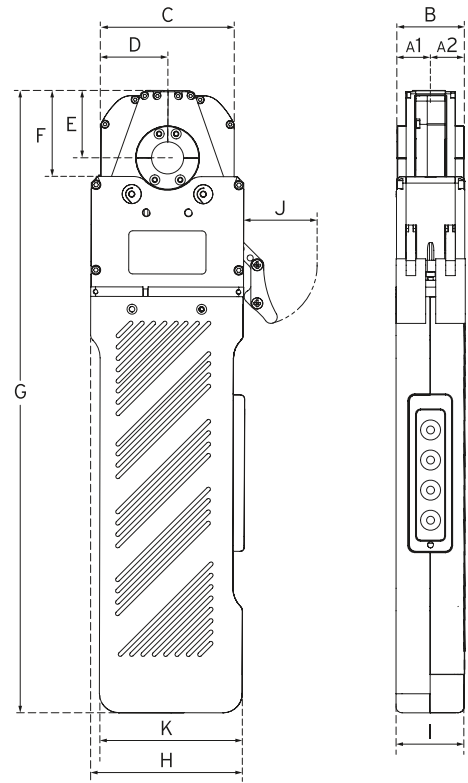

ORBIWELD 12, ORBIWELD 19 Accessories

Clamping cartridges for OW 12, Type "A" (narrow)

For type "A" a separate clamping cartridge is required for each tube diameter. Clamping cartridges with a total width of only 12.2 mm (0.48 in) can be supplied for welding of microfittings and other applications with very limited clamping lengths (Type "A").

MODEL	TUBE OD	WEIGHT	CODE
Stainless Steel clamping cartridge for OW 12, Type "A" (narrow)	.078in (2mm)	1.8 oz (50 g)	OT821.050.200
Stainless Steel clamping cartridge for OW 12, Type "A" (narrow)	.118in (3mm)	1.8 oz (50 g)	OT821.050.201
Stainless Steel clamping cartridge for OW 12, Type "A" (narrow)	.125in (3.18mm)	1.8 oz (50 g)	OT821.050.202
Stainless Steel clamping cartridge for OW 12, Type "A" (narrow)	.236in (6mm)	1.8 oz (50 g)	OT821.050.203
Stainless Steel clamping cartridge for OW 12, Type "A" (narrow)	.250in (6.35mm)	1.7 oz (48 g)	OT821.050.204
Stainless Steel clamping cartridge for OW 12, Type "A" (narrow)	.314in (8mm)	1.7 oz (48 g)	OT821.050.205
Stainless Steel clamping cartridge for OW 12, Type "A" (narrow)	.375in (9.53mm)	1.7 oz (48 g)	OT821.050.206
Stainless Steel clamping cartridge for OW 12, Type "A" (narrow)	.394in (10mm)	1.7 oz (48 g)	OT821.050.207
Stainless Steel clamping cartridge for OW 12, Type "A" (narrow)	.472in (12mm)	1.7 oz (48 g)	OT821.050.208
Stainless Steel clamping cartridge for OW 12, Type "A" (narrow)	.500in (12.7mm)	1.6 oz (45 g)	OT821.050.209



Clamping cartridges for OW 12, Type "A" (narrow)

Clamping cartridge for OW 12, Type "B" (wide)

When using the exchangeable clamping cartridges, Type "B", one set of clamping inserts is required in addition for each tube diameter.

MODEL	WEIGHT	CODE
Clamping cartridge for OW 12, Type "B" (wide)	3.4 oz (95 g)	OT821.050.002



Clamping cartridge for OW 12, Type "B" (wide)

Clamping inserts for OW 12, Type "B" (wide)

Aluminum, these inserts require Type "B" clamping cartridges. One clamping insert set includes 4 individual parts (2 inserts each side).

MODEL	TUBE OD	WEIGHT	CODE
Collet insert set for OW 12, Type "B" (wide), 4 pcs.	.118in (3mm)	1.9 oz (54 g)	OT821.002.220
Collet insert set for OW 12, Type "B" (wide), 4 pcs.	.125in (3.18mm)	1.9 oz (54 g)	OT821.002.222
Collet insert set for OW 12, Type "B" (wide), 4 pcs.	.187in (4.76mm)	1.9 oz (54 g)	OT821.002.225
Collet insert set for OW 12, Type "B" (wide), 4 pcs.	.236in (6mm)	1.8 oz (50 g)	OT821.002.228
Collet insert set for OW 12, Type "B" (wide), 4 pcs.	.250in (6.35mm)	1.8 oz (50 g)	OT821.002.229
Collet insert set for OW 12, Type "B" (wide), 4 pcs.	.314in (8mm)	1.8 oz (50 g)	OT821.002.233
Collet insert set for OW 12, Type "B" (wide), 4 pcs.	.375in (9.53mm)	1.8 oz (50 g)	OT821.002.235
Collet insert set for OW 12, Type "B" (wide), 4 pcs.	.394in (10mm)	1.7 oz (48 g)	OT821.002.237
Collet insert set for OW 12, Type "B" (wide), 4 pcs.	.472in (12mm)	1.7 oz (48 g)	OT821.002.243
Collet insert set for OW 12, Type "B" (wide), 4 pcs.	.500in (12.7mm)	1.7 oz (48 g)	OT821.002.245



Clamping inserts for OW 12, Type "B" (wide), 4 pcs.

Clamping inserts for OW 19

Stainless steel, one clamping insert set includes 6 individual parts (3 inserts each side). Type "W" (wide) for standard applications.

MODEL	TUBE OD	WEIGHT	CODE
Collet insert set for OW 19, 6 pcs. Type "W" (wide)	.118in (3mm)	1.6 oz (44 g)	OT822.002.120
Collet insert set for OW 19, 6 pcs. Type "W" (wide)	.125in (3.18mm)	1.6 oz (44 g)	OT822.002.122
Collet insert set for OW 19, 6 pcs. Type "W" (wide)	.187in (4.76mm)	1.6 oz (44 g)	OT822.002.125
Collet insert set for OW 19, 6 pcs. Type "W" (wide)	.236in (6mm)	1.6 oz (44 g)	OT822.002.128
Collet insert set for OW 19, 6 pcs. Type "W" (wide)	.250in (6.35mm)	1.5 oz (42 g)	OT822.002.129
Collet insert set for OW 19, 6 pcs. Type "W" (wide)	.314in (8mm)	1.5 oz (42 g)	OT822.002.132
Collet insert set for OW 19, 6 pcs. Type "W" (wide)	.375in (9.53mm)	1.4 oz (40 g)	OT822.002.135
Collet insert set for OW 19, 6 pcs. Type "W" (wide)	.394in (10mm)	1.4 oz (40 g)	OT822.002.137
Collet insert set for OW 19, 6 pcs. Type "W" (wide)	.472in (12mm)	1.2 oz (35 g)	OT822.002.143
Collet insert set for OW 19, 6 pcs. Type "W" (wide)	.500in (12.7mm)	1.2 oz (35 g)	OT822.002.145
Collet insert set for OW 19, 6 pcs. Type "W" (wide)	.625in (15.88mm)	1.2 oz (35 g)	OT822.002.157
Collet insert set for OW 19, 6 pcs. Type "W" (wide)	.750in (19.05mm)	1.0 oz (30 g)	OT822.002.166



Clamping insert for OW 19 "W" (wide) 6 pcs.