



PART NUMBER

14-000-35

RENTAL
AVAILABILITY



Standard remote control pendant includes flow direction, pump speed and E-stop.

DESCRIPTION

E.H. Wachs HPU-20 is a portable, electric motor driven hydraulic power unit that replaces Wachs HPU-15. Standard with remote control, it utilizes a compact vertical design that is more powerful and affords greater flow than the previous unit. Powered by a 20HP 380-480V 3 phase electric motor, it's the superior choice for power plants, fabrication shops and contractor sites where a long lasting, smooth, continuous power source is needed to run hydraulic equipment in a production environment. For specialized applications a glycol version HPU-20GY is available by special order. A CE complaint unit is also available, ask your Wachs representative for additional details.

QUIET OPERATION

The HPU-20 features an advanced pump and motor assembly that's submerged in the hydraulic oil reservoir to save space, run quieter and cool the motor for longer life. The pump features helical cut gears for superior performance. The heavy

duty steel frame is powder coated for corrosion resistance and includes forklift pockets, built in lifting points and a detachable, removable wheeled cart with non-marring casters for mobility.

REMOTE CONTROL

The included remote control pendant includes a 12 ft (3.7m) cable with a 50 ft (15.2m) extension, with optional longer lengths up to 150 ft (45.7m) available. The pendant includes remote stop / start, e-stop, flow direction and pump speed. The HPU-20 features variable flow from 4 to 18 GPM (15-68 l/min) with an 1800 psi (124 BAR) pressure setting.

COMPACT DESIGN

The HPU-20's vertical design allows for a more compact footprint, making it easier to transport, store and operate in tight quarters. All the electronics are located above the oil reservoir for space savings, and away from any potential contamination. Placing the pump assembly inside the oil reservoir contributes to its compact design.



Innovative design submerges pump in oil reservoir for cooler, quieter operation.

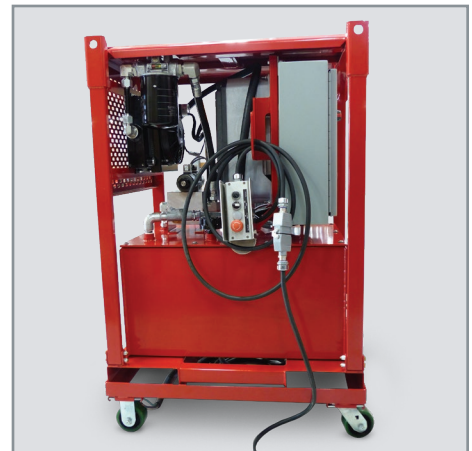

Steel cabinets are designed to protect power and control circuitry from damage.



Large hydraulic oil reservoir with temperature and level gauge plus warning light.



STANDARD FEATURES

- UL Listed NEMA 4 Electrical Controls Power (50/60HZ 3 Phase)
- 380-480V 3 phase input power*
- Low oil / over temp warning light
- Remote pendant control with a 12 ft and a 50 ft extension cable
- Remote stop / start and flow control
- Removable base with non-marring urethane casters
- Five (5) point rigging / lifting system
- Heat exchanger complete with digital readout
- Ultra quiet helical hydraulic gear pump
- Powder coat finish
- Operating manual

OPTIONS

- Hydraulic oil tank heater for cold weather operation
- Remote pendant control extension cables
- Hydraulic hose sets and disconnects

SPECIFICATIONS

- Dimensions (with base): 34.75in L x 52.5in H x 26in W (88cm x 133cm x 66cm)
- Motor: 20HP/15kW 3 phase electric motor *
- Electric Power Requirements: 380-480V (3 Phase) 50/60Hz @ 30 Amps
- Input voltage limit: 380-460V, +/- 15% (325-530v)
- Hydraulics: 30 gal (114 liters) AW 32 (preferred) or AW 46 oil capacity**
- Filtration: 10 micron hydraulic oil filtration
- Factory Pressure Relief Setting: 1800 psi (124 BAR)
- Variable Flow: 4-18 GPM (15-68 l/min at 124 BAR)
- Weight: 850 lb (386 kg), including oil and mobile base **
- Sound level: 62db at full flow and operation
- Operating Temperature: 110° F (43° C)

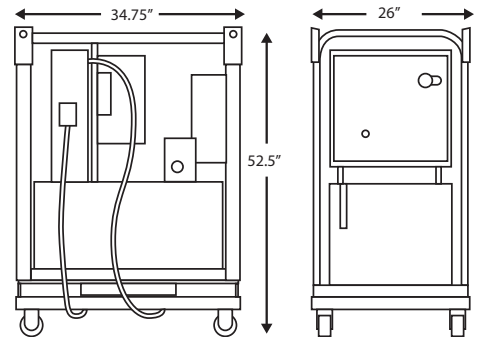

Spin on full flow hydraulic oil filter helps extend oil and pump life.



Heavy duty cooling and hydraulic manifold help keep fluid temperatures down.



HPU-20GY model with water based glycol in place of hydraulic oil is also available.

**DRIVE MOTOR TORQUE COMPARISON
ELECTRIC, PNEUMATIC & HYDRAULIC DRIVE**

