



# **TRAV-L-CUTTER**

## **MODEL E & H/E**

### **STANDARD & ATMOSPHERIC**

#### **02-000-01,-02,-03,-04**

E.H. Wachs  
600 Knightsbridge Parkway  
Lincolnshire, IL 60069  
www.ehwachs.com

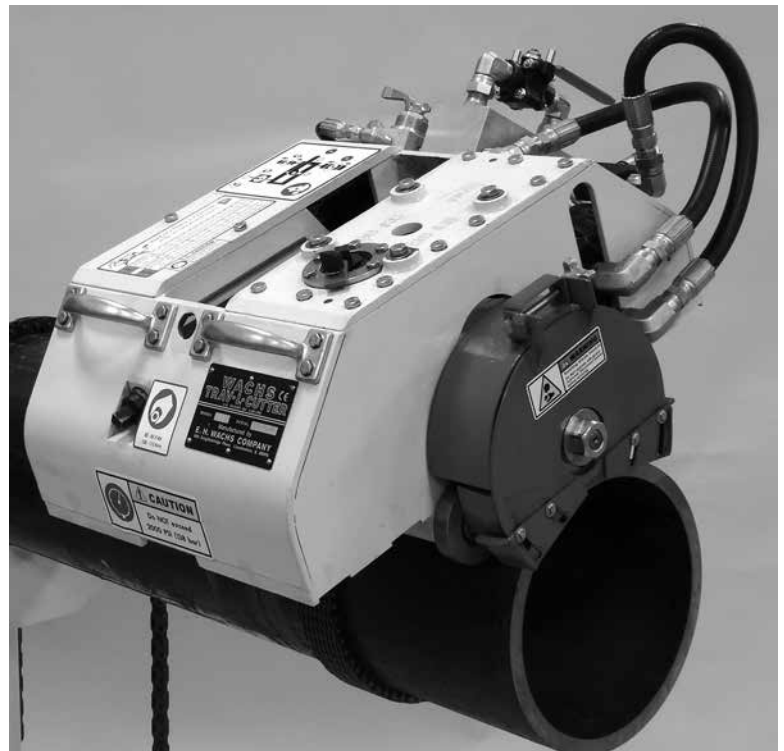

E.H. Wachs Part No. 02-MAN-01  
Rev. A, March 2014

Copyright © 2014 E.H. Wachs. All rights reserved.  
This manual may not be reproduced in whole or in part  
without the written consent of E.H. Wachs.

**EU DECLARATION OF CONFORMITY  
WITH  
COUNCIL DIRECTIVE 2006/42/EC**

<b>Issue Details:</b>	DATE: 1/1/2011	Place: E.H.Wachs, Lincolnshire, IL USA
<b>Directives:</b>	Machinery Safety Directive 2006/42/EC	
<b>Conforming Machinery:</b>	<u>Trav-L-Cutter:</u>	
<b>Model Number:</b>	02-000-01, 02-000-02	
<b>Serial Number:</b>		
<b>Manufacturer:</b>	<b>E.H. Wachs</b> 600 Knightsbridge Parkway Lincolnshire IL 60069 USA	
<b>Responsible Representative:</b>	Orbitalum Tools GmbH Josef-Schüttler-Str. 17, 78224 Singen Germany Tel. +49 (0) 7731 - 792 872 Fax +49 (0) 7731 - 792 566	
<b>Harmonised Standards &amp; Other Technical Standards/Specifications Applied or Referenced:</b>	EN ISO 12100-1:2003 + A1:2009 EN ISO 12100-2:2003 + A1:2009 EN 60201-1:2006 (for electric machines) EN ISO 13857:2008 EN 982:1996 + A1:2008 (E) (for hydraulic machines) EN 983:1996 (for pneumatic machines) EN 13732-1:2006 EN ISO 14121-1:2007 EN ISO 13850:2008 (for pneumatic machines)	
<b>Provisions with which Conformity is Declared:</b>	Essential Health and Safety Requirements of Annex 1 of the Machinery Directive	
<b>We hereby certify that the machinery described above conforms to the provisions of Council Directive 2006/42/EC on the approximation of the laws of the Member States relating to the safety of machinery.</b>		
<b>Signed:</b>		
<b>Signatory:</b>	Pete Mullally Quality Manager E.H. Wachs	

# Table of Contents

<b>Chapter 1: Introduction to the Equipment</b> .....	<b>1</b>
Purpose of This Manual .....	1
How to Use The Manual .....	1
Symbols and Warnings .....	2
Manual Updates and Revision Tracking .....	3
Equipment Description .....	3
Compact Design, Easy Set-up .....	3
Standard Weld Prep Capability .....	3
Grooved, Mechanical Joint Preparation .....	3
Offshore or Pipe Line Maintenance .....	3
Corrosion Resistant .....	4
Operates Anywhere .....	4
Safe, Cold Cutting .....	4
Fast, Reliable .....	4
 <b>Chapter 2: Safety</b> .....	 <b>5</b>
Safe Operating Guidelines .....	5
Safe Operating Environment .....	6
Operating and Maintenance Safety .....	6
Safety Alerts in This Manual .....	6
Protective Equipment Requirements .....	7
Protective Clothing .....	7
Eye Protection .....	7
Hearing Protection .....	7
 <b>Chapter 3: Machine Specifications</b> .....	 <b>9</b>
 <b>Chapter 4: Setup and Operating Procedures</b> .....	 <b>15</b>
Wheel Settings .....	15
Chain Lengths .....	16
Wheel Settings and Chain Length .....	17
Chain Length Calculations .....	17
Machine Installation .....	18
Operating the Machine .....	20
Special Instructions for Assembling 2” Wide Drive Chain .....	21
Operating Hints .....	22
 <b>Chapter 5: Maintenance</b> .....	 <b>23</b>
Lubrication Instructions .....	23

**Chapter 6: Consumable Select Chart** ..... 25  
Data on Cutter Size ..... 25  
Cutters ..... 27

**Chapter 7: Troubleshooting Problems**..... 29

**Chapter 8: Parts Lists & Exploded View Drawings** ..... 31

## Chapter 1

# Introduction to the Equipment

---

### **PURPOSE OF THIS MANUAL**

This manual explains how to operate and maintain the Trav-L-Cutter. It includes instructions for set-up, operation, and maintenance. It also contains parts lists and diagrams, and troubleshooting instructions to help you order replacement parts and perform user-serviceable repairs.

---

### **HOW TO USE THE MANUAL**

This manual is organized to help you quickly find the information you need. Each chapter describes a specific topic on using or maintaining your equipment.

Use these instructions to operate and maintain the equipment.

---

## SYMBOLS AND WARNINGS

The following symbols are used throughout this manual to indicate special notes and warnings. They appear in the outside column of the page, next to the section they refer to. Make sure you understand what each symbol means, and follow all instructions for cautions and warnings.



This is the **safety alert symbol**. It is used to alert you to **potential personal injury hazards**. Obey all safety messages that follow this symbol to avoid possible injury or death.



### WARNING

A WARNING alert with the safety alert symbol indicates a potentially hazardous situation that **could** result in **serious injury or death**.



### CAUTION

A CAUTION alert with the safety alert symbol indicates a potentially hazardous situation that **could** result in **minor or moderate injury**.



A CAUTION alert with the damage alert symbol indicates a situation that will result in **damage to the equipment**.



This is the **equipment damage alert symbol**. It is used to alert you to **potential equipment damage situations**. Obey all messages that follow this symbol to avoid damaging the equipment or workpiece on which it is operating.



### IMPORTANT

An IMPORTANT alert with the damage alert symbol indicates a situation that **may** result in **damage to the equipment**.



### NOTE

This symbol indicates a user note. **Notes** provide additional information to supplement the instructions, or tips for easier operation.

---

## **MANUAL UPDATES AND REVISION TRACKING**

Occasionally, we will update manuals with improved operation or maintenance procedures, or with corrections if necessary. When a manual is revised, we will update the revision history on the title page.

*Current versions of E.H. Wachs Company manuals are also available in PDF format. You can request an electronic copy of this manual by emailing customer service at [sales@ehwachs.com](mailto:sales@ehwachs.com).*

You may have factory service or upgrades performed on the equipment. If this service changes any technical data or operation and maintenance procedures, we will include a revised manual when we return the equipment to you.

---

## **EQUIPMENT DESCRIPTION**

### **Compact Design, Easy Set-up**

Lightweight, low profile design needs only 10” to 12” of clearance and set up time is ten minutes or less. Once the adjustable drive chain is pinned together and tensioned around the pipe the machine is ready to operate.

### **Standard Weld Prep Capability**

Weld preparation detail can be achieved from common 30° and 37-1/2° bevel on standard wall carbon steel.

### **Grooved, Mechanical Joint Preparation**

The Trav-L-Cutter can simultaneously cut off and groove pipe in one cut. Cutters are available for Victaulic and other grooved coupling systems.

### **Offshore or Pipe Line Maintenance**

The Wachs Hydraulic Trav-L-Cutter offers the inherent advantages of a completely sealed and self-lubricating closed loop system. The Model HE is particularly suited to field machining operations under the type of hostile conditions often found in pipe line maintenance and construction such as dirt, sand and water. It is a portable pipe cutting machine that can be used conveniently on offshore drilling rigs, pipe lines and on construction work in rivers and harbors.

### **Corrosion Resistant**

Corrosion from constant exposure to salt water can be minimized with an accessory package that includes extensive use of stainless steel fasteners, special bearings and seals and high zinc coating.

### **Operates Anywhere**

With air or hydraulic power, the Trav-L-Cutter will operate on horizontal or vertical pipe, in the field or in the shop. It cuts and bevels in a mud filled ditch or under water, where it has been used in chambers and free diving to depths of 600 feet.

### **Safe, Cold Cutting**

The Trav-L-Cutter can be used in explosive conditions, on natural gas, crude, product and fuel lines. It has even been used to cut missile fuel cells.

### **Fast, Reliable**

A standard wall pipe can be cut and beveled with a cutting speed of approximately 2 minutes per 1" of pipe diameter. Cutting time varies for heavier walls and harder alloys. Due to its rugged construction, it is not unusual to find machines still operating after 10 or 20 years of severe service.

### **Included with your TRAV-L-CUTTER:**

- Operating Manual and Isometric Parts List, Operating Tools, and spare Chain Connecting Pins.
- Basic Mounting Chain for 6" dia. pipe
- Steel Storage Case
- 6-ft. Hose Whip with oiler (air only)



## Chapter 2

# Safety

E.H. Wachs takes great pride in designing and manufacturing safe, high-quality products. We make user safety a top priority in the design of all our products.

Read this chapter carefully before operating the bridge slide. It contains important safety instructions and recommendations.

**FULL SAFETY INSTRUCTIONS AND GUIDELINES ARE IN THE MANUAL FOR YOUR TRAV-L-CUTTER MACHINE.** Make sure you read and understand these safety recommendations and operating instructions before operating.

---

### SAFE OPERATING GUIDELINES

Follow these guidelines for safe operation of all E.H. Wachs equipment.



Look for this symbol throughout the manual. It indicates a personal injury hazard.

- **READ THE OPERATING MANUAL.** Make sure you understand all setup and operating instructions before you begin. Keep this manual with the machine.
- **INSPECT MACHINE AND ACCESSORIES BEFORE USE.** Before starting the machine, look for loose bolts or nuts, leaking lubricant, rusted components, and any other physical conditions that may affect operation. Properly maintaining the machine can greatly decrease the chances for injury.
- **ALWAYS READ STICKERS AND LABELS.** Make sure all labels and stickers are in place, clearly legible, and in good condition. Refer to “Safety Labels” later in this chapter for label locations on the machine. Replace any damaged or missing safety labels; see the ordering information at the end of this manual.
- **KEEP CLEAR OF MOVING PARTS.** Keep hands, arms, and fingers clear of all rotating or moving parts. Always turn the machine off and disconnect the power source before doing any adjustments or service.

- **SECURE LOOSE CLOTHING AND JEWELRY.** Secure or remove loose-fitting clothing and jewelry, and securely bind long hair, to prevent them from getting caught in moving parts of the machine.
- **FOLLOW SAFE PROCEDURES FOR HANDLING LUBRICANTS.** Refer to the manufacturer’s instructions and the Material Safety Data Sheets.

### Safe Operating Environment

- Do not use this equipment in a potentially explosive atmosphere. Fire or explosion could result, with the risk of serious injury or death.
- Provide adequate lighting to use the equipment, in accordance with worksite or local regulations.
- **KEEP WORK AREA CLEAR.** Keep all clutter and nonessential materials out of the work area. Only people directly involved with the work being performed should have access to the area.

### Operating and Maintenance Safety

- This equipment is to be operated and maintained only by qualified, trained personnel.
- Make sure the equipment is stable when attached to the workpiece for the operation. Ensuring stability of the installed tool is the responsibility of the operator.
- Make sure the workpiece is supported adequately for installation of the equipment. This includes supporting any workpiece “fall-off” section when severing the workpiece. Ensuring support of the workpiece is the responsibility of the operator.
- Tooling on any cutting equipment—including lathe tools, saw blades, milling tools, etc.—may get very hot. Do not touch tooling until you have made sure it is cool enough to handle.
- Wear gloves when removing or cleaning up chips and cutting debris. Chips can be very sharp and cause cuts.
- Before performing any service on the equipment, disconnect the power source. Follow all lock-out/tag-out procedures required at the worksite.

### Safety Alerts in This Manual

The following alerts are used throughout this manual to indicate operator safety hazards. In all cases, these alerts include a notice describing the hazard and the means to avoid or reduce risk. Carefully read all safety alerts.



This icon is displayed with any safety alert that indicates a personal injury hazard.



## WARNING

This safety alert, with the personal injury hazard symbol, indicates a potentially hazardous situation that, if not avoided, **could** result in **death or serious injury**.



## CAUTION

This safety alert, with the personal injury hazard symbol, indicates a potentially hazardous situation that, if not avoided, **could** result in **minor or moderate injury**.

### **Protective Equipment Requirements**

#### **Protective Clothing**

**Wear safety shoes** when operating or servicing the equipment. Serious injury could result from dropping the machine or its components.

**Do not wear gloves** while operating the machine. Gloves can become entangled in moving parts, resulting in serious injury. Gloves may be worn when setting up the machine or cleaning up after the operation, but take them off when operating the machine.



## NOTE

Gloves should be worn when cleaning up chips and other cutting debris. Chips can be very sharp and can cause serious cuts. **Do not wear gloves when the machine is operating.**

#### **Eye Protection**

Always wear impact-resistant eye protection while operating or working near this equipment.

For additional information on eye and face protection, refer to Federal OSHA regulations, 29 Code of Federal Regulations, Section 1910.133., Eye and Face Protection and American National Standards Institute, ANSI Z87.1, Occupational and Educational Eye and Face Protection.

#### **Hearing Protection**

This equipment can produce noise levels above 80 dB. Hearing protection is required when operating the equipment. The operation of other tools and equipment in the area, reflective surfaces, process noises, and resonant structures can increase the noise level in the area.

For additional information on hearing protection, refer to Federal OSHA regulations, 29 Code of Federal Regulations, Section 1910.95, Occupational Noise Exposure and ANSI S12.6 Hearing Protectors.



## Chapter 3

# Machine Specifications

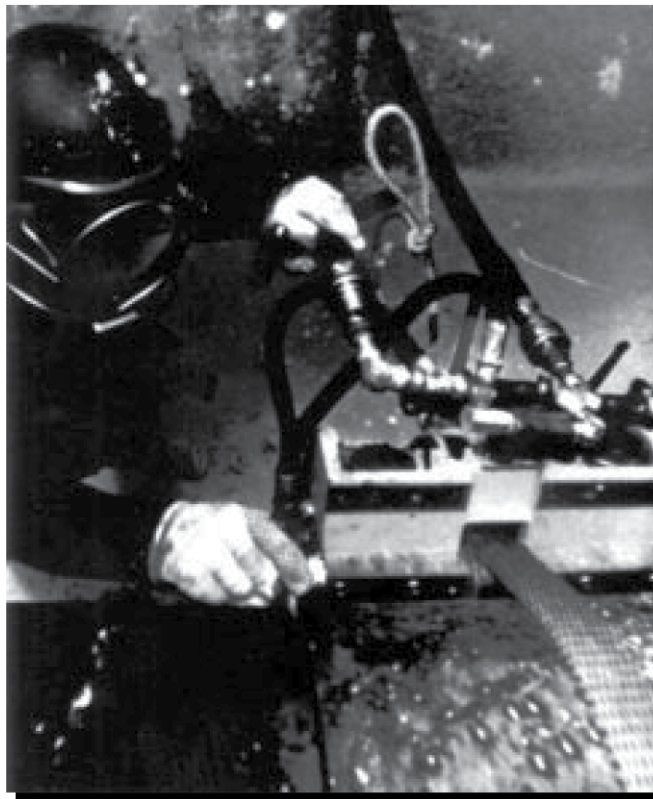

**Capacity:**

6" through 72" (153 to 1829 mm) pipe, large diameter vessels. All schedules.

**Cutter Drive:**

Pneumatic: 4 H.P. Governed Air Motor coupled with worm gearbox

**Hydraulic:**

As above, with hydraulic motor.

**Cutter Speed:**

Pneumatic: 55 R.P.M. Internally adjustable from 35 to 55 R.P.M. for use on alloys that might become work hardened. Hydraulic; Adjustable 0-60 R.P.M.

**Feed:**

Pneumatic: 3/4 H.P. Air Motor coupled through overload clutch, gearbox and chain reduction to final machine drive sprocket. Hydraulic: 4 H.P. Hydraulic Motor.

**Feed Method:** Positive, non-slip chain drive

**Air Requirements:** 100 cfm @ 90 psi (2,832 l/min @ 6.3 bar)

**Hydraulic Requirements:** 15 gpm @ 1500 psi. (57 l/min @ 106 bar)

**Clearance:**

10" to 12" (254 to 305 mm) radial, depending on pipe diameter. 20" axial (508 mm)

**Weight:**

Operating - 215 lbs. (97.7 kgs)

Shipping-(typical) - 418 lbs. (190 kg)

**Dimensions:**

Length: 24" (61 cm)

Width: 20" (51 cm)

Height: 10-3/4" (28 cm)

**Controls:**

(Pneumatic and Hydraulic):

Cutter on-off, feed on-off, with interlock to prevent machine feed unless cutter is turning. Adjustable Feed Speed Control (Hydraulic Only) Flow Control Valves. Separate controls provide adjustable feed and cutter speed. Forward/Reverse Valve. Permits machine to be backed up.

**Shipping and Storage Case:**

41" x 25" x 18" (104 x 63.5 x 45.7 cm)

10.7 cu. ft. (0.53 m<sup>2</sup>)

**Finish:** Paint

**Hose Assemblies (Hydraulic):**

5/8" hose sets with quick couplers, in 45' lengths

**Hydraulic Power Sources (Model HE):**

- Electric, Gasoline or Diesel Engine driven.

Gang of Cutters for Beveling Pipe

1 R.H. Bevel, 1 Slitting Saw, and 1 L.H. Bevel

DIMENSIONS IN BRACKETS ARE MILLIMETERS

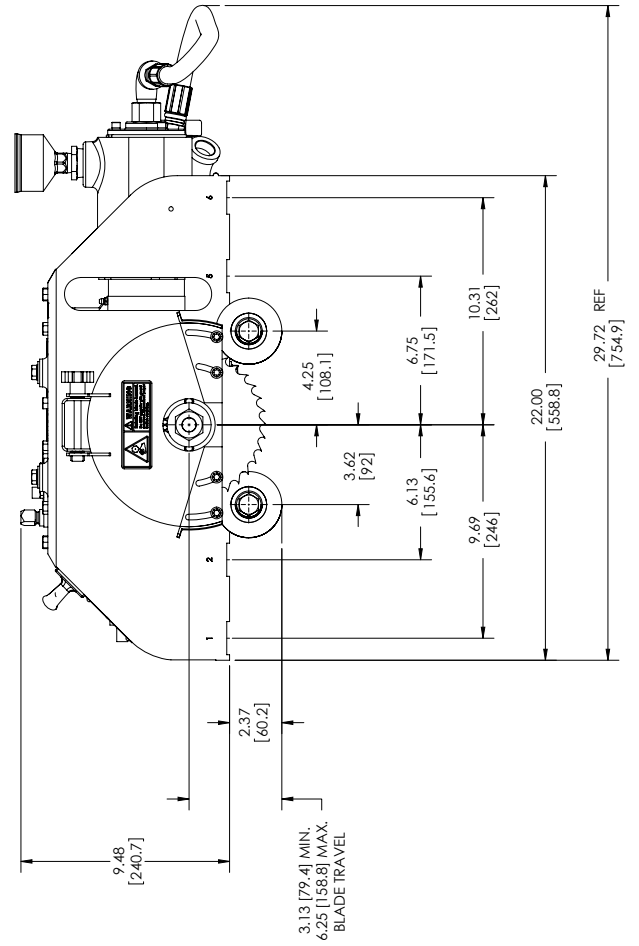
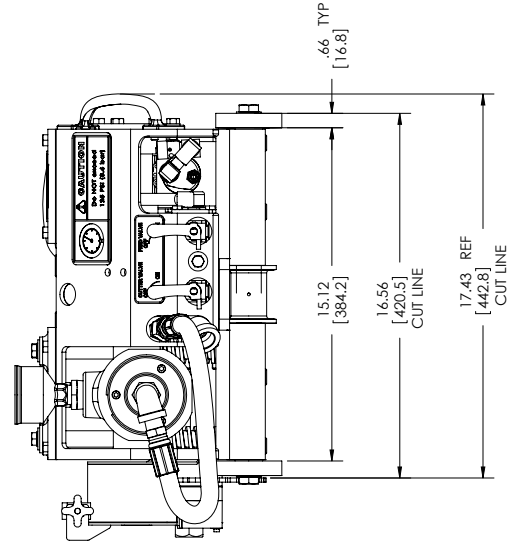
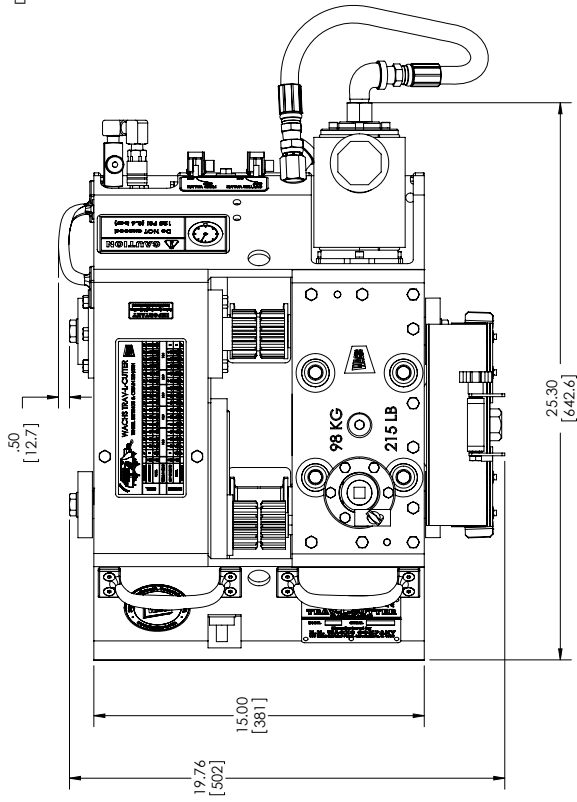
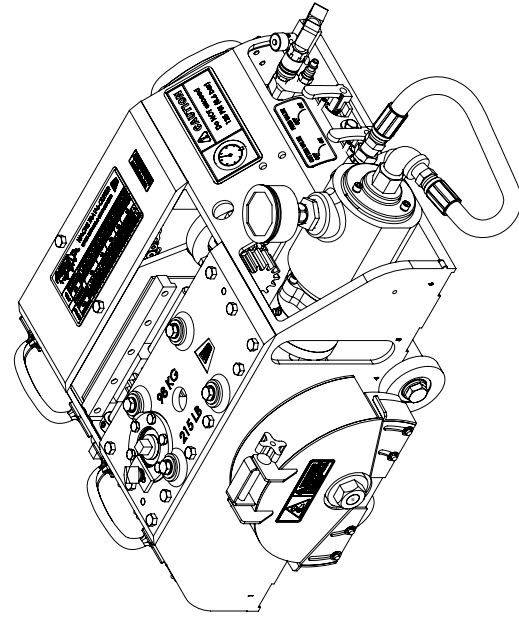

Operating Envelope  
 Trav-L-Cutter Assembly, Air Drive  
 02-000-01

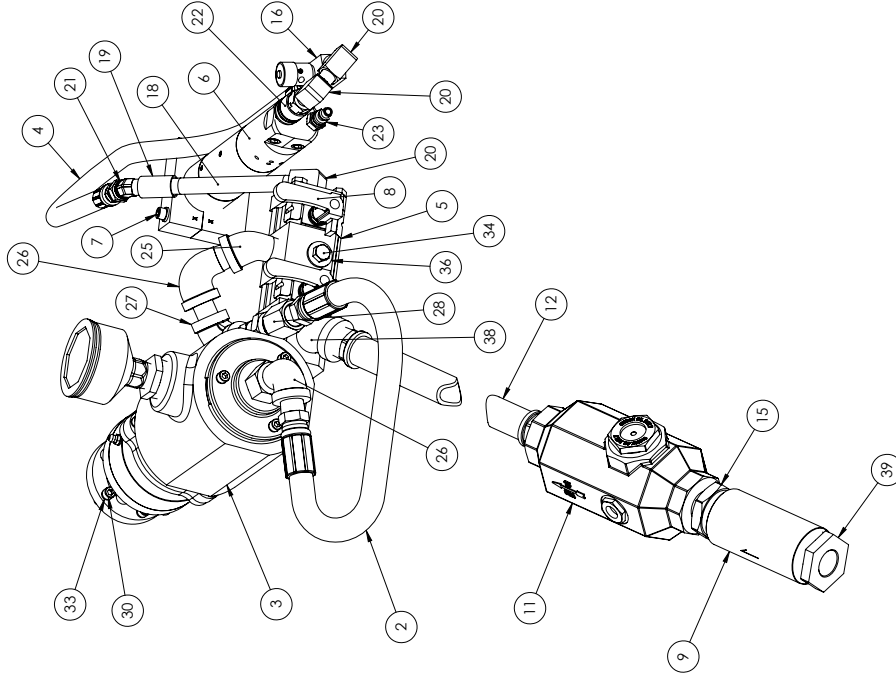

**TRAV-L-CUTTER  
AIR SYSTEM COMPONENTS**  
INPUT REQUIREMENTS  
1.25 PSI [8.6 bar] MAX.  
9.5 CFM [2690 l/min.]

ITEM	PART NUMBER	QTY.	DESCRIPTION
1	02-010-00	1	LABEL, PRESSURE-AIR (NOT SHOWN)
2	02-027-01	1	HOSE, 1/2" HP X 30" LONG
3	02-029-00	1	AIR MOTOR SUB-ASSEMBLY
4	02-031-00	1	HOSE, TRAVEL MOTOR
5	02-033-00	1	MANIFOLD, AIR
6	02-035-00	1	MOTOR, TRAVEL-AIR
7	02-037-00	1	CLAMP, AIR MOTOR
8	02-124-00	2	HANDLE, AIR VALVE
9	02-163-00	1	BODY, AIR FILTER
10	02-164-00	1	FILTER ELEMENT (NOT SHOWN)
11	02-166-00	1	AIR LINE LUBRICATOR
12	02-171-00	1	INLET AIR HOSE WHIP, 3/4" X 2"
13	02-185-00	1	LABEL, ON-OFF (NOT SHOWN)
14	02-191-00	1	SHIM, GEAR BOX (NOT SHOWN)
15	02-192-00	1	END PLUG
16	02-212-00	1	FLOW CONTROL VALVE 1/4"
17	90-044-53	4	SSS, 1.0-32 X 5/16 CP (NOT SHOWN)
18	90-058-02	1	NIPPLE, 1/4 X 5 GALV LP
19	90-058-04	1	COUPLING, 1/4 GALV LP
20	90-058-05	3	1/4 NPT F X 1/4 NPT M BRASS LP-90
21	90-058-51	1	ADAPTER, 1/4 NPT M X 1/4 NPT F SWIVEL-45
22	90-059-51	1	DISCONNECT, FEMALE 1/4 NPT M
23	90-059-53	2	DISCONNECT, MALE 1/4 NPT M
24	90-098-01	1	NIPPLE, 1/2 CLOSE LP BLACK (NOT SHOWN)
25	90-098-04	1	ELBOW, 1/2-45 STREET
26	90-098-05	1	ELBOW, 1/2-90 STREET
27	90-098-06	1	ELBOW, 1/2-90 LP
28	90-098-57	1	ADAPTER, 1/2 NPT F X 1/2 NPT F SWIVEL-STRAIGHT
29	90-098-58	1	1/2 HEX HP NIPPLE (NOT SHOWN)
30	90-150-08	5	SHCS, 1/4-20 X 7/8 SS18-8
31	90-153-10	4	FHCS, 1/4-20 X 1 SS18-8 (NOT SHOWN)
32	90-154-07	2	SSS, 1/4-20 X 3/4 SS18-8 (NOT SHOWN)
33	90-155-51	5	WASHER, 1/4" HI COLLAR SS18-8
34	90-161-07	1	FHCS, 5/16-18 X 5/8 SS18-8
35	90-161-10	2	FHCS, 5/16-18 X 1 SS18-8 (NOT SHOWN)
36	90-165-52	1	WASHER, 5/16 FLAT SS18-8
37	90-218-01	1	NIPPLE, 3/4 CLOSE LP (NOT SHOWN)
38	90-218-03	1	ELBOW, 3/4-45 LP STREET
39	90-218-10	1	BUSHING, 1-1/4 X 3/4 GLV REDUCING

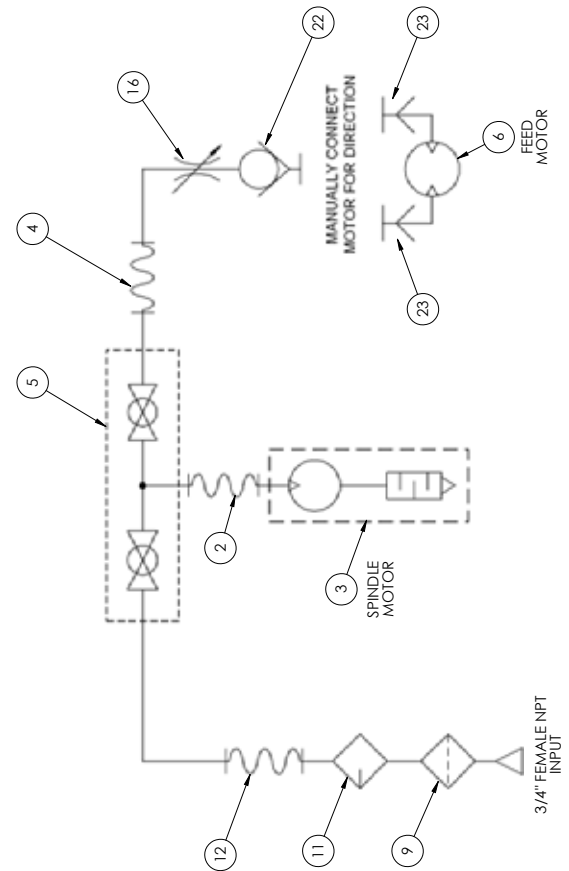



DIMENSIONS IN BRACKETS  
ARE MILLIMETERS

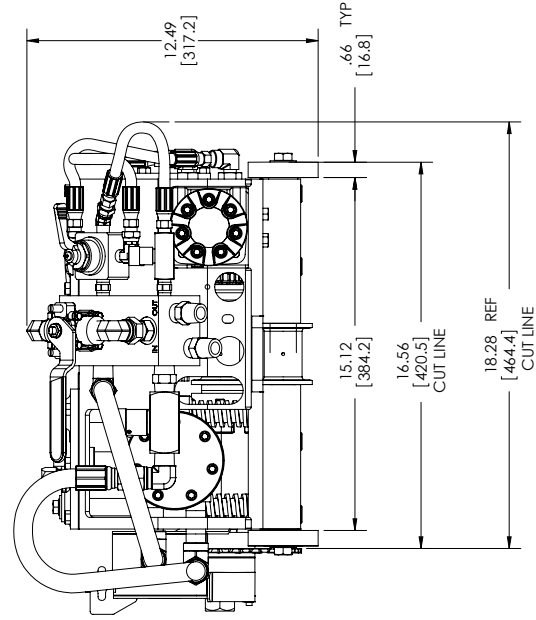
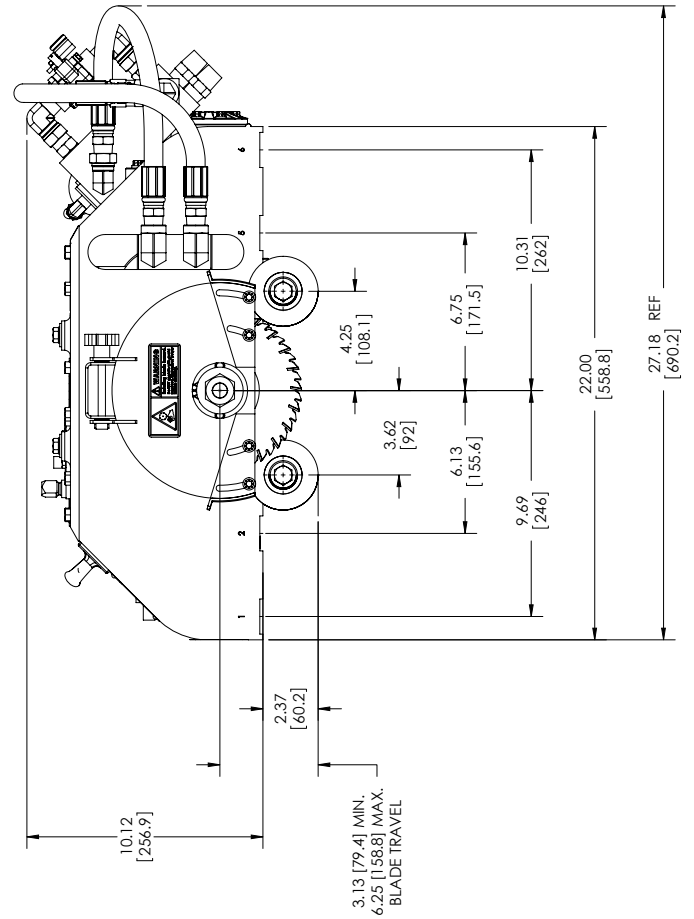
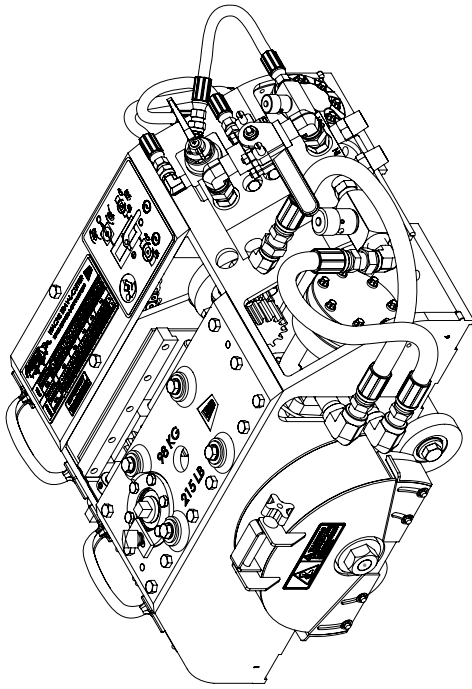
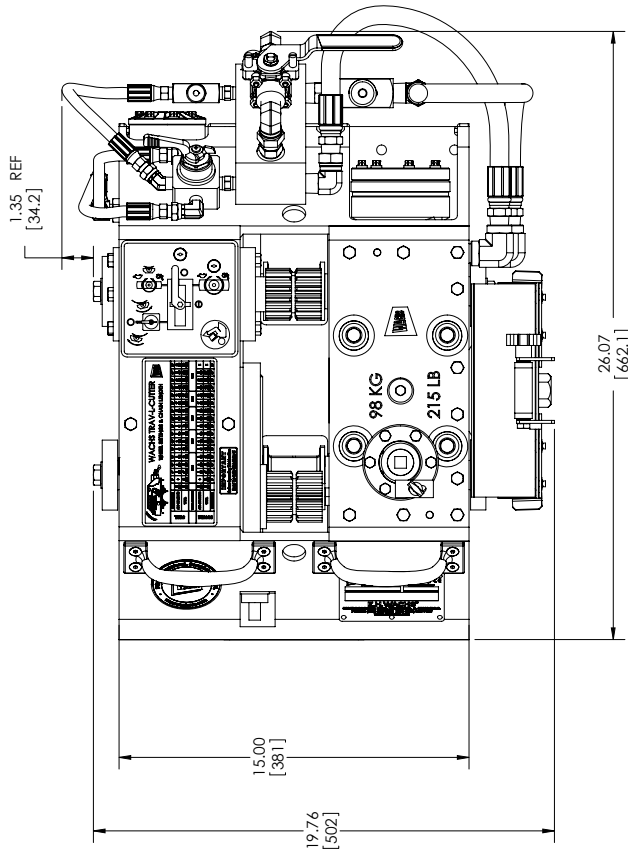

Operating Envelope  
Trav-L-Cutter Assembly, Hydraulic Drive  
02-000-02

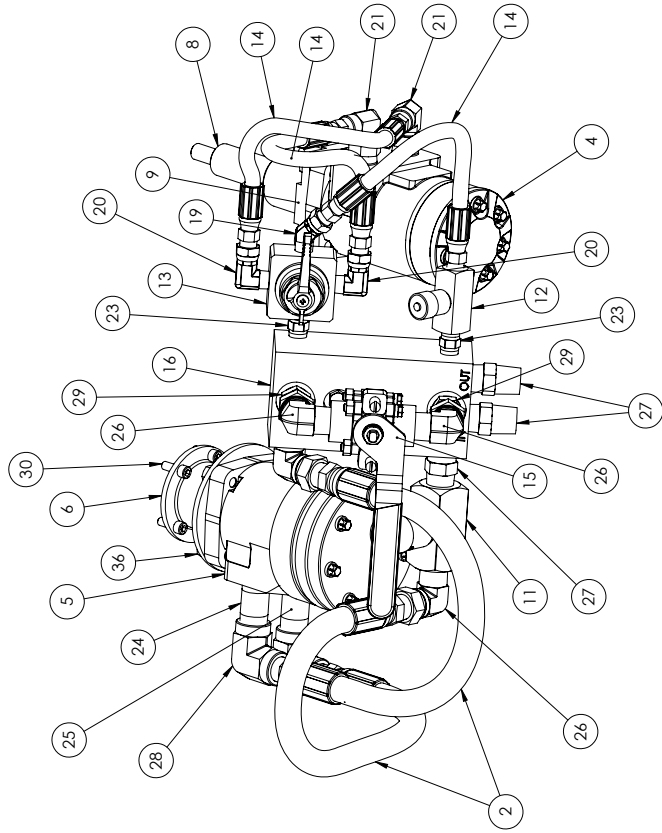

**TRAV-L-CUTTER  
HYDRAULIC SYSTEM COMPONENTS  
INPUT REQUIREMENTS**  
2000 PSI [138 bar] MAX.  
15 GPM [57 L/MINUTE]

ITEM	PART NUMBER	QTY.	DESCRIPTION
1	02-009-00	1	LABEL, PRESSURE-HYD. (NOT SHOWN)
2	02-027-01	2	HOSE, 1/2" HP X 30" LONG
3	02-199-00	1	MOTOR COUPLING, DRIVE PIN
4	02-200-00	1	HYDRAULIC MOTOR, CARRIAGE DRIVE
5	02-201-00	1	HYDRAULIC MOTOR, CUTTER SPINDLE
6	02-202-00	1	ADAPTER, CUTTER SPINDLE MOTOR
7	02-203-00	1	COUPLING, MOTOR (NOT SHOWN)
8	02-204-00	1	DRIVE MOTOR ADAPTER
9	02-205-00	1	BRACKET, MOUNTING-DRIVE MOTOR
10	02-206-01	1	SHIM, HYDRAULIC GEAR BOX (NOT SHOWN)
11	02-211-00	1	1/2" FLOW CONTROL VALVE
12	02-212-00	1	FLOW CONTROL VALVE 1/4"
13	02-213-00	1	1/4" 4-WAY VALVE REVERSING
14	02-214-01	3	1/4" HP HOSE ASSEMBLY
15	02-215-00	1	1/2" ON/OFF VALVE
16	02-218-00	1	MANIFOLD
17	02-298-00	1	LABEL, TRAV-L-CUTTER HYD. (NOT SHOWN)
18	90-029-44	1	KEY 1/8 X 1/2 #3 WOODRUFF (404) (NOT SHOWN)
19	90-058-51	1	ADAPTER, 1/4 NPT M X 1/4 NPT F SWIVEL-45
20	90-058-52	2	ADAPTER, 1/4 NPT M X 1/4 NPT F SWIVEL-90
21	90-058-56	2	ELBOW, 1/4-90 HP STREET
22	90-058-57	2	BUSHING, 1/2 X 1/4 HP REDUCING (NOT SHOWN)
23	90-058-58	2	NIPPLE, 1/4 HEX H.P.
24	90-098-52	1	NIPPLE, 1/2" X 2" SCH 80 A106 B
25	90-098-53	1	NIPPLE, 1/2" X 2-1/2" SCH 80 A106 B
26	90-098-55	4	ADAPTER, 1/2" NPT M X 1/2" NPT F SWIVEL-90
27	90-098-58	3	1/2 HEX HP NIPPLE
28	90-098-60	2	ADAPTER, 1/2" NPT F X 1/2" NPT F-90
29	90-098-79	2	ADAPTER, 1/2 NPT M X 1/2 ORB M - STRAIGHT
30	90-150-07	5	SHCS, 1/4-20 X 3/4, SS18-8
31	90-153-12	4	FHCS, 1/4-20 X 1-1/4 SS18-8 (NOT SHOWN)
32	90-161-10	4	HHCS, 5/16-18 X 1 SS18-8 (NOT SHOWN)
33	90-161-27	2	HHCS, 5/16-18 X 2-3/4 SS18-8 (NOT SHOWN)
34	90-165-01	2	NUT, 5/16-18 HEX SS18-8 (NOT SHOWN)
35	90-165-52	2	WASHER, 5/16 FLAT SS18-8
36	90-171-07	4	HHCS, 3/8-16 X 3/4 SS18-8
37	90-171-08	4	HHCS, 3/8-16 X 7/8 SS18-8 (NOT SHOWN)

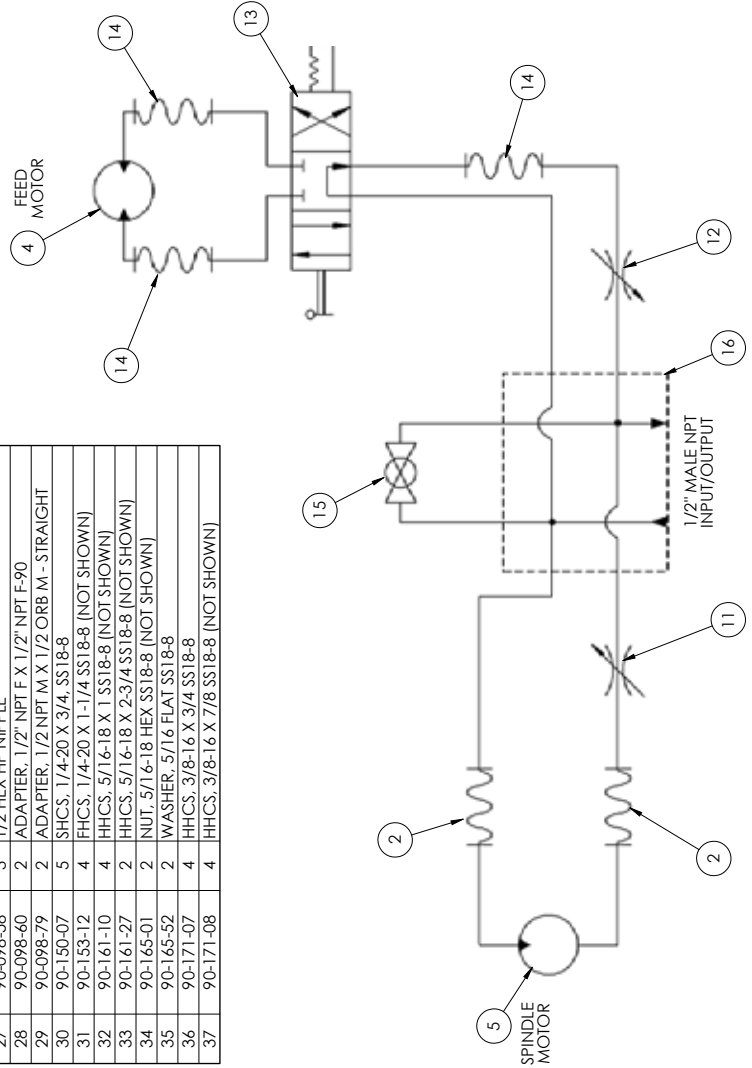

## Chapter 4

# Setup and Operating Procedures

---

### WHEEL SETTINGS

PIP E Ø 6.00" – 13.99" (152-355mm)

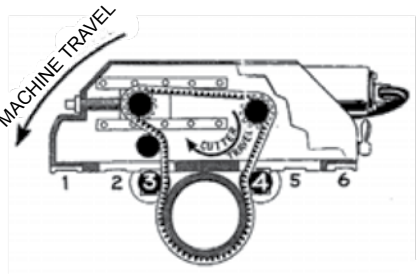

WHEEL POSITION 3 & 4

PIP E Ø 14.00" – 19.99" (356-508mm)

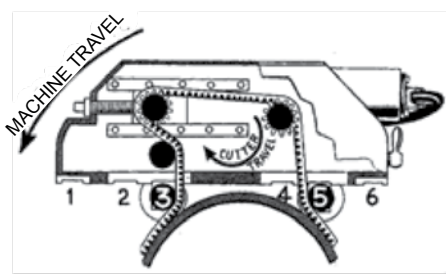

WHEEL POSITION 3 & 5

PIP E Ø 20.00" – 35.99" (508-914mm)

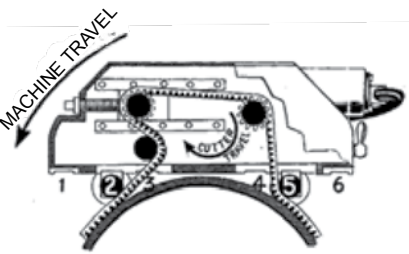

WHEEL POSITION 2 & 5

PIP E Ø 36.00" – 47.99" (914-1219mm)

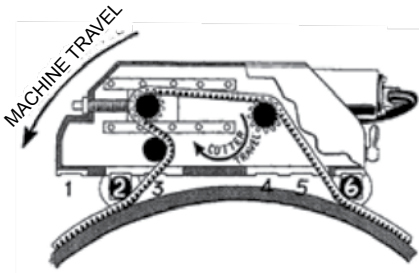

WHEEL POSITION 2 & 6

PIP E Ø 48.00" – 72.00" (1219-1829mm)

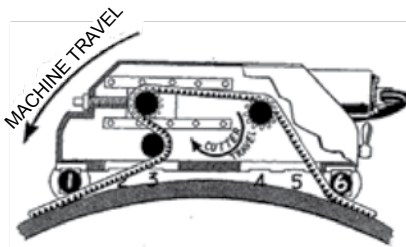

WHEEL POSITION 1 & 6

## CHAIN LENGTHS



PIPE SIZE	TYPE DI/S <sup>1</sup>	PIPE DIA.	ADD ON LENGTH <sup>2</sup>	PART NUMBER	TOTAL LENGTH	ACCUMULATED CHAIN ASSEMBLIES	
6"	S	6.625" (168mm)	0	02-457-06	42" (1067mm)	N/A	
	Di	6.90" (175mm)					
8"	S	8.625" (219mm)	5" (127mm)	02-457-08	47" (1194mm)		
	Di	9.05" (230mm)					
10"	S	10.75" (273mm)	8" (203mm)	02-457-10	55" (1397mm)		02-450-10
	Di	11.10" (282mm)					
12"	S	12.75" (324mm)	6" (152mm)	02-457-12	61" (1549mm)	02-450-12	
	Di	13.20" (335mm)					
14"	S	14.00" (356mm)	2" (51mm)	02-457-14	63" (1600mm)	02-450-14	
	Di	15.30" (389mm)					
16"	S	16.00" (406mm)	6" (152mm)	02-457-16	69" (1752mm)	02-450-16	
	Di	17.40" (442mm)					
18"	S	18.00" (457mm)	7" (179mm)	02-457-18	76" (1930mm)	02-450-18	
	Di	19.50" (495mm)					
20"	S	20.00" (508mm)	2" (51mm)	02-457-20	78" (1981mm)	02-450-20	
	Di	21.60" (549mm)	7" (179mm)	02-457-20-D	83" (2108mm)	02-450-20-D	
24"	S	24.00" (610mm)	13" (330mm)	02-457-24	91" (2312mm)	02-450-24	
	Di	25.80" (655mm)			96" (2438mm)		
30"	S	30.00" (762mm)	20" (508mm)	02-457-30	111" (2819mm)	02-450-30	
	Di	32.00" (813mm)			116" (2946mm)		
36"	S	36.00" (915mm)	17" (432mm)	02-457-36	128" (3251mm)	02-450-36	
	Di	38.30" (973mm)			133" (3378mm)		
42"	S	42.00" (1067mm)	19" (482mm)	02-457-42	147" (3734mm)	02-450-42	
	Di	44.50" (1130mm)			152" (3861mm)		
48"	S	48.00" (1219mm)	17" (432mm)	02-457-48	164" (4166mm)	02-450-48	
	Di	50.80" (1290mm)	21" (533mm)	02-457-48-D	173" (4394mm)	02-450-48-D	
54"	S	54.00" (1372mm)	20" (508mm)	02-457-54	184" (4674mm)	02-450-54	
	Di	57.26" (1454mm)			194" (4928mm)		
60"	S	60.00" (1524mm)	18" (458mm)	02-457-60	202" (5131mm)	02-450-60	
	Di	61.61" (1565mm)	13" (330mm)	02-457-60-D	207" (5258mm)	02-450-60-D	
72"	S	72.00" (1829mm)	38" (965mm)	02-457-72	240" (6096mm)	02-450-72	

<sup>1</sup> S - STEEL PIPE MEASUREMENTS - PER ASME B36.19M-2004

DI- DUCTILE-IRON PIPE MEASUREMENTS - PER ANSI/AWWA C151/A21.51-91

<sup>2</sup> REQUIRES 42" (1067mm) BASE CHAIN AND ALL PREVIOUS ADD ON LENGTHS

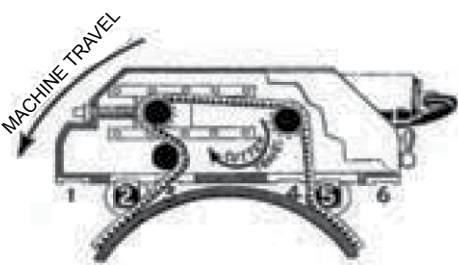
## WHEEL SETTINGS AND CHAIN LENGTH

																		
STEEL	PIPE DIAMETER		6"	8"	10"	12"	14"	16"	18"	20"	24"	30"	36"	42"	48"	54"	60"	72"
	ADD ON LENGTH	IN MM	0	5 127	8 203	6 152	2 51	6 152	7 179	2 51	13 330	20 508	17 432	19 482	17 432	20 508	18 458	38 965
	TOTAL	IN MM	42 1067	47 1194	55 1397	61 1549	63 1600	69 1752	76 1930	78 1981	91 2312	111 2819	128 3251	147 3734	164 4166	184 4674	202 5131	240 6096
WHEEL POSITION			3 & 4				3 & 5			2 & 5			2 & 6		1 & 6			
DUCTILE	ADD ON LENGTH	IN MM	0	5 127	8 203	6 152	2 51	6 152	7 179	7 179	13 330	20 508	17 432	19 482	21 533	20 508	13 330	X
	TOTAL	IN MM	42 1067	47 1194	55 1397	61 1549	63 1600	69 1752	76 1930	83 2108	96 2438	116 2946	133 3378	152 3861	173 4394	194 4928	207 5258	X
	PIPE DIAMETER		6"	8"	10"	12"	14"	16"	18"	20"	24"	30"	36"	42"	48"	54"	60"	72"

### Chain Length Calculations

You can calculate the required chain length for any size pipe using the following formulas.

Pipe O.D.	Wheel Positions	Chain length Formula
6.0"-13.99" (168-355 mm)	3 and 4	3.235 x (Pipe Diameter in Inches) + 19.06" 3.235 x (Pipe Diameter in mm) + 484 mm
14"- 19.99" (356-507 mm)	3 and 5	3.204 x (Pipe Diameter in Inches) + 16.33" 3.204 x (Pipe Diameter in mm) + 415 mm
20"-35.99" 508-914 mm	2 and 5	3.175 x (Pipe Diameter in Inches) + 14.98" 3.175 x (Pipe Diameter in mm) + 380 mm
36"-47.99" (915-1218 mm)	2 and 6	3.162 x (Pipe Diameter in Inches) + 12.82" 3.162 x (Pipe Diameter in mm) + 326 mm
48"-72" (1219-1829 mm)	1 and 6	3.149 x (Pipe Diameter in Inches) + 12.61" 3.149 x (Pipe Diameter in mm) + 320 mm

Note that there is some overlap in acceptable wheel positions between size ranges.

## MACHINE INSTALLATION

The **Wachs Trav-L-Cutter (TLC)** is shipped from the factory completely assembled and lubricated. It is only necessary to mount the machine, install the cutting wheel and connect the power supply. Please observe the following warning stickers located on the TLC before proceeding to operate machine.

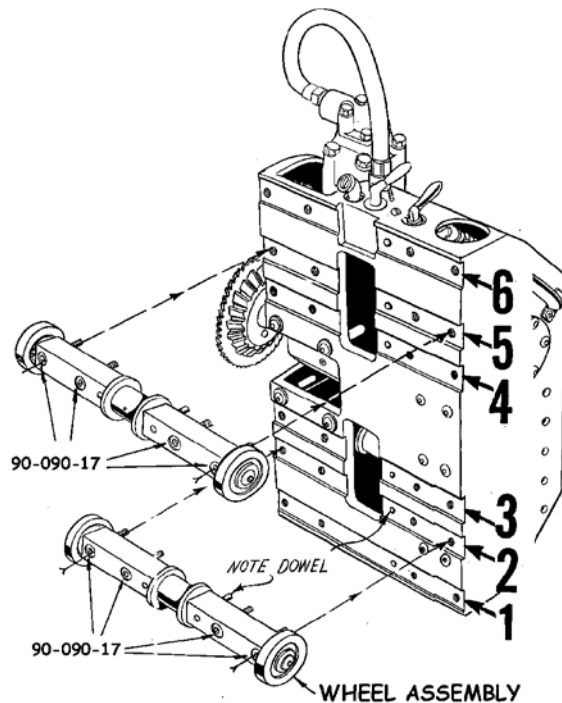

Figure 4-1. Machine Installation

1. Refer to the Section on Wheel Setting and Chain Lengths and determine the proper wheel position for the size of pipe to be cut. If the wheel assemblies are not in the proper slots, the eight 1/2" socket head cap screws (Part No. 90-090-17) shown in figure 1 should be removed and the wheel assemblies taken from the carriage. Place the wheel assemblies in the proper slots in the carriage. Make sure the protruding dowel pins (Part No. 90-076-20) are inserted in the dowel pin holes. Replace the eight 1/2" socket head cap screws and tighten securely.
2. Check and make sure the cutter spindle is in its uppermost position.

To raise the cutter spindle, loosen the thumbscrew (Part No. 90-059-04) and slide feed screw lock (Part No. 02-008-00) back. With the aid of the socket wrench turn the feed screw in a counter clockwise direction until the cutter spindle is raised to its highest position.

3. From the Section on Wheel Setting and Chain Length, select the combination of chain segments to make up the required length of chain.

Each segment of chain is marked for easy identification.

Starting with the basic length of chain marked 6 (42” long section) add the necessary chain segments to make up the proper length. When assembling the segments of chain to the basic length be sure they are assembled male end to female end. Don’t try to join ends where numbers come together. The lengths of the chain will engage freely if they are clean.

The chain segments are coupled with special chain connecting pins (Part No. 02-158-00) furnished with the chain.

When connecting the chain segments it is best that they be placed on a flat surface to simplify the joining of the links. Use the lineup pin (Part No. 02-159-00) to get the joining links in proper alignment. When the chain links are aligned push the lineup pin out of the chain by inserting a connecting pin from the opposite side.

4. Turn the chain tension screw (Part No. 02-081-01) counter clockwise to move the chain tension idler sprocket to its innermost position.
5. Thread the assembled chain through the machine as shown in the section on Wheel Setting and Chain Length (inside cover). Leave six inches protruding on valve end of machine – balance of chain on other end.
6. Place the machine on the pipe and join the open ends of the chain with a connecting pin as shown in sketch for chain assembly (Figure 3, p. 16). To assist in getting chain square on pipe, rock machine after chain has been connected but before it has been tightened.



## CAUTION

During chain connection, one person should hold cutter steady on pipe. Failure to do so could cause serious injury.

7. Tighten the chain by turning the chain tension screw in a clockwise direction. The chain will be properly tensioned when the torque wrench is applied to the chain tension screw and it registers 80 to 85 foot pounds (green line on torque wrench).
8. Recheck chain tension frequently on large diameter or heavy wall pipe cutting.
9. Remove lock nut (Part No. 02-014-00) and driving collar spacer (Part No. 02-022-01) cutter spindle.
10. Select the proper cutter from Cutter Chart on pages 20-21 and place cutter on cutter spindle. In as much as the cutter rotates in a clockwise direction as you face it, the cutter should be placed on the spindle so the flat, sharp cutting edges lead into the pipe. Place the driving collar spacer on the spindle and lock the spacer and cutter tightly to the spindle with the lock nut.

**NOTE**

Left hand thread in nut turns counter clockwise to tighten. Be sure the cutter drive collar spacer and lock nut are clean and free of chips and dirt so that the assembly can be tightened securely.

**NOTE**

It is important to use sharp cutters. A dull cutter puts an unnecessary load on the machine and will result in unsatisfactory cuts. Cutters should be sharpened by a qualified tool grinder who has equipment to maintain the cutter angles and shape. A tool grinder who caters to machine shops or tool and die shops is best. Please contact your E.H. Wachs representative for further details regarding tool sharpening services.

---

**OPERATING THE MACHINE**

1. Connect the power supply to hose whip on Pipe Cutter.

**CAUTION**

Be sure the valves on the machine are off before supplying air to the machine. When the handles on air valves are up they are in the OFF position.

2. With the power supply turned on the machine is ready to cut the pipe. Turn the valve handle on Cutter Valve 90° to the right. This will put the cutter spindle motor in operation and rotate the cutter.
3. Slowly feed the rotating cutter down until it extends through the wall of the pipe by approximately 1/4". This is done by turning the feed screw (Part No. 02-001-00) in a clockwise direction. One complete turn of the feed screw lowers the cutter 1/10". Lock the cutter in position by placing the feed screw lock (Part No. 02-008-00) on the shoulder of the feed screw and lock in place with the thumb screw (Part No. 90-059-04).
4. Turn valve handle on Feed Valve 90° to the right. This will operate the drive motor and make the machine travel around the pipe and make a complete cut. Speed may be reduced by adjustment of the feed valve handle (close slowly until proper speed is attained). Machine is traveling too fast if wheel to right of cutter lifts off pipe or if machine is vibrating excessively.
5. When the cut is completed stop the drive motor by turning Feed Valve to the left until machine stops. With the cutter still rotating release the elevating screw lock and raise the cutter to its uppermost position. With the cutter raised, stop the cutter motor by turning Cutter Valve to the left 90°. Remove the cutter from the machine. Release the tension on the drive chain by turning the chain tension screw counter clockwise. Remove a connecting pin from the chain to uncouple it and the machine can now be removed from the pipe.



## Special Instructions for Assembling 2" Wide Drive Chain

As shown on the right, all sections of the chain have one female end and one male end. One outside link on the female end of the chain is stamped with the Chain Section Number.

In assembling the chain, always start with the basic length marked 6 (42" long section) and add the required number of sections of chain, in the proper sequence, until the desired length is obtained.

**EXAMPLE:** Assemble Chain for 12" pipe. Start with the basic length marked 6 and add to it, in sequence, the pieces marked 8, 10, & 12. If this chain is correctly assembled it will be the proper length to be threaded through the Trav-LCutter and wrapped around a 12" pipe as shown in the 1st picture under Wheel Settings and Chain Lengths on the inside front cover of this manual.

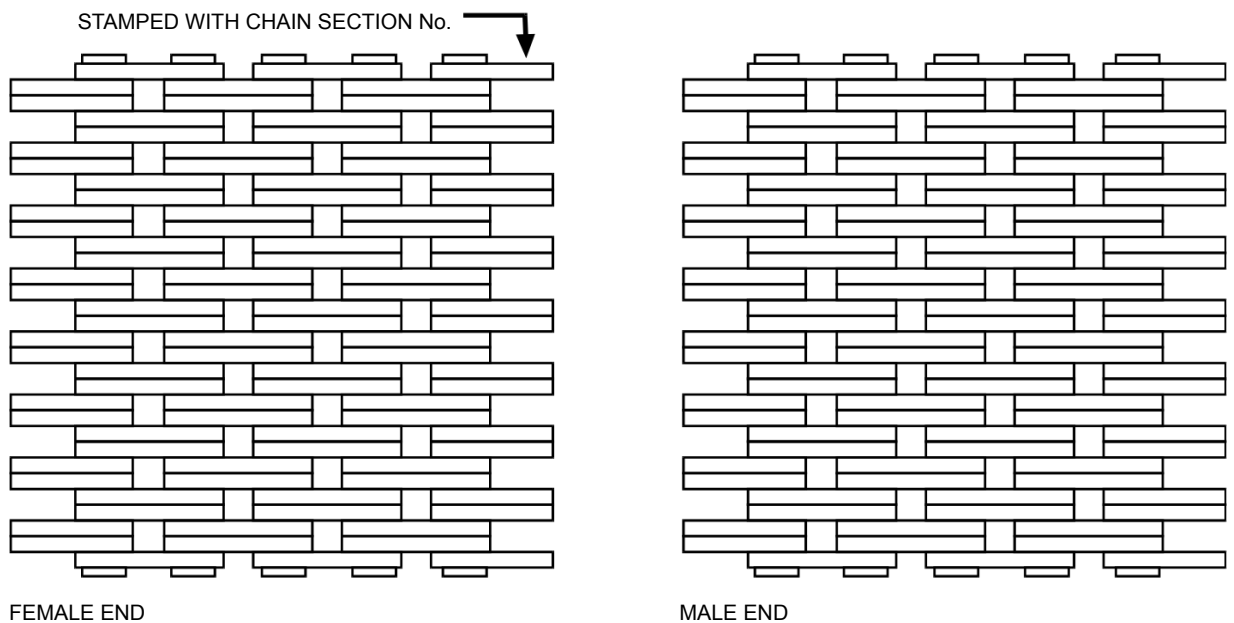

NOTE: To convert inches to centimeters multiply by 2.54

Figure 4-2. Assembling 2" Wide Drive Chain



### NOTE

When cutting medium and large diameter thin wall steel pipe it may be found that the prescribed length of chain will be too long to be properly tensioned. If this is the case, remove a section of chain so that the total length will be of a size that can be properly tensioned.



## WARNING

ALWAYS CONNECT THE MALE END OF ONE SECTION TO THE FEMALE END OF THE SECTION OF CHAIN THAT PRECEDES IT.

NEVER CONNECT TWO MALE ENDS OR TWO FEMALE ENDS OF CHAIN TOGETHER AS THIS WILL THROW THE CHAIN OUT OF LINE AND WILL CAUSE MALFUNCTION OF THE TRAV-LCUTTER AND CHAIN AND SPROCKET BREAKAGE.

### Operating Hints

- 1.** It is good practice to drive steel wedges (p/n: 02-175-00) into the saw cut to prevent the pipe from binding on cutter.
- 2.** Sharp cutters will ensure safe, accurate, dependable cuts. The cutter will stay sharp longer if cast iron pipe is wire brushed at the point where the cutter is first fed through the wall of the pipe.
- 3.** The air motors will operate best with a minimum air pressure of 90 psi. and volume of approximately 100 cu. ft. per minute.
- 4.** Cut cast iron and ductile iron pipe dry. Use a thread cutting oil or a water soluble cutting oil on steel and stainless steel pipe to lubricate the cutters and help maintain sharpness.
- 5.** Use a Wachs guide track when cutting in a vertical position or when exact accuracy is required. See the drawing at the end of this chapter.
- 6.** Adjust the feed rate to reduce or eliminate cutter overload. Feed valve must be opened very slowly to achieve a slower feed rate. For complete control of feed speed, install needle valve in feed motor air line.
- 7.** To confirm pipe squareness, use a pipe wrap to establish a square cut line and measure from this line to the chain in several places on pipe O.D.
- 8.** The maximum effective cutting rate for the Trav-L-Cutter on ductile iron is approximately one minute per inch of diameter. Some cast iron, steel, heavy wall pipe and beveling will require a slower feed rate.

## Setup Using the Guide Track

DIMENSIONS IN BRACKETS ARE MILLIMETERS

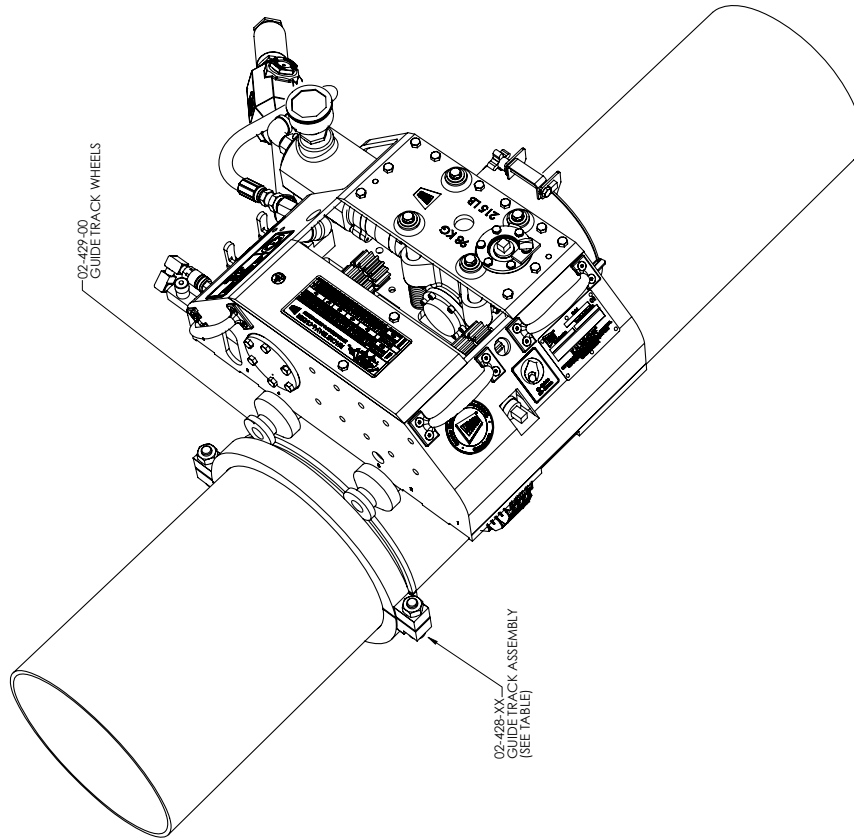

-TABLE-

PART NO.	ASSEMBLY NO.	TRACK ID.	TRACK O.D.	APPLICATION
02-207-06	02-428-06	6.66 [169.0]	8.66 [219.8]	
02-207-08	02-428-08	8.66 [219.8]	10.66 [270.6]	
02-207-10	02-428-10	10.78 [273.8]	12.78 [324.6]	
02-207-12	02-428-12	12.78 [324.6]	14.78 [375.4]	
02-207-14	02-428-14	14.03 [356.4]	16.03 [407.2]	
02-207-16	02-428-16	16.03 [407.2]	18.03 [458.0]	
02-207-18	02-428-18	18.03 [458.0]	20.03 [508.8]	
02-207-20	02-428-20	20.03 [508.8]	22.03 [559.6]	
02-207-22	02-428-22	22.03 [559.6]	24.03 [610.4]	
02-207-24	02-428-24	24.03 [610.4]	26.03 [661.2]	
02-207-26	02-428-26	26.03 [661.2]	28.03 [712.0]	
02-207-28	02-428-28	28.03 [712.0]	30.03 [762.8]	
02-207-30	02-428-30	30.03 [762.8]	32.03 [813.6]	
02-207-32	02-428-32	32.03 [813.6]	34.03 [864.4]	
02-207-34	02-428-34	34.03 [864.4]	36.03 [915.2]	
02-207-36	02-428-36	36.03 [915.2]	38.03 [966.0]	
02-207-38	02-428-38	38.03 [966.0]	40.03 [1016.8]	
02-207-40	02-428-40	40.03 [1016.8]	42.03 [1067.6]	
02-207-42	02-428-42	42.03 [1067.6]	44.03 [1118.4]	
02-207-48	02-428-48	48.03 [1220.0]	50.03 [1270.8]	
				30" [762] DUCTILE IRON PIPE

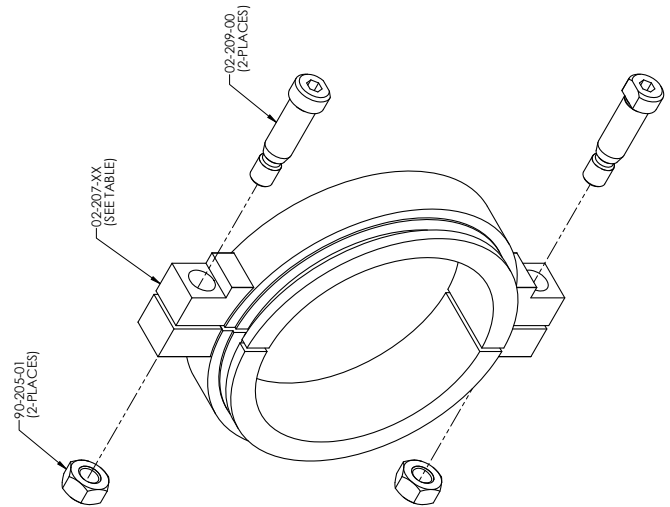



## Chapter 5

# Maintenance

---

### LUBRICATION INSTRUCTIONS

All the Ball Bearings in the machine are sealed and require no further lubrication. The bronze bushings are composed of Sintered Bronze and are oil impregnated and should require no further lubrication under normal conditions. Under severe conditions, a light coating of oil should be applied to the bushings in the Chain Guide Rollers and in the Chain Tension Sprocket.

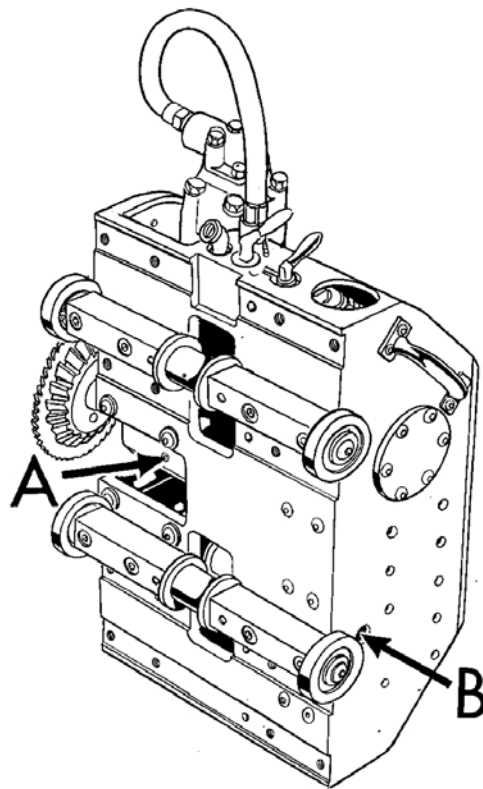

*Figure 5-1. Checking the Oil Level*

The Cutter Spindle Gear Box (p/n 02-020-00) and the Carriage Drive Gear Box (p/n 02-02-194-00) are filled with the required amount of Heavy Duty Worm Gear Oil at the factory. However, the oil in these gear boxes should be checked before each use and oil added if required.

To check the oil level in the Cutter Spindle Gear Box, (A) stand the saw upright as shown in Figure 5-1. Using an allen wrench, remove the plug (p/n 90-028-01) from the bottom of the gear box. If no oil is running out of hole, add Heavy Duty Worm Gear Oil (p/n 02-401-00) with an oil can until oil is running out of hole. Replace plug.

To check oil level in Drive Gear Box (p/n 02-194-00) (B), remove Trav-L-Cutter cover (p/n 02-135-00). Set machine on its wheels and remove front plug and top plug. Fill through top hole with Heavy Duty Worm Gear Oil until oil runs out of front hole. No lubrication is necessary on drive chain.

The chain will be adequately lubricated when washed clean with kerosene. This is very important when storing your Trav-L-Cutter for extended periods of time. Place a light coating of oil on Feed Screw (p/n 02-001-00), Chain Tensioning Screw (p/n 02-081-01) and Guide Rods (p/n 02-019-00 or 02-019-02 for atmospheric models).

## Chapter 6

# Consumable Select Chart

---

### DATA ON CUTTER SIZE

Use a 6" diameter cutter for up to 1" wall.

Use a 7" diameter cutter for up to 1-1/2" wall.

Use a carbide tipped cutter for cutting cement lined or cast iron pipe. Heavy wall cast iron pipe may require the use of the next larger size cutter. If the wall thickness of the pipe is unknown, feed the cutter into the pipe as far as possible and then retract it so that the cut can be inspected to determine if a larger cutter is needed.

The gang of cutters for beveling pipe is designed for use on steel pipe up to 5/8" wall for making a weld preparation. The standard bevel is 37.5°.

**SPECIAL APPLICATION BLADES CAN BE PRODUCED ON SPECIAL ORDER.  
PLEASE CONTACT YOUR WACHS REPRESENTATIVE FOR FURTHER DETAILS.**



5" Left Hand Bevel Cutter



5" Right Hand Bevel Cutter

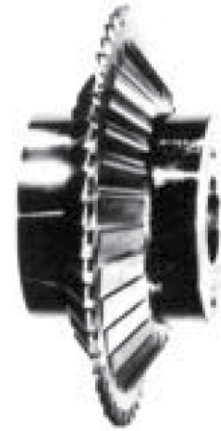

Gang of Cutters for Beveling Pipe Consists of  
One 5" RH Bevel  
One 6" Cutter for steel pipe  
One 5" LH Bevel  
All mounted on drive collars.



8" for Steel Pipe  
H.S.S.

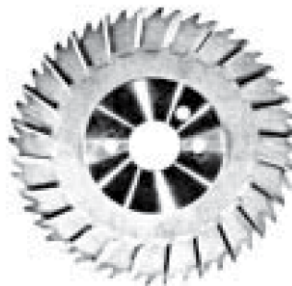

7" for Steel Pipe  
H.S.S.



6" for Steel Pipe  
H.S.S.

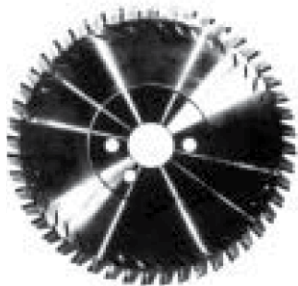

8" for Cast Iron and Cement Lined Pipe; Carbide Tipped

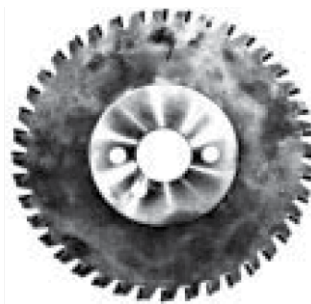

7" for Cast Iron and Cement Lined Pipe; Carbide Tipped

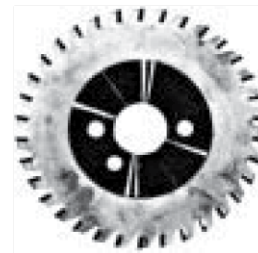

6" for Cast Iron and Cement Lined Pipe; Carbide Tipped

Figure 6-1. Consumable Selection Chart



**CUTTERS****SLITTING SAWS**

<b>PART NO.</b>	<b>SIZE</b>	<b>APPLICATION</b>
02-601-00	6" X 3/16" H.S.S.	FOR STEEL PIPE UP TO 1" WALL
02-602-00	7" X 3/16" H.S.S.	FOR STEEL PIPE UP TO 1-1/2" WALL
02-604-00	8" X 3/16" H.S.S.	FOR STEEL PIPE UP TO 2" WALL

H.S.S. = HIGH SPEED STEEL

**CARBIDE TIPPED SAW**

<b>PART NO.</b>	<b>SIZE</b>	<b>APPLICATION</b>
02-605-00	6" X 3/16"	FOR CAST IRON AND CEMENT LINED PIPE UP TO 1" WALL
02-606-00	7" X 3/16"	FOR CAST IRON AND CEMENT LINED PIPE UP TO 1-1/2" WALL
02-607-00	8" X 3/16"	FOR CAST IRON AND CEMENT LINED PIPE UP TO 2" WALL

**BEVEL CUTTER**

<b>PART NO.</b>	<b>SIZE</b>	<b>APPLICATION</b>
02-608-LH 02-608-RH	5" X 30°	MAXIMUM WALL PENETRATION 3/4"
02-609-LH 02-609-RH	5" X 37-1/2°	MAXIMUM WALL PENETRATION 5/8"
02-610-LH 02-610-RH	6" X 30°	MAXIMUM WALL PENETRATION 1"
02-611-LH 02-611-RH	6" X 37-1/2°	MAXIMUM WALL PENETRATION 7/8"



## Chapter 7

# Troubleshooting Problems

<b>Trouble</b>	<b>Possible Cause</b>	<b>Remedy</b>
<b>1. Cutter motor and cutter stall</b>	1. Air motor icing	Use Wachs special antifreeze oil
	2. Dull cutter	Replace dull cutter
	3. Insufficient air supply	Check air supply for 90 psi 100 CFM
	4. Dirty air filter element #02-164-00	Replace 02-164-00 (Do not try to clean and replace)
	5. Saw feeding too fast or too much material being removed in 1 pass	Adjust feed and depth of cut
	6. Loss of oil in cutter gear box	Add oil and check for leaks
	7. Dirt, corrosion or broken vanes in air motor	Add oil and check for leaks
<b>2. Chain drive sprocket breakage</b>	1. Damaged chain	Replace
	2. Chain connected incorrectly	Check connection points and correct
	3. Connection pin not fully inserted	Insert completely or replace if damaged
<b>3. Not cutting straight or poor closure</b>	1. Poorly aligned chain	Check set up (see Page 2)
	2. Dull cutter	Change cutter
	3. Inclined or vertical pipe	Use Wachs guide track
	4. Cutter overload	Re-adjust feed
<b>4. Machine feed inoperative</b>	1. Dirt and corrosion in drive air motor	Flush with alcohol or mineral spirits and reoil. With air on, tap clutch with wood stick in CCW direction from rear of motor.
	2. Clutch slipping	Loosen (2) set screws #90-044-53 & tighten hex nut #90-055-02. Retighten set screws.
	3. On-off valve failure or obstruction	Return machine or valve manifold to E.H. Wachs Co. for repair.

<b>Trouble</b>	<b>Possible Cause</b>	<b>Remedy</b>
<b>5. Excessive vibration</b>	1. Feed too fast	Slow feed
	2. Cutter too deep	Raise cutter
	3. Dull cutter	Replace cutter
	4. Drive chain loose	Check tension per instructions
	5. Cutter installed backwards	Replace cutter and install per instructions
	6. Excessive wear on cutter gear box guide rods	Return to E.H. Wachs for repair

## **Chapter 8**

# **Parts Lists & Exploded View Drawings**

ITEM	PART NUMBER	QTY.	DESCRIPTION
1	02-157-00	1	SILENT CHAIN
2	02-158-00	1	CONNECTING PIN FOR CHAIN
3	02-303-00	1	OILER ASSEMBLY
4	02-312-00	1	PNEUMATIC CARRIAGE ASSEMBLY
5	02-MAN-01	1	MANUAL (NOT SHOWN)
6	02-125-00	1	LABEL-SCALE, CHAIN LENGTH (NOT SHOWN)
7	02-155-00	1	STEEL CABLE (NOT SHOWN)
8	02-159-00	1	LINE-UP PIN (NOT SHOWN)
9	02-162-00	1	WRENCH, TORQUE (NOT SHOWN)
10	02-175-00	3	STEEL WEDGE (NOT SHOWN)
11	02-176-00	1	STORAGE CASE (NOT SHOWN)
12	02-177-00	1	CASE/DIVIDER FOR BLADES (NOT SHOWN)
13	02-287-00	1	WHEEL SETTING CHART (NOT SHOWN)
14	02-289-00	1	CHAIN LENGTHS CHART (NOT SHOWN)
15	90-800-01	1	WRENCH, 1-1/4 OPEN END (NOT SHOWN)
16	90-800-05	1	WRENCH, 1/2 DRV. BREAKER BAR (NOT SHOWN)
17	90-800-10	1	WRENCH, 3/8 HEX LONG ARM (NOT SHOWN)
18	90-800-11	2	SOCKET, 1/2 DRV. X 1/2 8PT. IMPACT (NOT SHOWN)

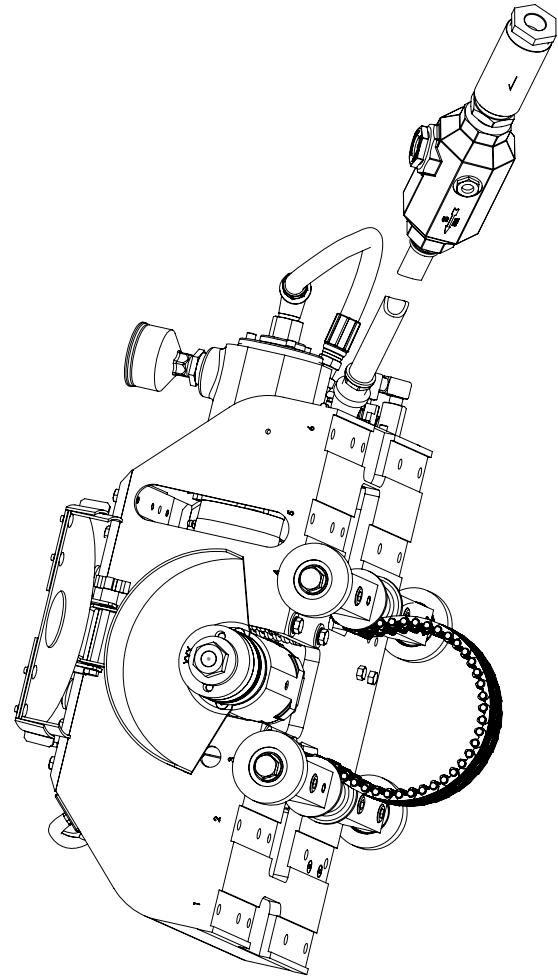
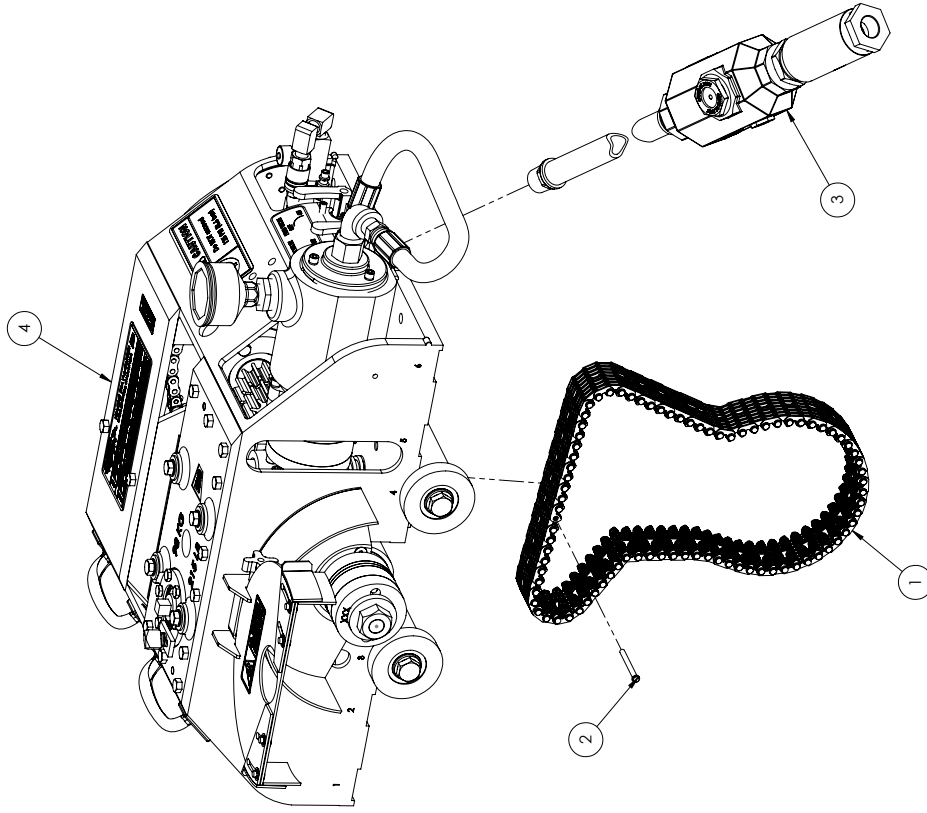

Trav-L-Cutter Assembly, Air Drive  
02-000-01

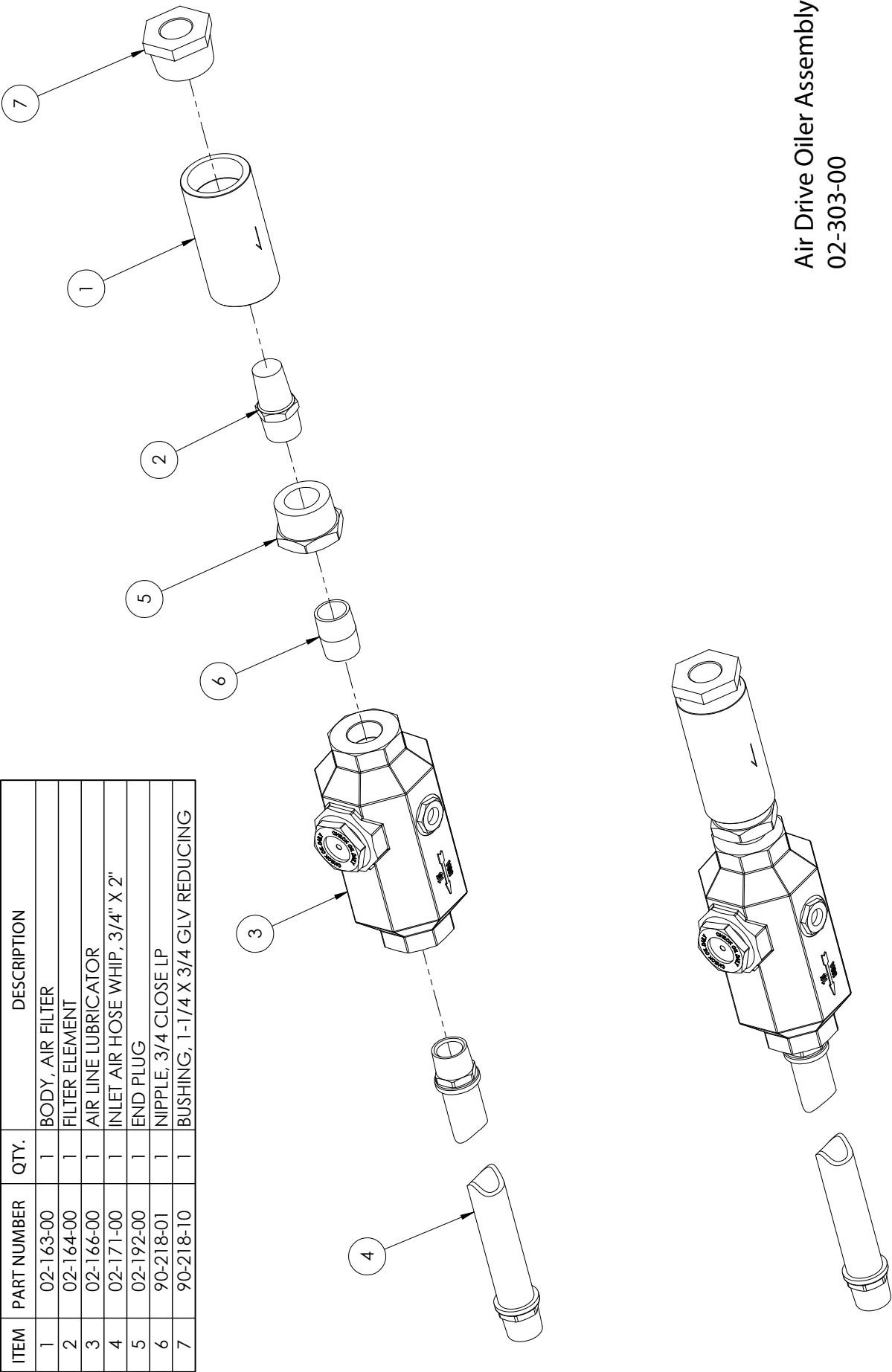

Air Drive Oiler Assembly  
02-303-00

ITEM	PART NUMBER	QTY.	DESCRIPTION
1	02-163-00	1	BODY, AIR FILTER
2	02-164-00	1	FILTER ELEMENT
3	02-166-00	1	AIR LINE LUBRICATOR
4	02-171-00	1	INLET AIR HOSE WHIP, 3/4" X 2"
5	02-192-00	1	END PLUG
6	90-218-01	1	NIPPLE, 3/4 CLOSE LP
7	90-218-10	1	BUSHING, 1-1/4 X 3/4 GLV REDUCING

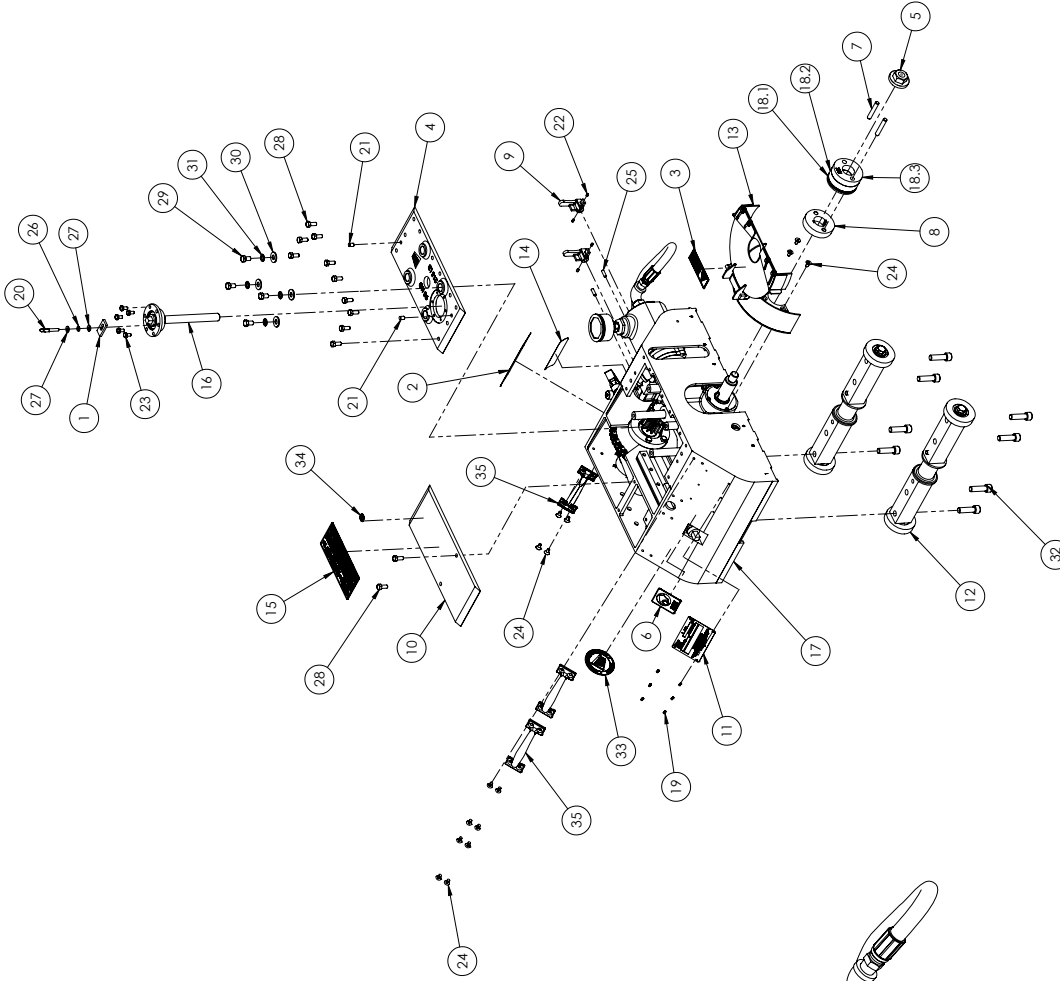

Pneumatic Carriage Assembly  
02-312-00

ITEM	PART NUMBER	QTY.	DESCRIPTION
1	02-008-00	1	LOCK, FEED SCREW
2	02-010-00	1	LABEL, PRESSURE-AIR
3	02-011-00	1	LABEL, WARNING-BLADE GUARD
4	02-013-00	1	COVER, SPINDLE CARRIAGE
5	02-014-00	1	LOCK NUT, DRIVE COLLAR
6	02-015-00	1	LABEL, TORQUE
7	02-021-01	2	PIN, CUTTER DRIVE
8	02-022-01	1	COLLAR, CUTTER DRIVE
9	02-124-00	2	HANDLE, AIR VALVE
10	02-135-00	1	COVER, DRIVE SIDE
11	02-141-00	1	NAME PLATE
12	02-142-00	2	WHEEL ASSEMBLY
13	02-179-00	1	CUTTER GUARD ASSEMBLY
14	02-185-00	1	LABEL, ON-OFF
15	02-300-00	1	MACHINE CHAIN & WHEEL CHART
16	02-304-00	1	FEED SCREW ASSEMBLY
17	02-311-00	1	AIR MOTOR AND FRAME ASSEMBLY
18	02-500-03	2	KIT, CUTTER SPACERS 3/16, 11/16, & 3/4
18.1	02-290-03	2	SPACER, TRAV-L-CUTTER
18.2	02-290-17	1	SPACER, TRAV-L-CUTTER
18.3	02-290-20	1	SPACER, TRAV-L-CUTTER
19	90-048-01	6	SCREW, #4 X 1/4 ROUND U-DRIVE SS18-8
20	90-059-04	1	SCREW, 1/4 X 1/4 ROUND X 1-1/4 THUMB
21	90-066-05	2	PIN, 5/16 X 1/2 DOWEL
22	90-144-52	4	SSS, 10-32 X 1/4 SS18-8 CP
23	90-151-05	5	HFCS, 1/4-20 X 1/2 SS18-8
24	90-153-05	15	HFCS, 1/4-20 X 1/2 SS18-8
25	90-154-07	2	SSS, 1/4-20 X 3/4 SS18-8
26	90-155-52	1	WASHER, 1/4 SPLIT RING SS18-8
27	90-155-56	2	WASHER, #12 FLAT SS18-8
28	90-161-07	12	HFCS, 5/16-18 X 5/8 SS18-8
29	90-171-06	4	HFCS, 3/8-16 X 5/8 SS18-8
30	90-175-51	4	WASHER, 3/8 FLAT SS18-8
31	90-175-53	4	WASHER, SHOCKPROOF FINI., SS18-8
32	90-190-17	8	SHCS, 1/2-13 X 1-3/4 SS18-8
33	90-400-02	1	LABEL, WACHS CIRCLE LOGO 3.00
34	90-900-01	1	LABEL, READ MANUAL .75 DIA.
35	90-900-53	3	HANDLE, 6-1/2 X 1-3/4

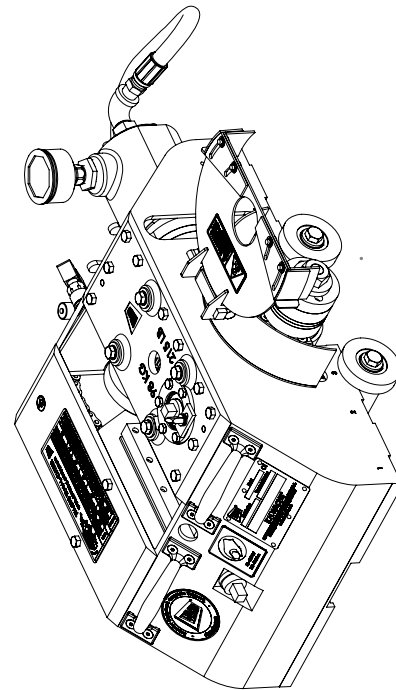



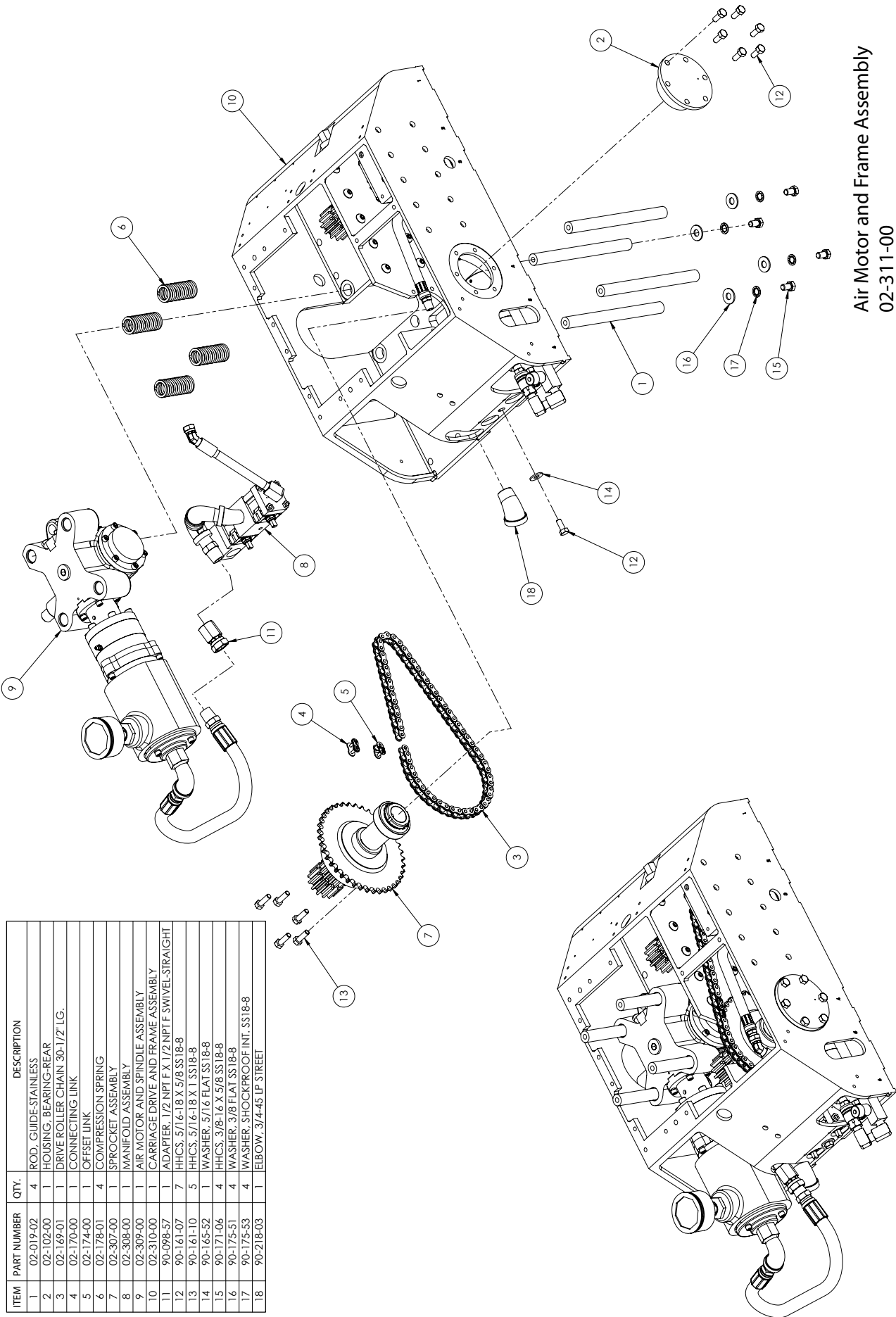

Air Motor and Frame Assembly  
02-311-00

ITEM	PART NUMBER	QTY.	DESCRIPTION
1	02-019-02	4	ROD, GUIDE-STAINLESS
2	02-102-00	1	HOUSING, BEARING-REAR
3	02-169-01	1	DRIVE ROLLER CHAIN 30-1/2" LG.
4	02-170-00	1	CONNECTING LINK
5	02-174-00	1	OFFSET LINK
6	02-178-01	4	COMPRESSION SPRING
7	02-307-00	1	SPROCKET ASSEMBLY
8	02-308-00	1	MANIFOLD ASSEMBLY
9	02-309-00	1	AIR MOTOR AND SPINDLE ASSEMBLY
10	02-310-00	1	CARRIAGE DRIVE AND FRAME ASSEMBLY
11	90-098-57	1	ADAPTER, 1/2 NPT F X 1/2 NPT F SWIVEL-STRAIGHT
12	90-161-07	7	HHCS, 5/16-18 X 5/8 SS 18-8
13	90-161-10	5	HHCS, 5/16-18 X 1 SS18-8
14	90-165-52	1	WASHER, 5/16 FLAT SS18-8
15	90-171-06	4	HHCS, 3/8-16 X 5/8 SS18-8
16	90-175-51	4	WASHER, 3/8 FLAT SS18-8
17	90-175-53	4	WASHER, SHOCKPROOF INT. SS18-8
18	90-218-03	1	ELBOW, 3/4-45 LP STREET

ITEM	PART NUMBER	QTY.	DESCRIPTION
1	02-033-00	1	MANIFOLD, AIR
2	90-058-02	1	NIPPLE, 1/4 X 5 GALV LP
3	90-058-04	1	COUPLING, 1/4 GALV LP
4	90-058-05	1	1/4 NPT F X 1/4 NPT M BRASS LP-90
5	90-058-51	1	ADAPTER, 1/4 NPT M X 1/4 NPT F SWIVEL-45
6	90-098-01	1	NIPPLE, 1/2 CLOSE LP BLACK
7	90-098-04	1	ELBOW, 1/2-45 STREET
8	90-098-05	1	ELBOW, 1/2-90 STREET
9	90-098-06	1	ELBOW, 1/2-90 LP
10	90-098-58	1	1/2 HEX HP NIPPLE

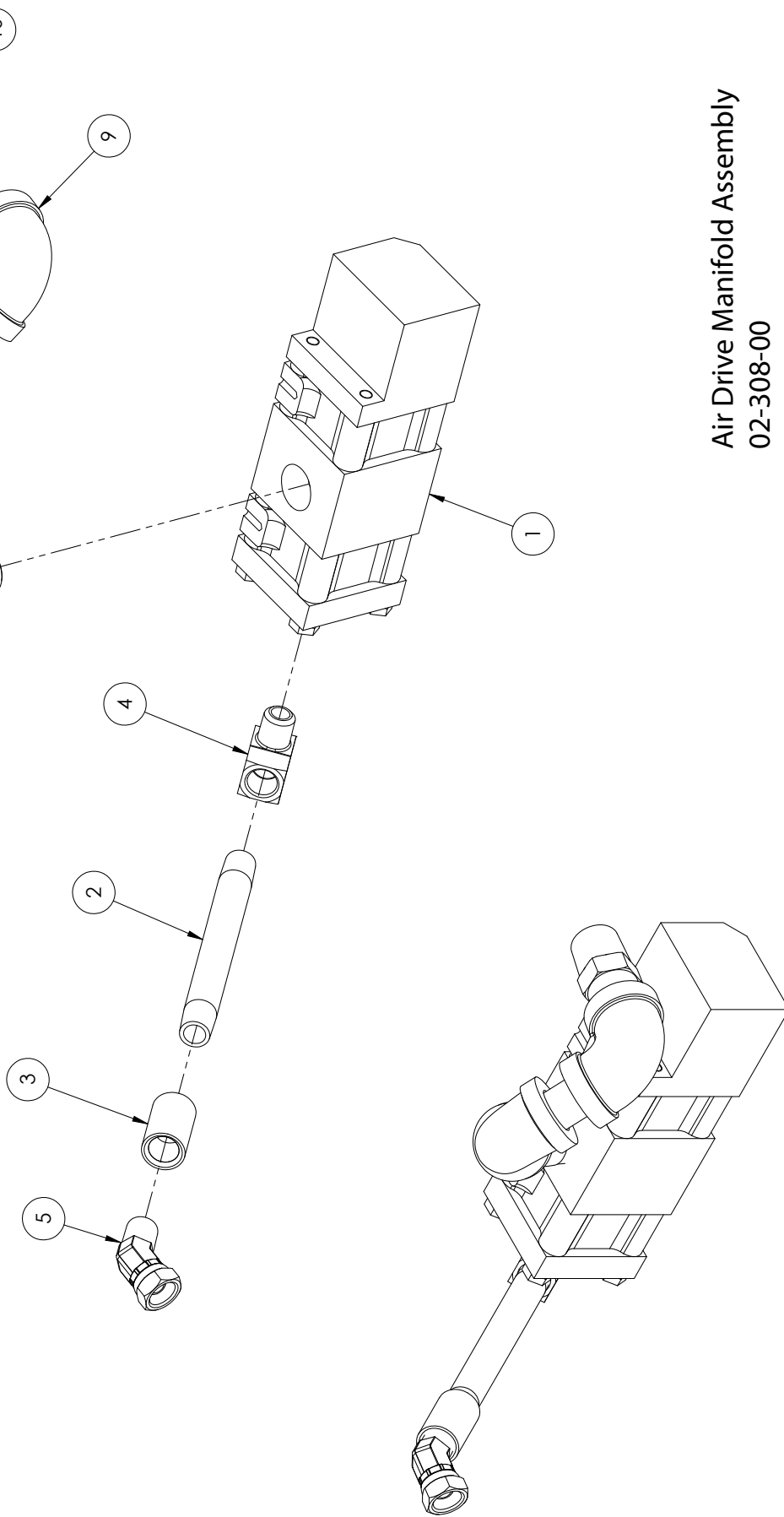

Air Drive Manifold Assembly  
02-308-00

ITEM	PART NUMBER	QTY.	DESCRIPTION
1	02-020-00	1	CUTTER SPINDLE GEAR ASSEMBLY
2	02-027-01	1	HOSE, 1/2" HP X 30" LONG
3	02-029-00	1	AIR MOTOR SUB-ASSEMBLY
4	90-150-08	5	SHCS, 1/4-20 X 7/8 SS18-8
5	90-155-51	5	WASHER, 1/4" HI COLLAR SS18-8

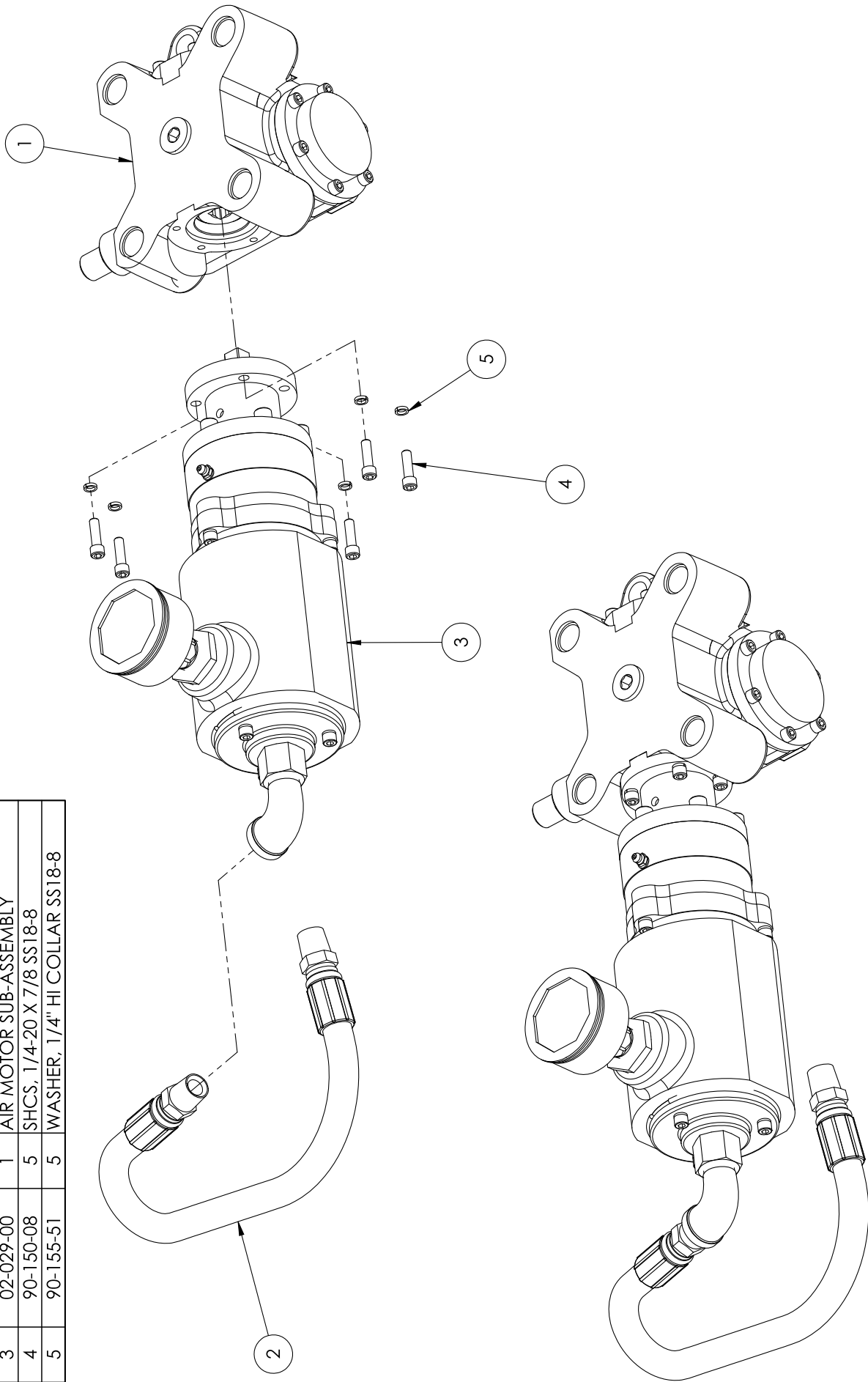

ITEM	PART NUMBER	QTY.	DESCRIPTION
1	02-081-01	1	SCREW, CHAIN TENSION
2	02-082-01	1	THRUST WASHER
3	02-083-00	1	PLATE, GIB BACKING
4	02-085-01	2	GIB, CHAIN TENSIONING
5	02-094-01	1	NUT, LOCK-CHAIN TEN. SCREW
6	02-131-00	1	SHAFT, GUIDE ROLLER-INSIDE
7	02-132-01	1	ROLLER, CHAIN GUIDE
8	02-133-00	2	BUSHING
9	02-137-02	1	CARRIAGE, UNIVERSAL
10	02-191-00	1	SHIM, GEAR BOX
11	02-301-00	1	CARRIAGE DRIVE ASSEMBLY
12	02-306-00	1	SLIDE AND SPROCKET ASSEMBLY
13	90-153-10	4	FHCS. 1/4-20 X 1" SS18-8
14	90-161-10	2	FHCS. 5/16-18 X 1 SS18-8
15	90-164-03	1	SSS. 5/16-18 X 3/8 SS18-8
16	90-172-10	10	BHCS. 3/8-16 X 1" SS18-8

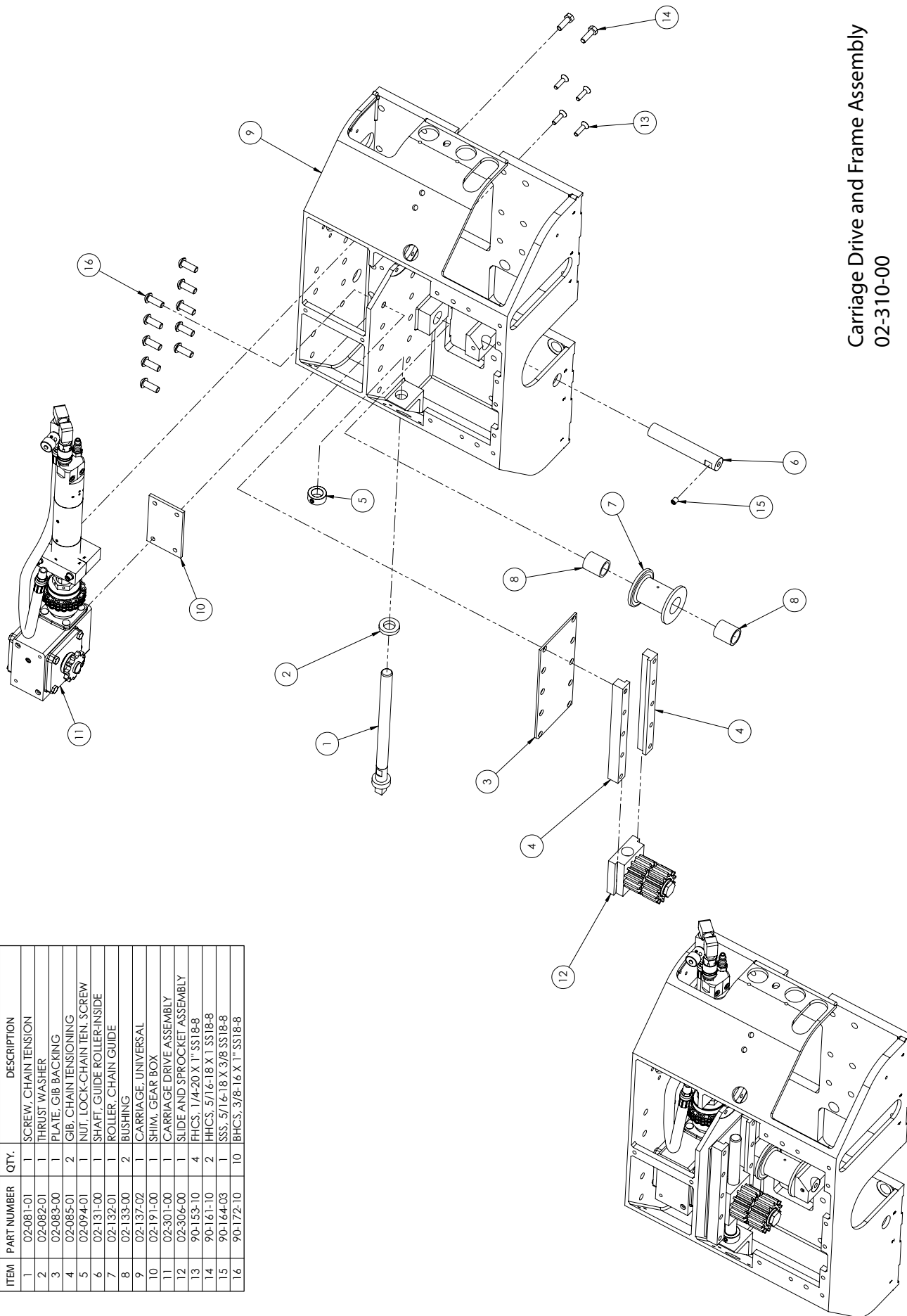

Carriage Drive and Frame Assembly  
02-310-00

Carriage Drive Assembly  
02-301-00

ITEM	PART NUMBER	QTY.	DESCRIPTION
1	02-031-00	1	HOSE, TRAVEL MOTOR
2	02-035-00	1	MOTOR, TRAVEL-AIR
3	02-037-00	1	CLAMP, AIR MOTOR
4	02-043-00	1	OVERLOAD SAFETY COUPLING
5	02-108-00	1	SPROCKET, DRIVE
6	02-194-00	1	GEAR BOX, CARRIAGE DRIVE
7	02-212-00	1	FLOW CONTROL VALVE 1/4"
8	90-027-12	1	KEY, 1/8 SQ X 1-1/4
9	90-044-52	1	SSS, 10-32 X 1/4 CP
10	90-047-05	1	KEY, 3/16 SQ. X 1/2
11	90-058-05	2	1/4 NPT F X 1/4 NPT M BRASS LP-90
12	90-059-51	1	DISCONNECT, FEMALE 1/4 NPT M
13	90-059-53	2	DISCONNECT, MALE 1/4 NPT M

NOTES:  
1. AIR MOTOR WOODRUFF KEY REPLACEMENT  
PART NO.: 90-029-44

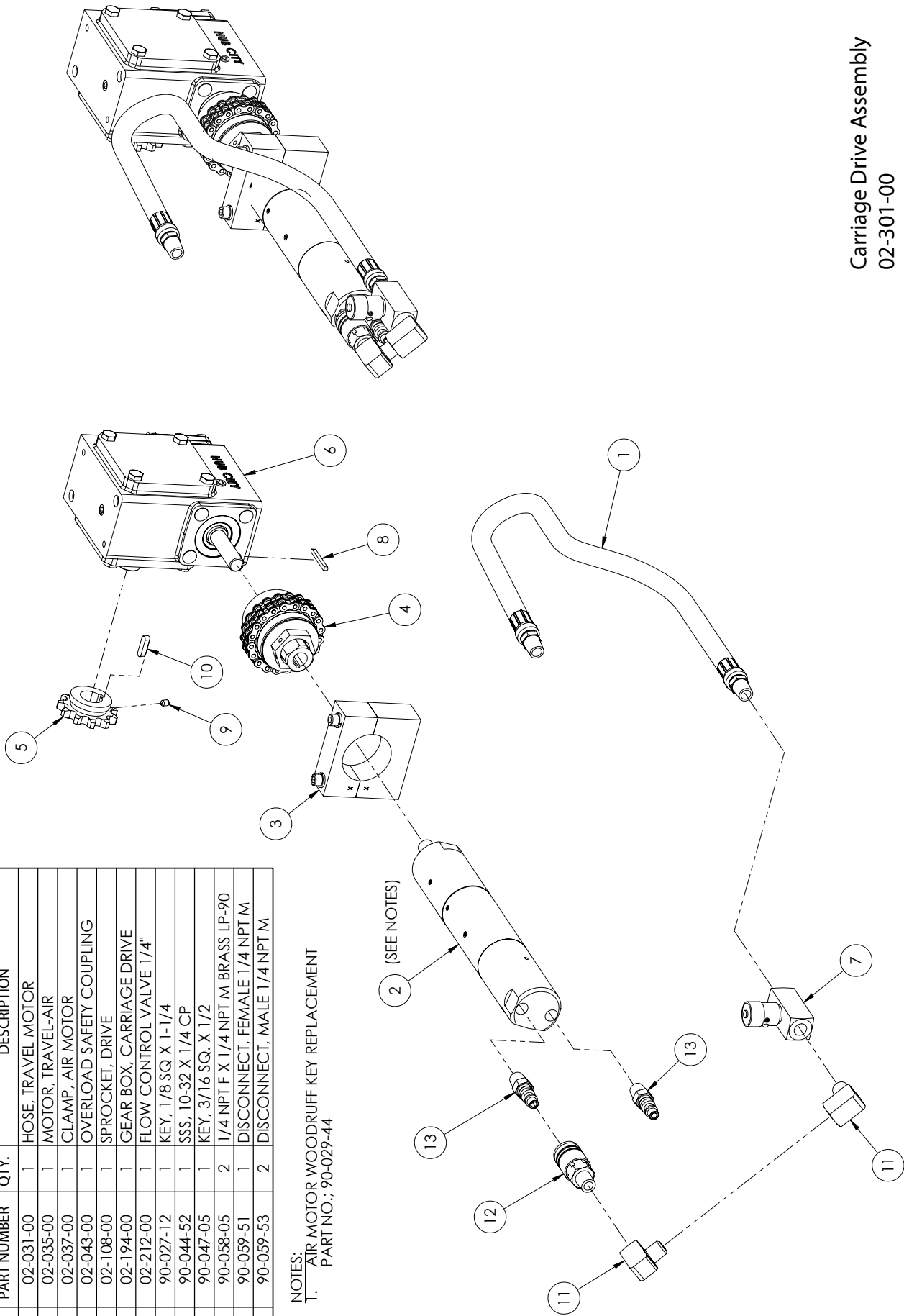

ITEM	PART NUMBER	QTY.	DESCRIPTION
1	02-030-00	1	AIR MOTOR
2	02-199-00	1	MOTOR COUPLING, DRIVE PIN
3	02-203-00	1	MOTOR COUPLING, CUTTER SPINDLE
4	02-252-00	1	ADAPTER, MOTOR-TRV-L-CUTTER (L.R. 4800P)
5	23-181-00	1	MUFFLER
6	90-057-13	1	KEY, 1/4 SQ. X 1-3/8
7	90-098-05	1	ELBOW, 1/2 X 1
8	90-098-75	1	BUSHING, 1/2 X 1 REDUCING
9	90-154-02	1	SSS, 1/4-20 X 1/4 SS18-8
10	90-160-08	6	SHCS, 5/16-18 X 7/8 SS18-8

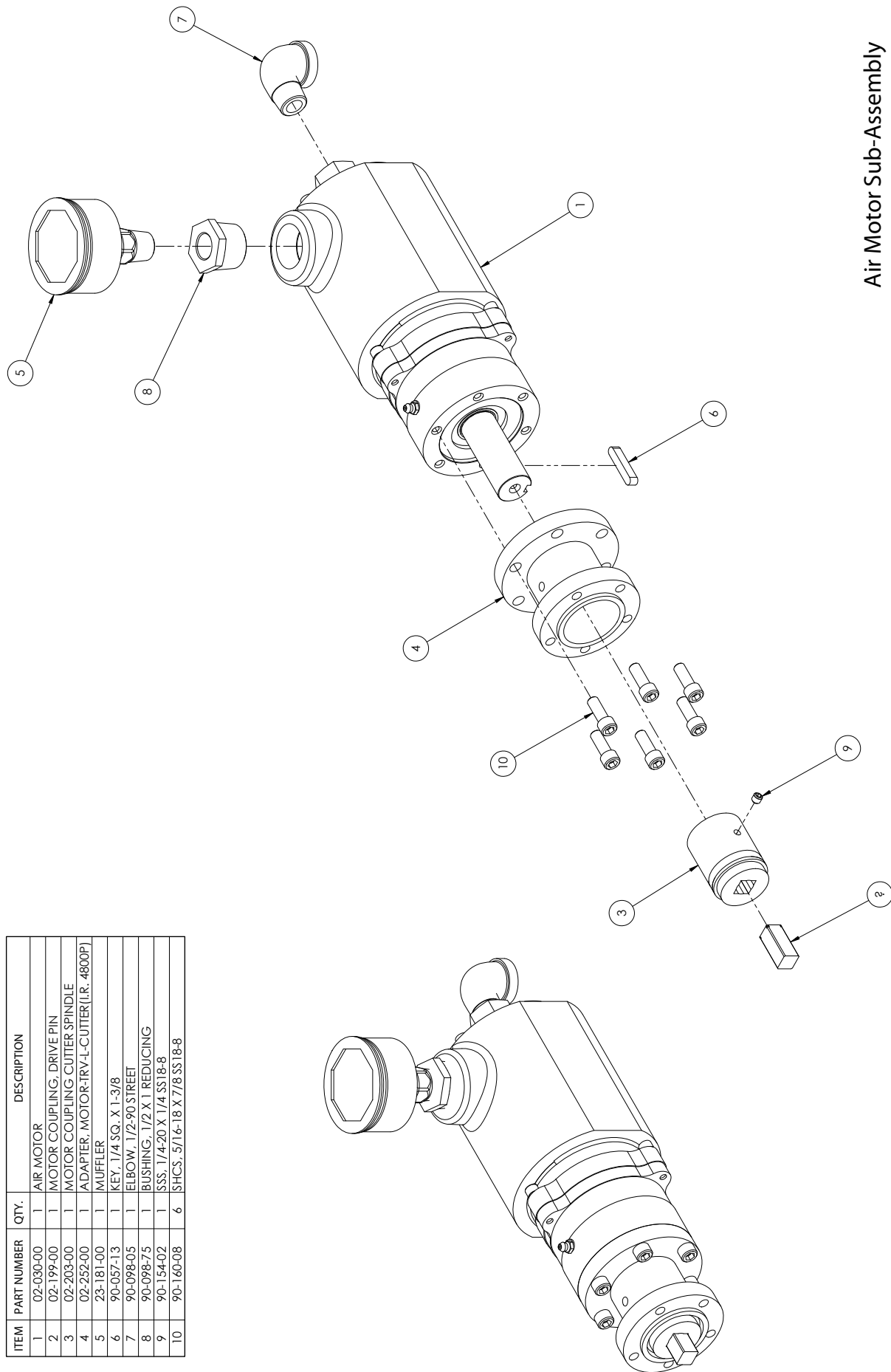

Air Motor Sub-Assembly  
02-029-00

ITEM	PART NUMBER	QTY	DESCRIPTION
1	02-113-00	1	PLATE, END
2	02-114-00	2	VALVE, AIR
3	02-115-00	1	BLOCK, INTERMEDIATE
4	02-117-00	1	BLOCK, AIR INLET
5	90-050-45	4	SHCS, 1/4-28 X 4-1/2
6	90-075-04	2	NUT, 3/8-24 NYLOCK THN.
7	90-075-54	2	WASHER, 3/8 AN

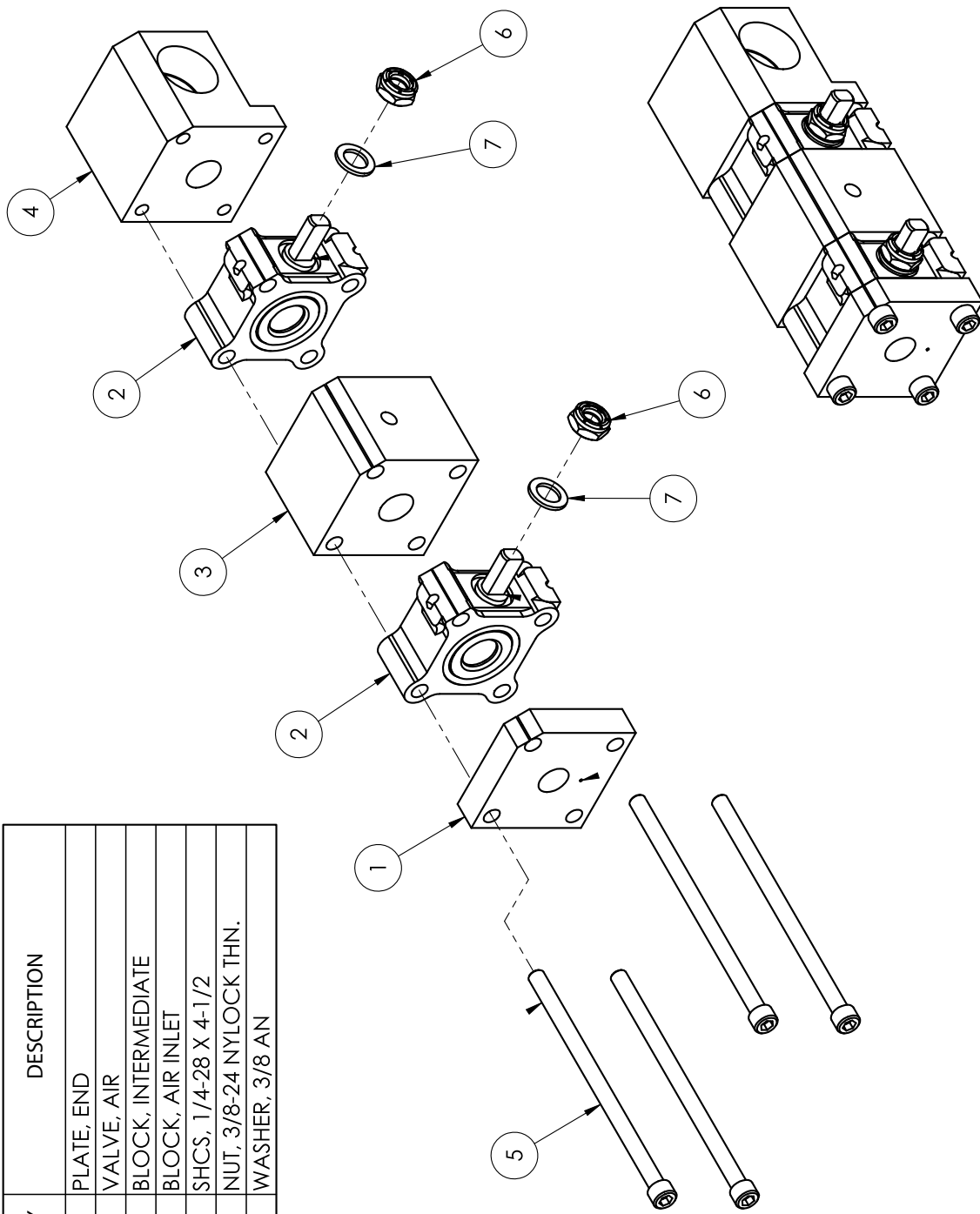

ITEM	PART NUMBER	QTY.	DESCRIPTION
1	02-125-00	1	LABEL-SCALE, CHAIN LENGTH (NOT SHOWN)
2	02-155-00	1	STEEL CABLE (NOT SHOWN)
3	02-158-00	5	CONNECTING PIN FOR CHAIN
4	02-159-00	1	LINE-UP PIN (NOT SHOWN)
5	02-162-00	1	WRENCH, TORQUE (NOT SHOWN)
6	02-175-00	3	STEEL WEDGE (NOT SHOWN)
7	02-176-00	1	STORAGE CASE (NOT SHOWN)
8	02-177-00	1	CASE/DIVIDER FOR BLADES (NOT SHOWN)
9	02-287-00	1	WHEEL SETTING CHART (NOT SHOWN)
10	02-289-00	1	CHAIN LENGTHS CHART (NOT SHOWN)
11	02-318-00	1	HYDRAULIC CARRIAGE ASSEMBLY
12	02-319-00	1	LABEL, CASE-TRAV "L" (NOT SHOWN)
13	02-450-48	1	SILENT CHAIN
14	02-LIT-01	1	TOOLING CHART, TRAV-L (NOT SHOWN)
15	02-MAN-01	1	MANUAL (NOT SHOWN)
16	90-800-01	1	WRENCH, 1-1/4 OPEN END (NOT SHOWN)
17	90-800-05	1	WRENCH, 1/2 DRV. BREAKER BAR (NOT SHOWN)
18	90-800-10	1	WRENCH, 3/8 HEX LONG ARM (NOT SHOWN)
19	90-800-11	2	SOCKET, 1/2 DRV. X 1/2 8PT. IMPACT (NOT SHOWN)

CONNECTING PIN (02-158-00) QTY. (5) SHIPPED LOOSE WITH ASSEMBLY.

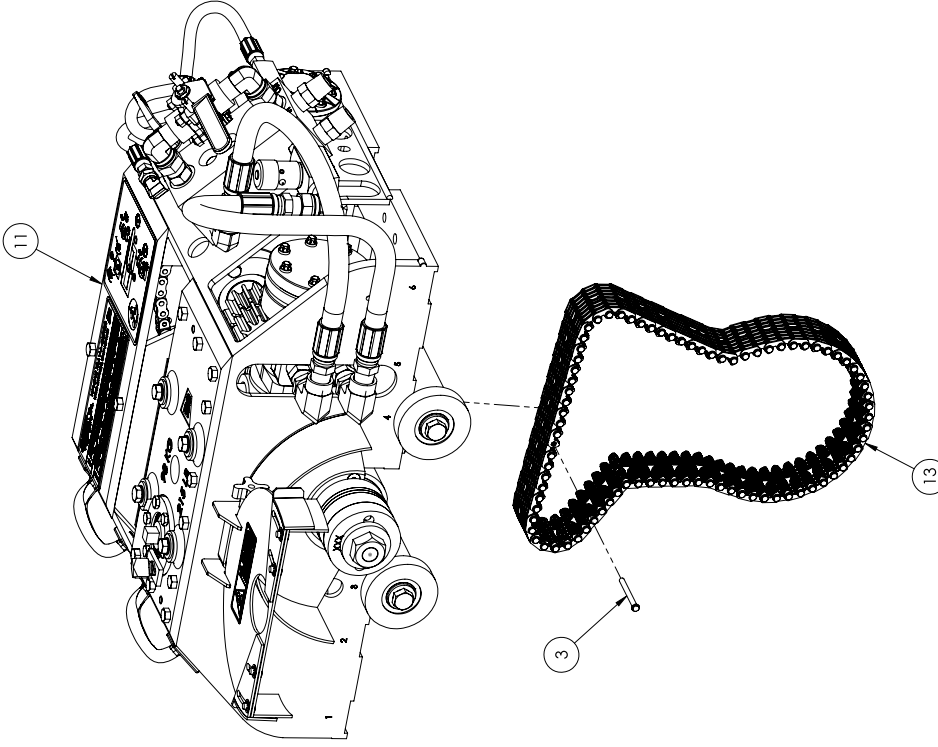

Trav-L-Cutter Assembly, Hydraulic Drive  
02-000-02

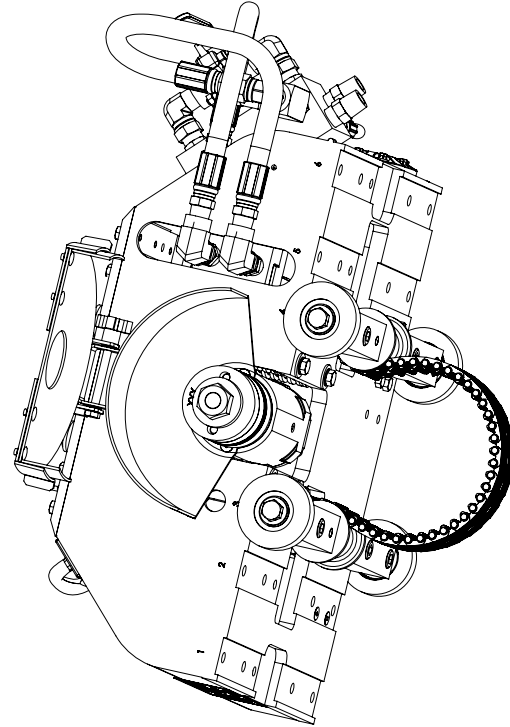



Hydraulic Carriage Assembly  
02-318-00

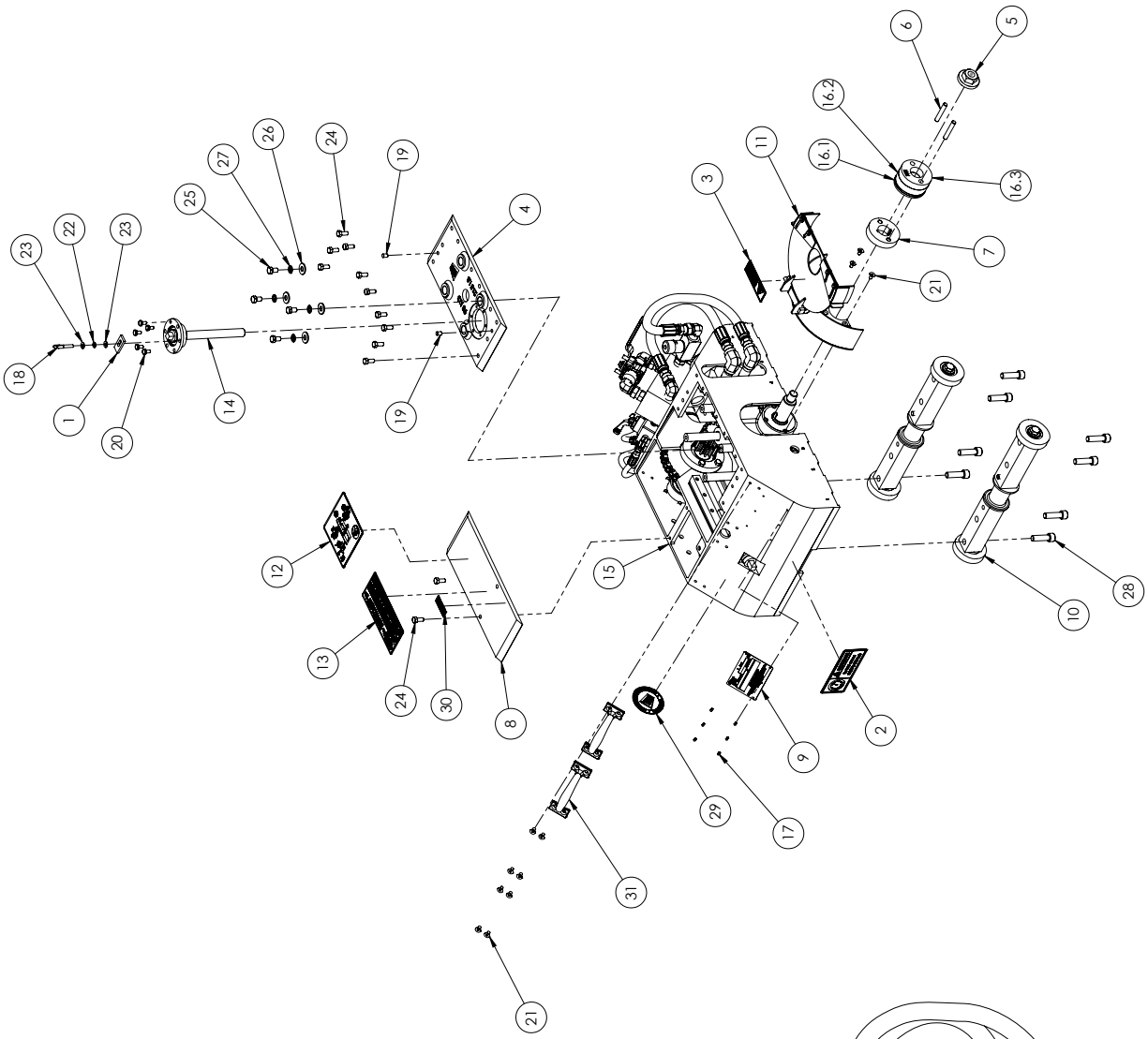

ITEM	PART NUMBER	QTY.	DESCRIPTION
1	02-008-00	1	LOCK, FEED SCREW
2	02-009-00	1	LABEL, PRESSURE-HYD.
3	02-011-00	1	LABEL, WARNING-BLADE GUARD
4	02-013-00	1	COVER, SPINDLE CARRIAGE
5	02-014-00	1	LOCK NUT, DRIVE COLLAR
6	02-021-01	2	PIN, CUTTER DRIVE
7	02-022-01	1	COLLAR, CUTTER DRIVE
8	02-135-00	1	COVER, DRIVE SIDE
9	02-141-00	1	PLATE, NAME
10	02-142-00	2	WHEEL ASSEMBLY
11	02-179-00	1	CUTTER GUARD ASSEMBLY
12	02-298-00	1	LABEL, TRAV-L-CUTTER HYD.
13	02-300-00	1	MACHINE CHAIN & WHEEL CHART
14	02-304-00	1	FEED SCREW ASSEMBLY
15	02-317-00	1	HYD. MOTOR AND FRAME ASSEMBLY
16	02-500-03	1	KIT, CUTTER SPACERS, 3/16, 1/16, & 3/4
16.1	02-290-03	2	SPACER, TRAV-L-CUTTER
16.2	02-290-17	1	SPACER, TRAV-L-CUTTER
16.3	02-290-20	1	SPACER, TRAV-L-CUTTER
17	90-048-01	6	SCREW, #4 X 1/4 ROUND U-DRIVE SS18-8
18	90-059-04	1	SCREW, 1/4-20 X 1-1/4 THUMB
19	90-066-05	2	PIN, 5/16 X 1/2 DOWEL
20	90-151-05	5	HHCS, 1/4-20 X 1/2 SS18-8
21	90-153-05	11	FHCS, 1/4-20 X 1/2 SS18-8
22	90-155-52	1	WASHER, 1/4 SPLIT RING SS18-8
23	90-155-56	2	WASHER, #12 FLAT SS18-8
24	90-161-07	12	HHCS, 5/16-18 X 5/8 SS18-8
25	90-171-06	4	HHCS, 3/8-16 X 5/8 SS18-8
26	90-175-51	4	WASHER, 3/8 FLAT SS18-8
27	90-175-53	4	WASHER, SHOCKPROOF INT. SS18-8
28	90-190-17	8	SHCS, 1/2-13 X 1-3/4 SS18-8
29	90-400-02	1	LABEL, WACHS CIRCLE LOGO 3.00
30	90-900-01	1	LABEL, MANUAL
31	90-900-53	2	HANDLE, 6-1/2 X 1-3/4

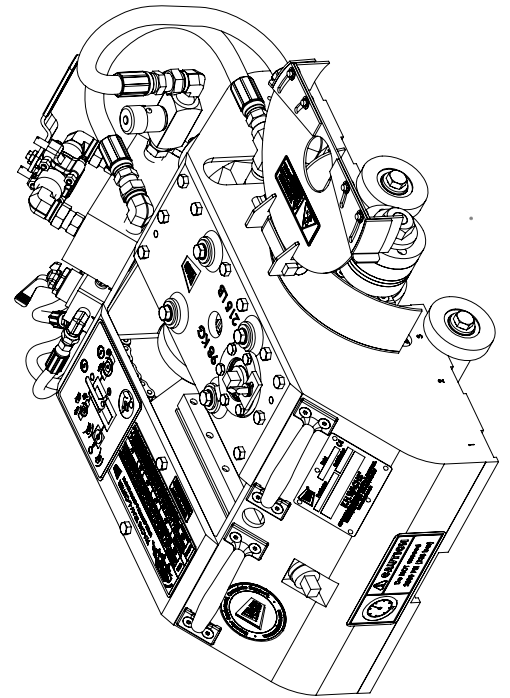

ITEM	PART NUMBER	QTY.	DESCRIPTION
1	02-019-02	4	ROD, GUIDE/STAINLESS
2	02-102-00	1	HOUSING, BEARING-REAR
3	02-169-01	1	DRIVE ROLLER CHAIN 30-1/2" LG.
4	02-170-00	1	CONNECTING LINK
5	02-174-00	1	OFFSET LINK
6	02-178-01	4	COMPRESSION SPRING
7	02-307-00	1	SPROCKET ASSEMBLY
8	02-314-00	1	HYD. CARRIAGE DRIVE AND FRAME ASSEMBLY
9	02-315-00	1	HYD. MANIFOLD ASSEMBLY
10	02-316-00	1	HYD. MOTOR AND SPINDLE ASSEMBLY
11	90-161-07	6	HHCS, 5/16-18 X 5/8 SS18-8
12	90-161-10	5	HHCS, 5/16-18 X 1 SS18-8
13	90-171-06	4	HHCS, 3/8-16 X 5/8 SS18-8
14	90-175-51	4	WASHER, 3/8 FLAT SS18-8
15	90-175-53	4	WASHER, SHOCKPROOF INT. SS18-8

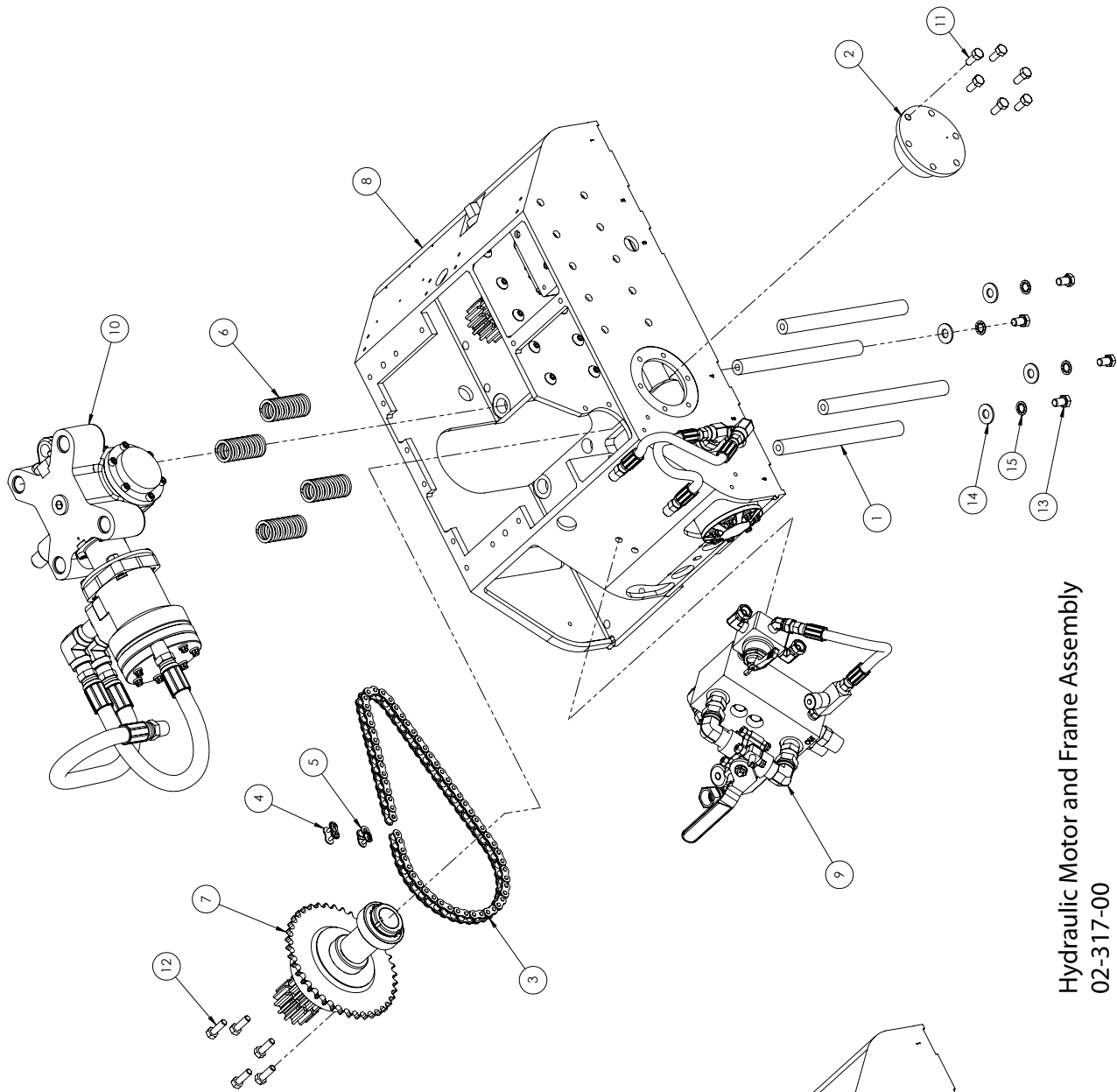

Hydraulic Motor and Frame Assembly  
02-317-00

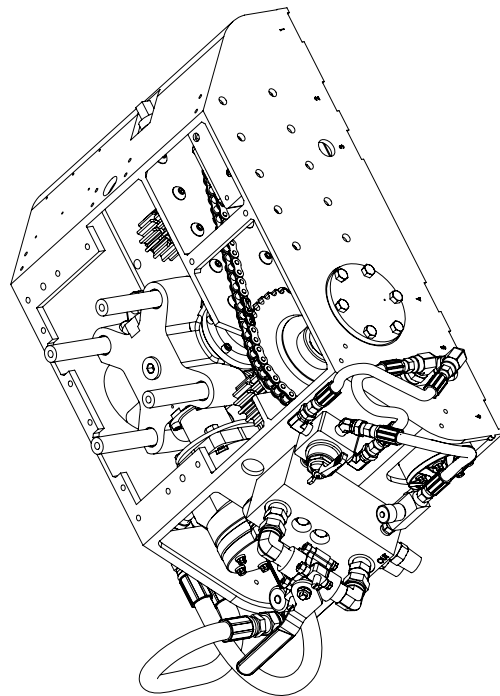

ITEM	PART NUMBER	QTY.	DESCRIPTION
1	02-081-01	1	SCREW, CHAIN TENSION
2	02-082-01	1	THRUST WASHER
3	02-083-00	1	PLATE, GIB BACKING
4	02-085-01	2	GIB, CHAIN TENSIONING
5	02-094-01	1	NUT, LOCK-CHAIN TEN. SCREW
6	02-131-00	1	SHAFT, GUIDE ROLLER-INSIDE
7	02-132-01	1	ROLLER, CHAIN GUIDE
8	02-133-00	2	BUSHING
9	02-137-02	1	CARRIAGE, UNIVERSAL
10	02-206-01	1	SHIM, HYDRAULIC GEAR BOX
11	02-306-00	1	SLIDE AND SPROCKET ASSEMBLY
12	02-313-00	1	HYD. CARRIAGE DRIVE ASSEMBLY
13	90-153-12	4	FHC.S. 1/4-20 X 1-1/4 SS18-8
14	90-161-10	4	FHC.S. 5/16-18 X 1 SS18-8
15	90-164-03	1	SSS. 5/16-18 X 3/8 SS18-8
16	90-172-10	10	BHCS. 3/8-16 X 1" SS18-8

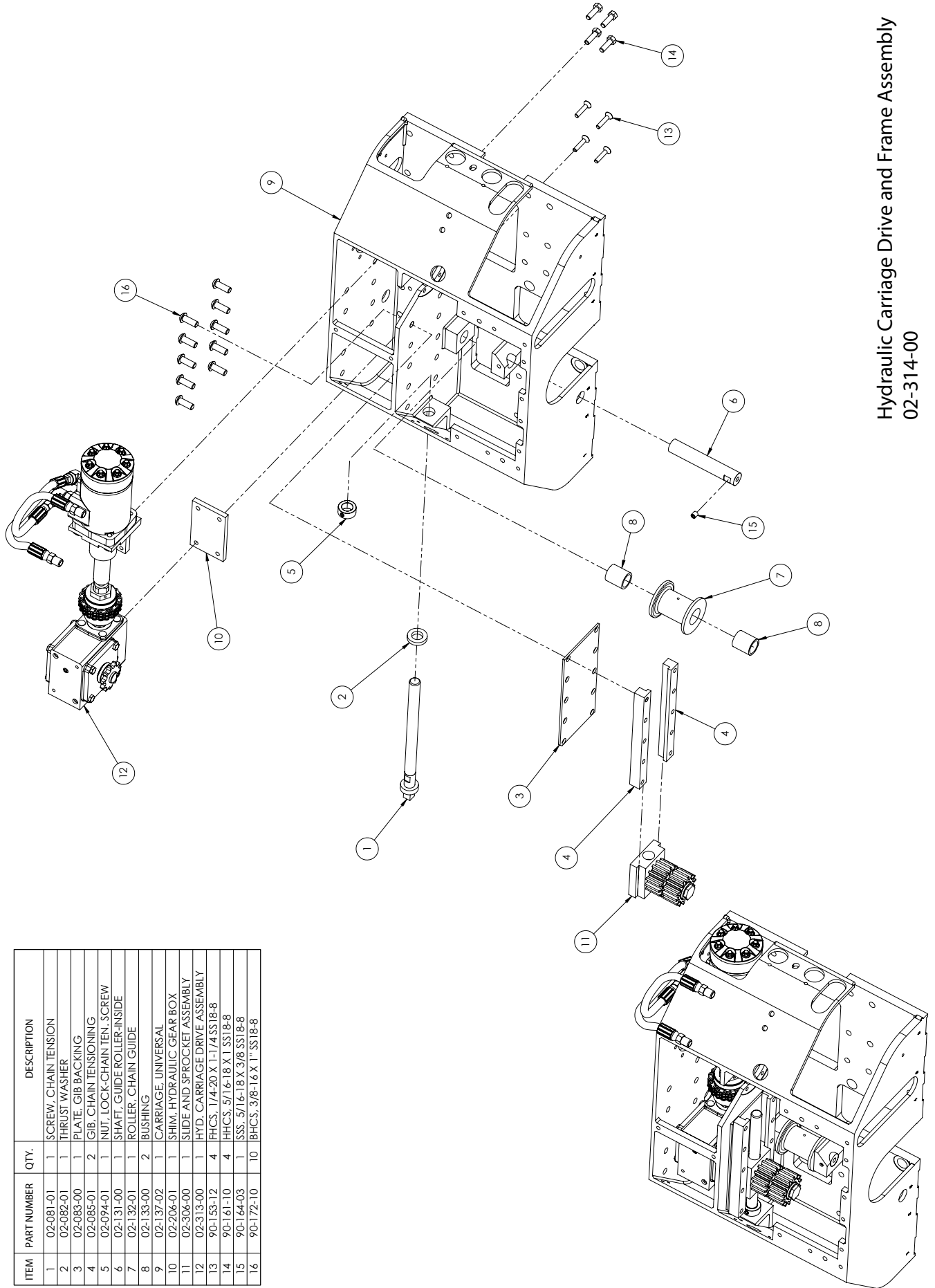

Hydraulic Carriage Drive and Frame Assembly  
02-314-00

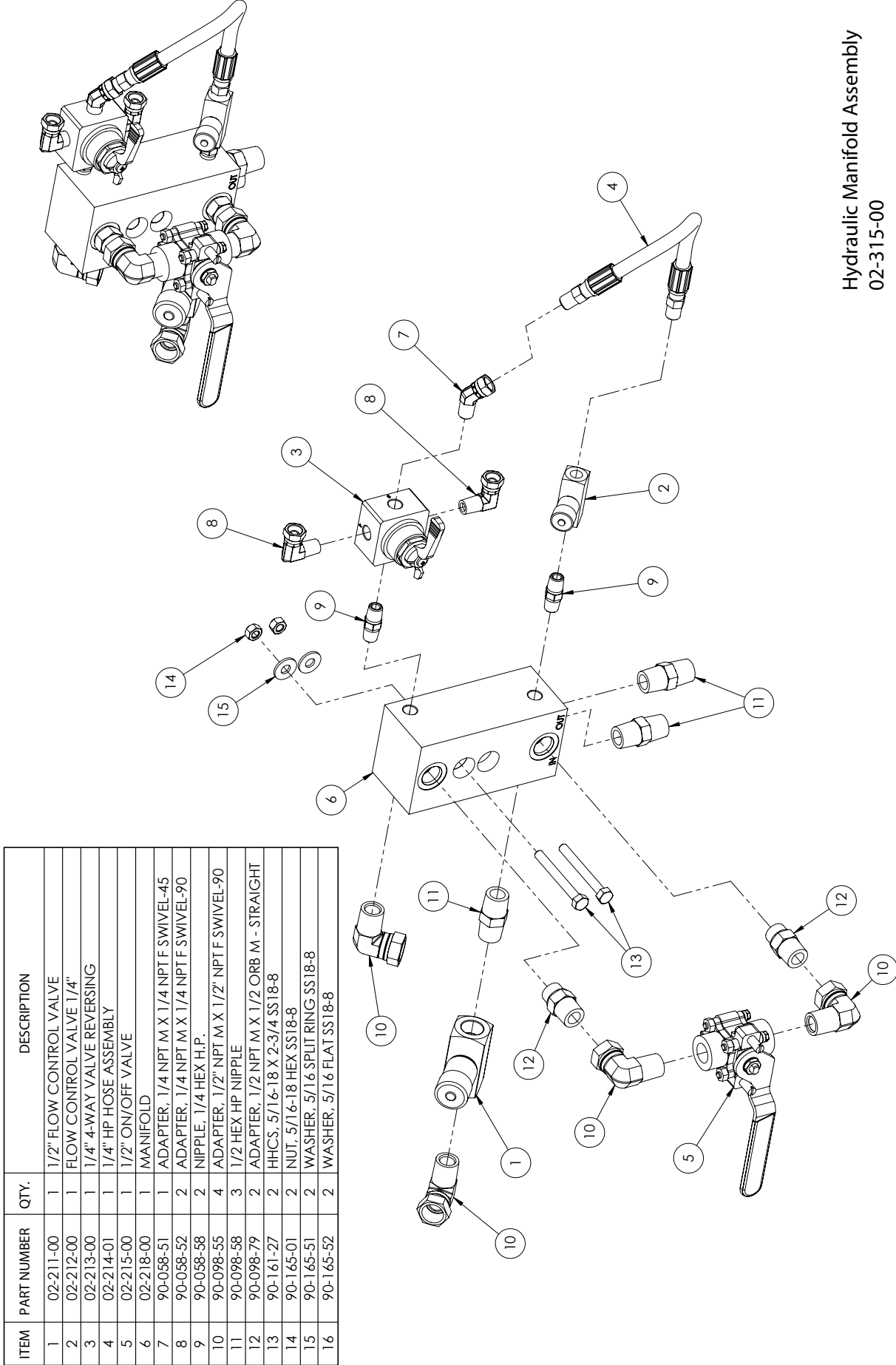

Hydraulic Manifold Assembly  
02-315-00

ITEM	PART NUMBER	QTY.	DESCRIPTION
1	02-211-00	1	1/2" FLOW CONTROL VALVE
2	02-212-00	1	FLOW CONTROL VALVE 1/4"
3	02-213-00	1	1/4" 4-WAY VALVE REVERSING
4	02-214-01	1	1/4" HP HOSE ASSEMBLY
5	02-215-00	1	1/2" ON/OFF VALVE
6	02-218-00	1	MANIFOLD
7	90-058-51	1	ADAPTER, 1/4 NPT M X 1/4 NPT F SWIVEL-45
8	90-058-52	2	ADAPTER, 1/4 NPT M X 1/4 NPT F SWIVEL-90
9	90-058-58	2	NIPPLE, 1/4 HEX H.P.
10	90-098-55	4	ADAPTER, 1/2" NPT M X 1/2" NPT F SWIVEL-90
11	90-098-58	3	1/2 HEX HP NIPPLE
12	90-098-79	2	ADAPTER, 1/2 NPT M X 1/2 ORB M - STRAIGHT
13	90-161-27	2	HHCS, 5/16-18 X 2-3/4 SS18-8
14	90-165-01	2	NUT, 5/16-18 HEX SS18-8
15	90-165-51	2	WASHER, 5/16 SPLIT RING SS18-8
16	90-165-52	2	WASHER, 5/16 FLAT SS18-8

ITEM	PART NUMBER	QTY.	DESCRIPTION
1	02-020-00	1	CUTTER SPINDLE GEAR ASSEMBLY
2	02-027-01	2	HOSE, 1/2" HP X 30" LONG
3	02-199-00	1	MOTOR COUPLING, DRIVE PIN
4	02-201-00	1	HYDRAULIC MOTOR, CUTTER SPINDLE
5	02-202-00	1	ADAPTER, CUTTER SPINDLE MOTOR
6	02-203-00	1	ADAPTOR, DRIVE MOTOR
7	90-098-58	2	1/2 HEX HP NIPPLE
8	90-098-64	2	ADAPTER, 1/2" NPT F X 1/2" NPT F SWIVEL-90
9	90-150-07	5	SHCS, 1/4-20 X 3/4, SS18-8
10	90-155-51	5	WASHER, 1/4" HI-COLLAR SS18-8
11	90-171-07	4	HHCS, 3/8-16 X 3/4 SS18-8

HYDRAULIC MOTOR WOODRUFF KEY REPLACEMENT  
PART NO.: 90-059-48.

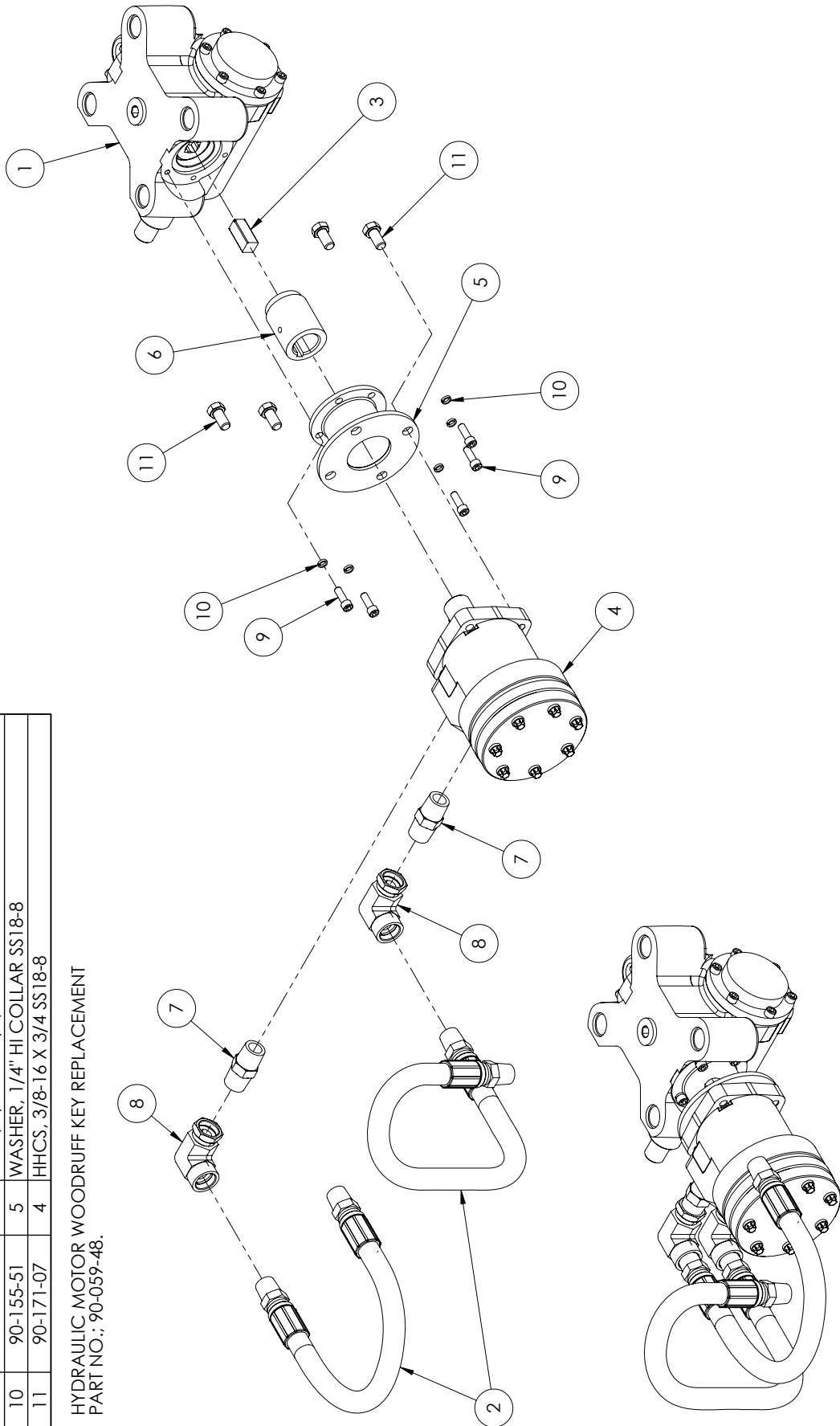

ITEM	PART NUMBER	QTY.	DESCRIPTION
1	02-043-00	1	OVERLOAD SAFETY COUPLING
2	02-108-00	1	SPROCKET, DRIVE
3	02-194-00	1	GEAR BOX, CARRIAGE DRIVE
4	02-200-00	1	HYDRAULIC MOTOR, CARRIAGE DRIVE
5	02-204-00	1	ADAPTER, (DRIVE MOTOR)
6	02-205-00	1	BRACKET, MOUNTING-DRIVE MOTOR
7	02-214-01	2	1/4" HP HOSE ASSEMBLY
8	90-027-12	1	KEY, 1/8 SQ X 1-1/4
9	90-029-44	1	KEY 1/8 X 1/2 #3 WOODRUFF (404)
10	90-044-52	1	SSS, 10-32 X 1/4 CP
11	90-047-05	1	KEY, 3/16 SQ. X 1/2
12	90-058-56	2	ELBOW, 1/4-90 HP STREET
13	90-058-57	2	BUSHING, 1/2 X 1/4 HP REDUCING
14	90-154-02	1	SSS, 1/4-20 X 1/4 SS18-8
15	90-171-08	4	HHCS, 3/8-16 X 7/8 SS18-8

NOTES:  
 1. HYDRAULIC MOTOR WOODRUFF KEY REPLACEMENT  
 PART NO.: 90-059-48

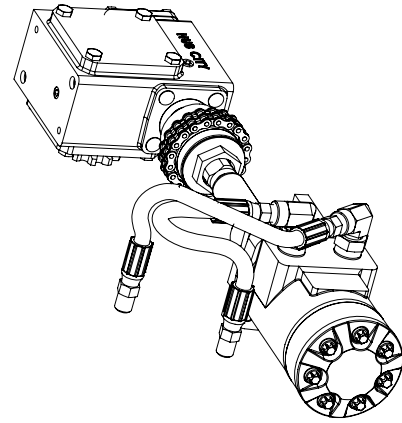
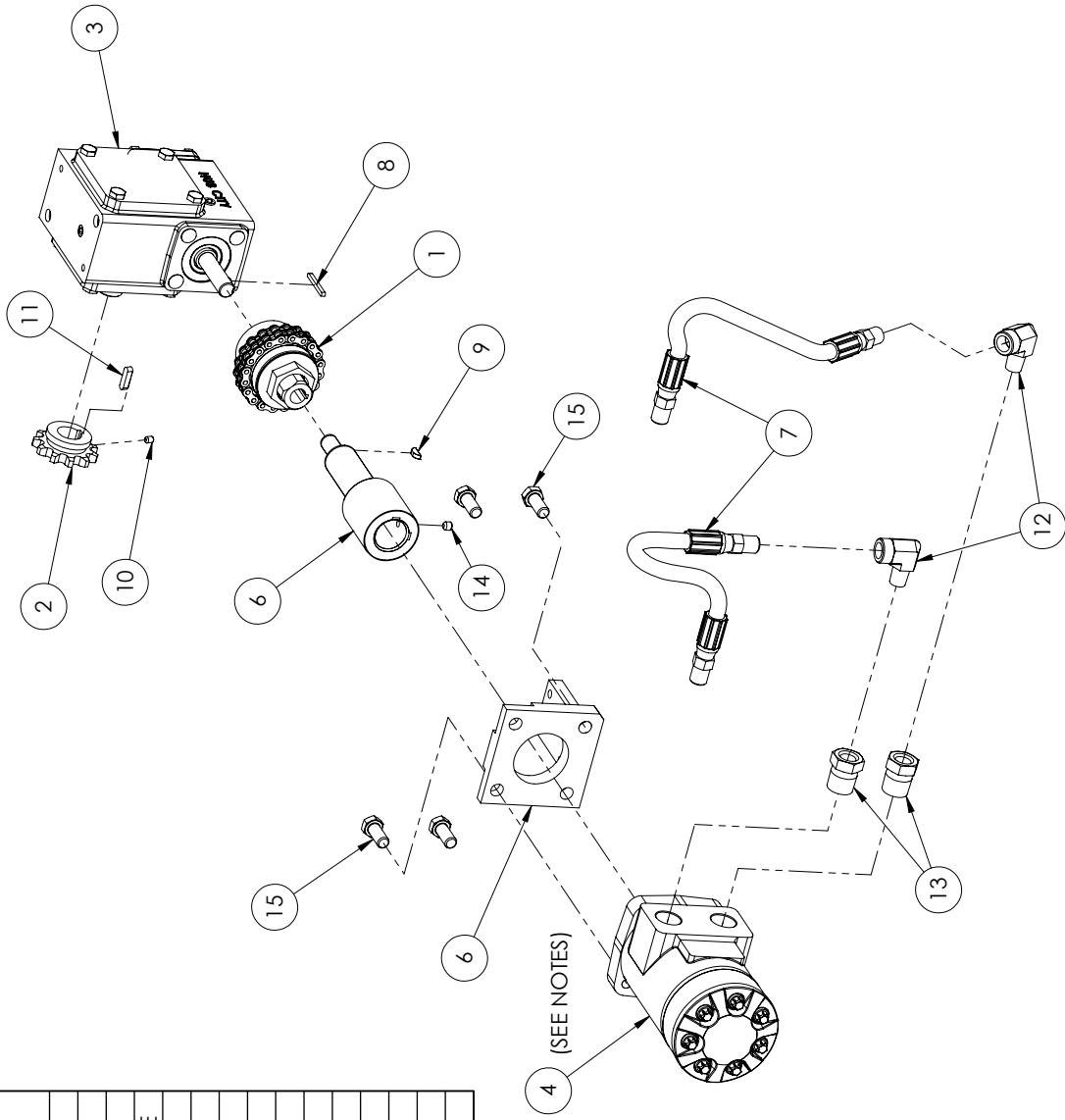

Hydraulic Carriage Drive Assembly  
 02-313-00

Wheel Assembly  
02-142-00

ITEM	PART NUMBER	QTY.	DESCRIPTION
1	02-002-00	2	RING, RETAINING
2	02-132-01	1	ROLLER, CHAIN GUIDE
3	02-133-00	2	BUSHING
4	02-144-00	1	AXLE
5	02-148-00	2	BRACKET, AXLE
6	02-151-00	2	BEARING, BALL
7	02-152-01	2	WHEEL
8	90-076-15	1	PIN, 3/8 X 1-1/2 DOWEL
9	90-076-20	1	PIN, 3/8 X 2 DOWEL
10	90-191-10	2	HHCS, 1/2-13 X 1.00 SS18-8
11	90-195-52	2	WASHER, 1/2 FLAT SS18-8

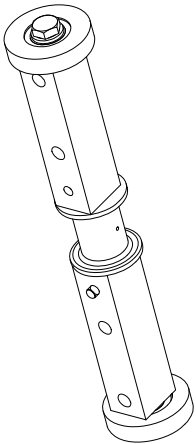
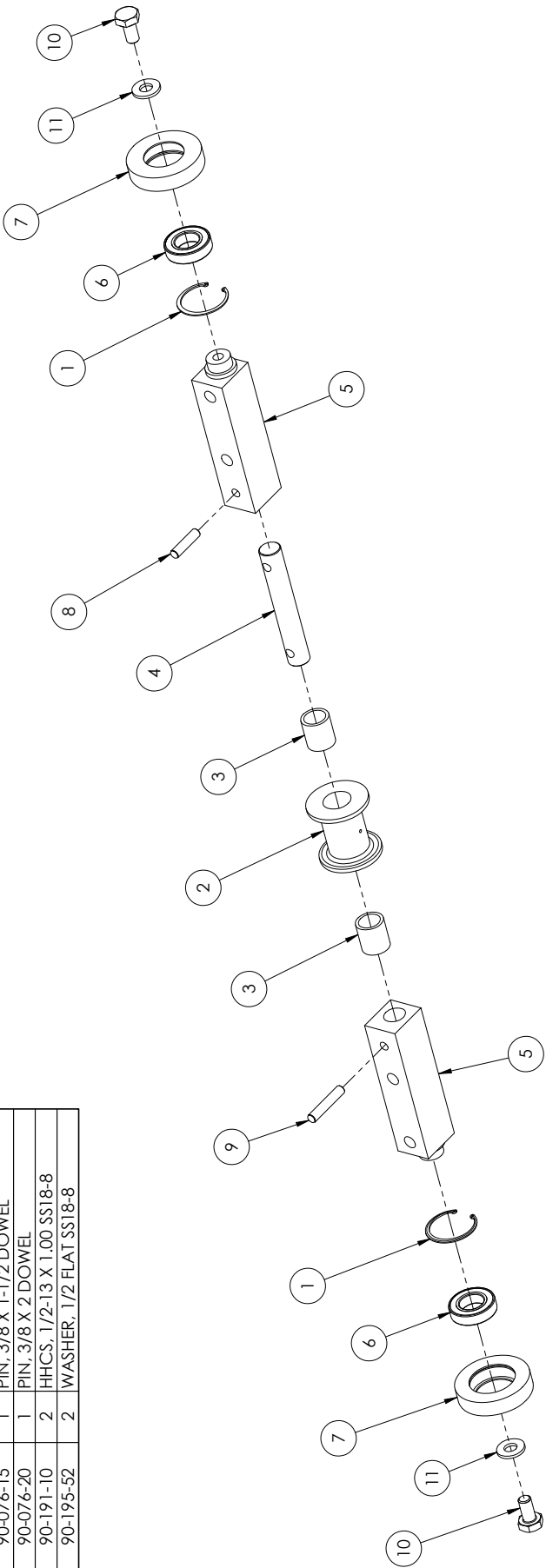

ITEM	PART NUMBER	QTY.	DESCRIPTION
1	02-001-00	1	SCREW, FEED
2	02-002-00	1	RING, RETAINING
3	02-003-00	1	BEARING, BALL
4	02-005-00	1	BEARING HOUSING, FEED SCREW
5	02-006-00	1	LOCK NUT, FEED SCREW BEARING

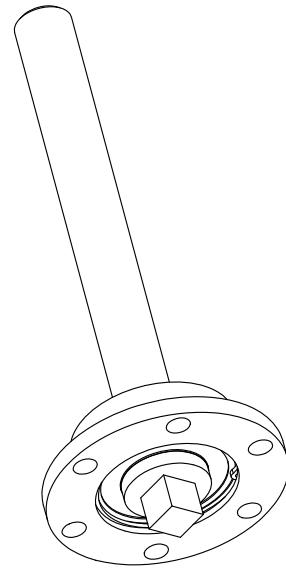
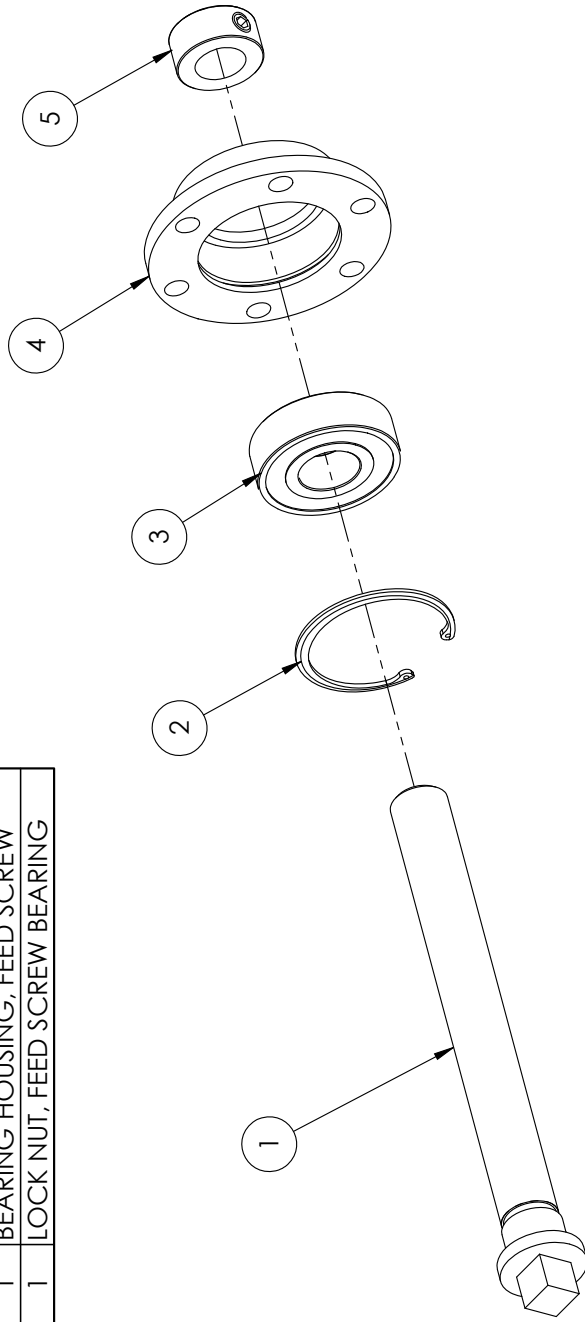

Feed Screw Assembly  
02-304-00



ITEM	PART NUMBER	QTY.	DESCRIPTION
1	02-004-00	1	BOLT, MODIFIED 1/2-13 X 1.00 SS
2	02-084-00	1	SLIDE, CHAIN TENSION SPROCKET
3	02-086-00	1	SPROCKET
4	02-087-00	1	BUSHING, TENSIONING SPROCKET
5	90-195-52	1	WASHER, 1/2 FLAT SS18-8

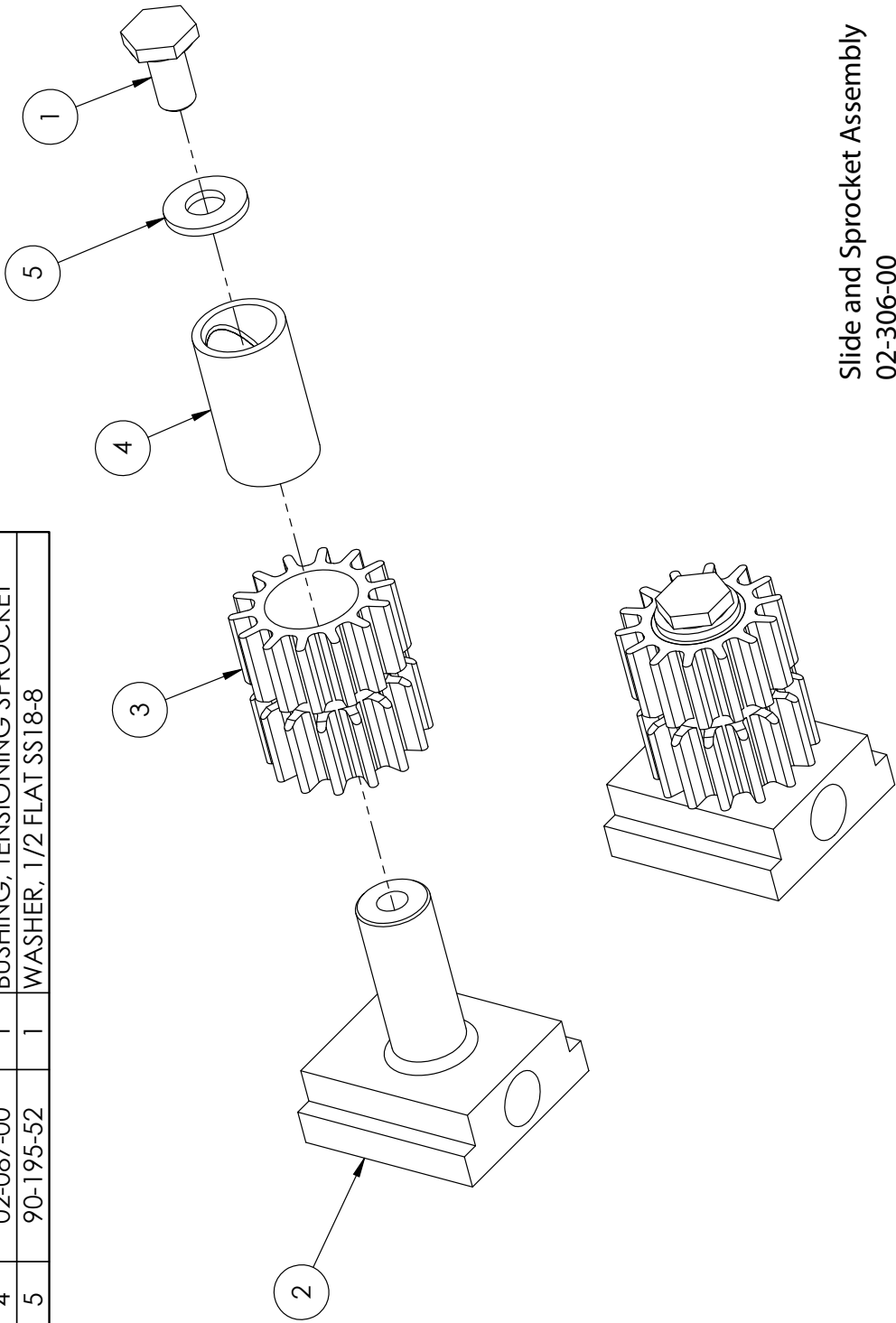

Slide and Sprocket Assembly  
02-306-00

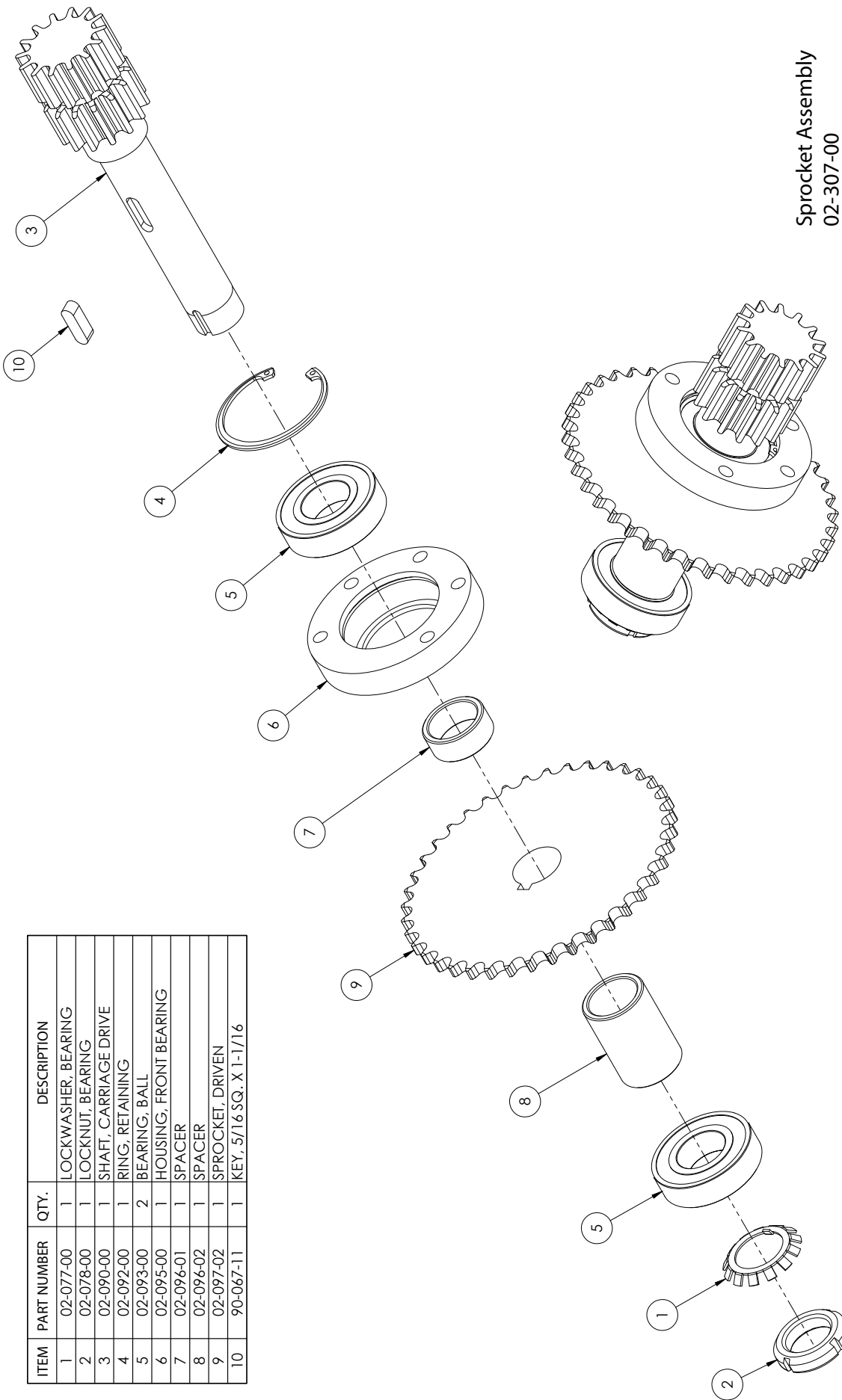

Sprocket Assembly  
02-307-00

ITEM	PART NUMBER	QTY.	DESCRIPTION
1	02-077-00	1	LOCKWASHER, BEARING
2	02-078-00	1	LOCKNUT, BEARING
3	02-090-00	1	SHAFT, CARRIAGE DRIVE
4	02-092-00	1	RING, RETAINING
5	02-093-00	2	BEARING, BALL
6	02-095-00	1	HOUSING, FRONT BEARING
7	02-096-01	1	SPACER
8	02-096-02	1	SPACER
9	02-097-02	1	SPROCKET, DRIVEN
10	90-067-11	1	KEY, 5/16 SQ. X 1-1/16

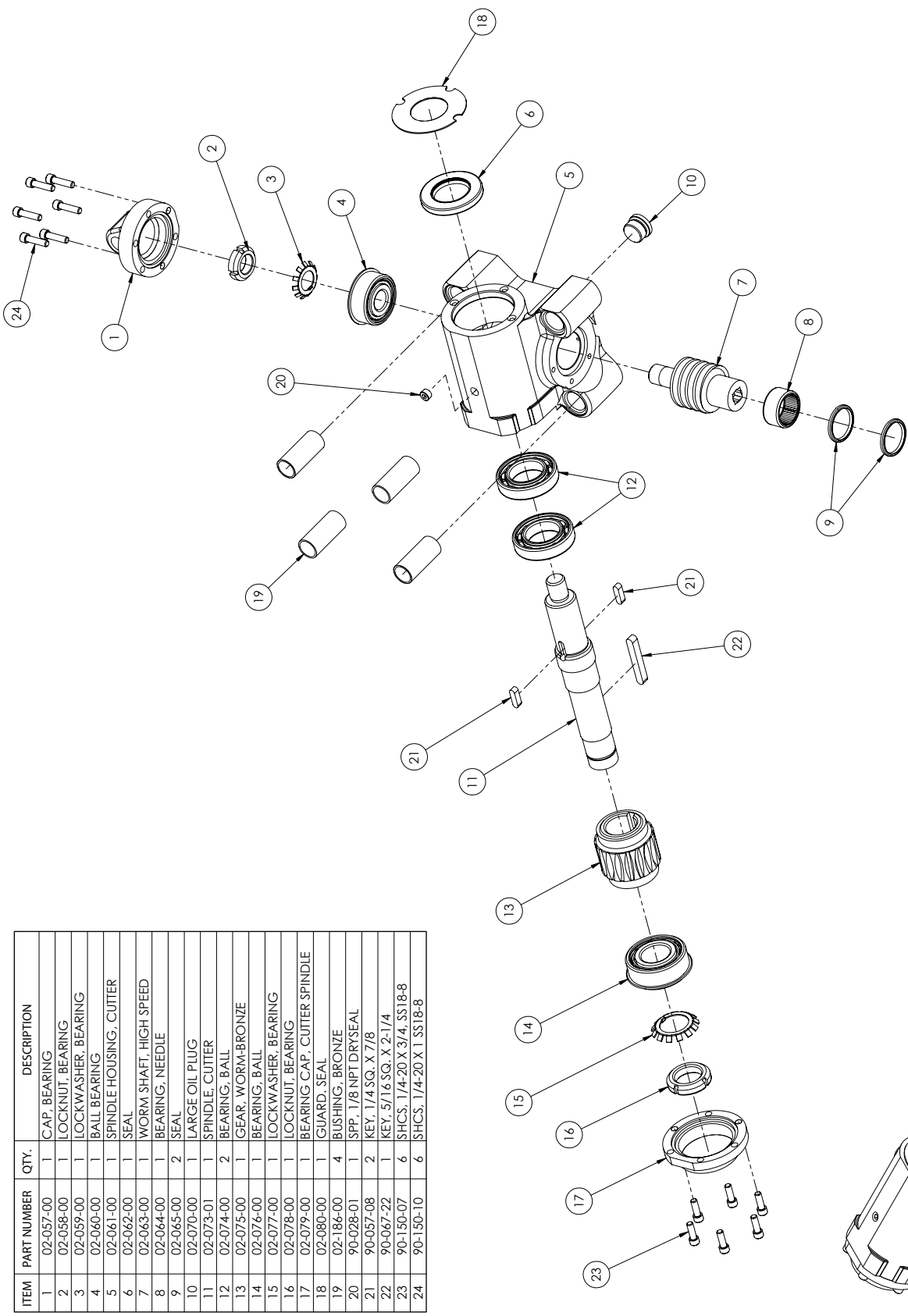

Cutter Spindle Gear Assembly  
02-020-00

ITEM	PART NUMBER	QTY.	DESCRIPTION
1	02-057-00	1	CAP. BEARING
2	02-058-00	1	LOCKNUT BEARING
3	02-059-00	1	LOCKWASHER BEARING
4	02-060-00	1	BALL BEARING
5	02-061-00	1	SPINDLE HOUSING, CUTTER
6	02-062-00	1	SEAL
7	02-063-00	1	WORM SHAFT, HIGH SPEED
8	02-064-00	1	BEARING, NEEDLE
9	02-065-00	2	SEAL
10	02-070-00	1	LARGE OIL PLUG
11	02-073-01	1	SPINDLE, CUTTER
12	02-074-00	2	BEARING, BALL
13	02-075-00	1	GEAR, WORM-BRONZE
14	02-076-00	1	BEARING, BALL
15	02-077-00	1	LOCKWASHER, BEARING
16	02-078-00	1	LOCKNUT, BEARING
17	02-079-00	1	BEARING CAP, CUTTER SPINDLE
18	02-080-00	1	GUARD, SEAL
19	02-186-00	4	BUSHING, BRONZE
20	90-028-01	1	SPP, 1/8 NPT DRY SEAL
21	90-057-08	2	KEY, 1/4 SQ. X 7/8
22	90-067-22	1	KEY, 5/16 SQ. X 2-1/4
23	90-150-07	6	SHCS, 1/4-20 X 3/4, SS18-8
24	90-150-10	6	SHCS, 1/4-20 X 1, SS18-8

ITEM	PART NUMBER	QTY.	DESCRIPTION
1	02-001-00	1	SCREW, FEED
2	02-002-00	1	RING, RETAINING
3	02-003-00	1	BEARING, BALL
4	02-005-00	1	BEARING HOUSING, FEED SCREW
5	02-006-00	1	LOCK NUT, FEED SCREW BEARING

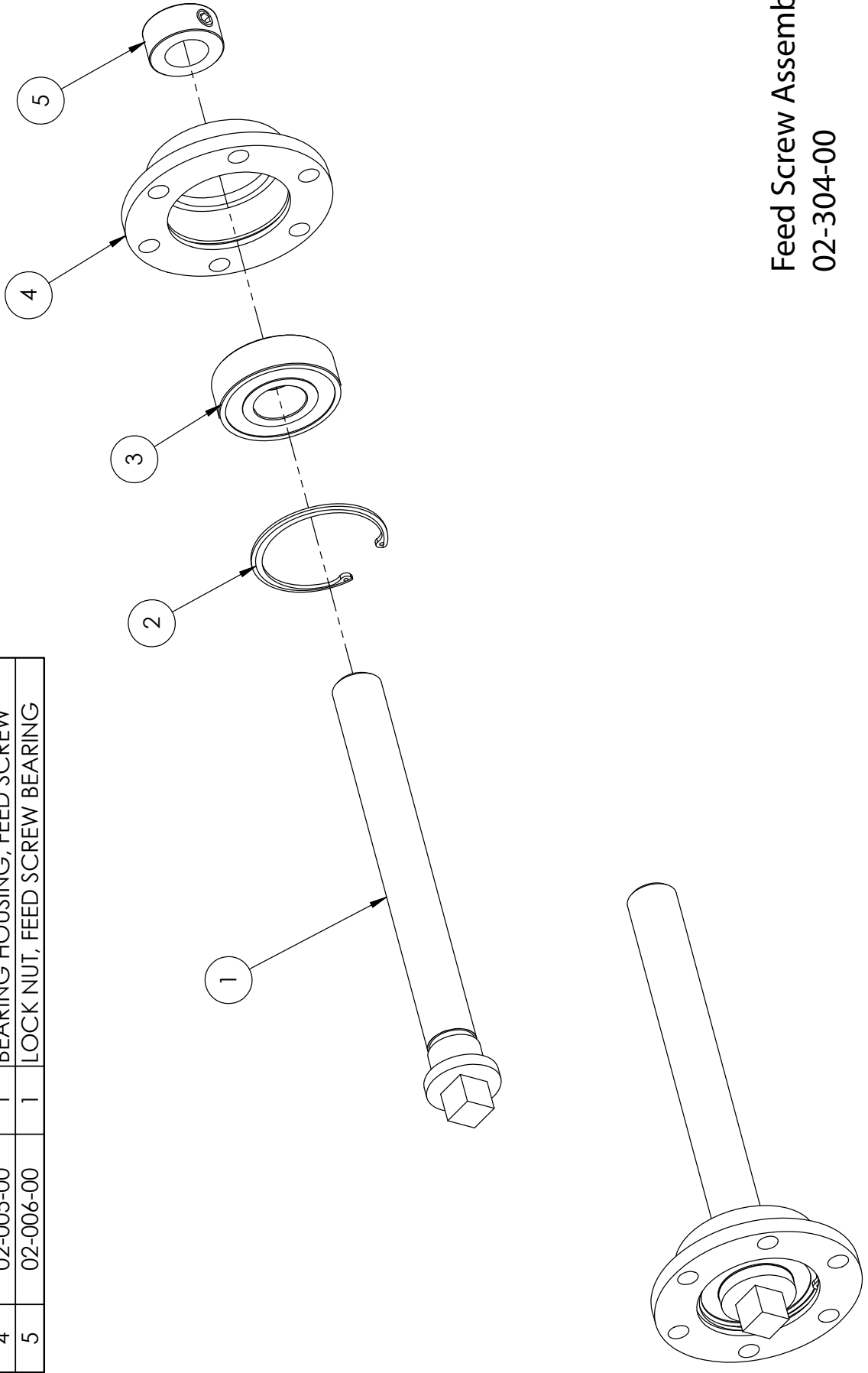

Feed Screw Assembly  
02-304-00

ITEM	PART NUMBER	QTY.	DESCRIPTION
1	02-002-00	2	RING, RETAINING
2	02-151-00	2	BEARING, BALL
3	02-197-01	2	WHEEL, GUIDE TRACK
4	90-190-10	2	SHCS 1/2-13 X 1.0 SS18-8
5	90-195-52	2	WASHER, 1/2 FLAT SS

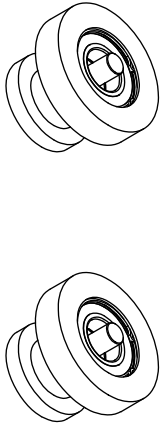
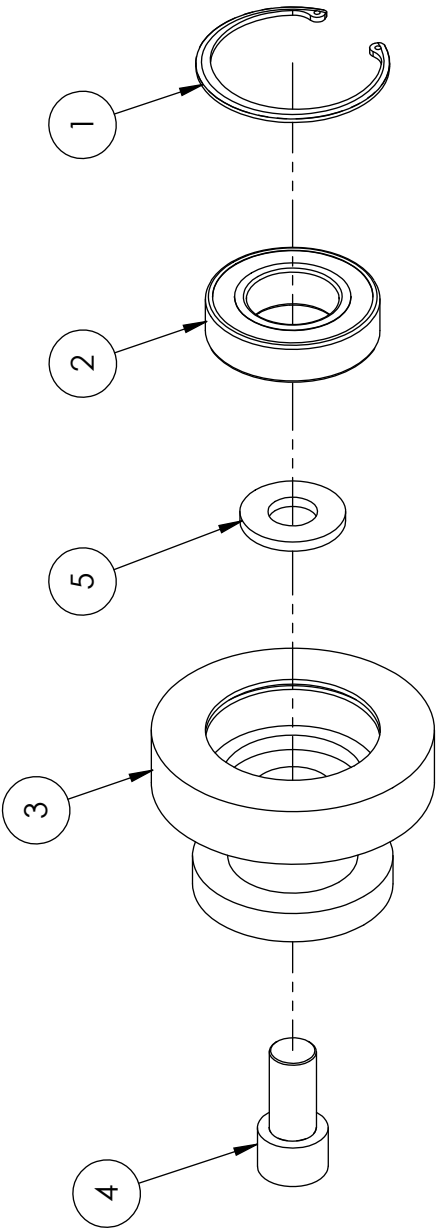
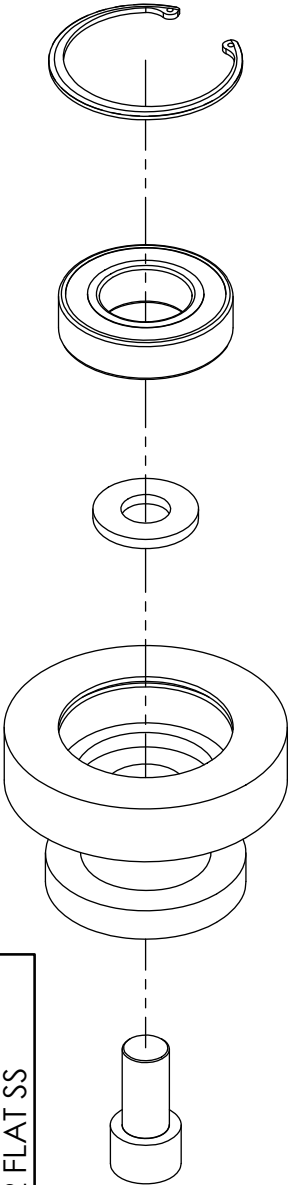

**Guide Track Wheels  
02-429-00**

## BILL OF MATERIAL – SPRAY MIST COOLING SYSTEM

(For automatic coolant applications)

PART No. 02-405-00

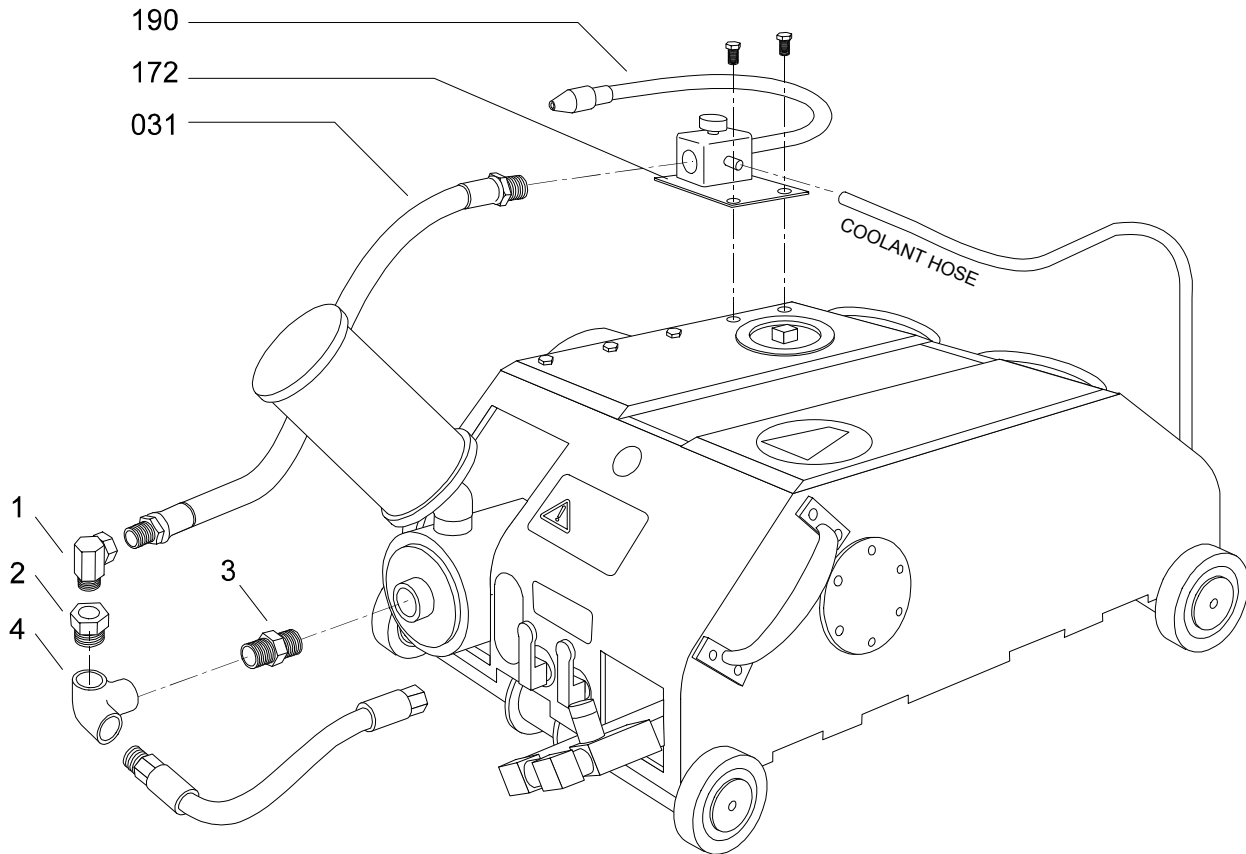

REF	PART NO	QTY	DESCRIPTION
031	02-031-00	1	HOSE, TRAVEL MOTOR
172	02-172-00	1	PLATE, MOUNTING
190	02-190-00	1	ATTACHMENT, SPRAYMIST
1	90-058-51	2	ST.EL, 1/4-45W/SVL LP
2	90-058-57	1	BUSHING, 1/4 X 1/2 HP
3	90-098-01	1	NIPPLE-CLOSE 1/2LP
4	90-098-12	1	ELBOW, SIDE 1/2

**BILL OF MATERIAL – HEAVY DUTY SPRAY MIST SYSTEM**

PART No. 02-430-00

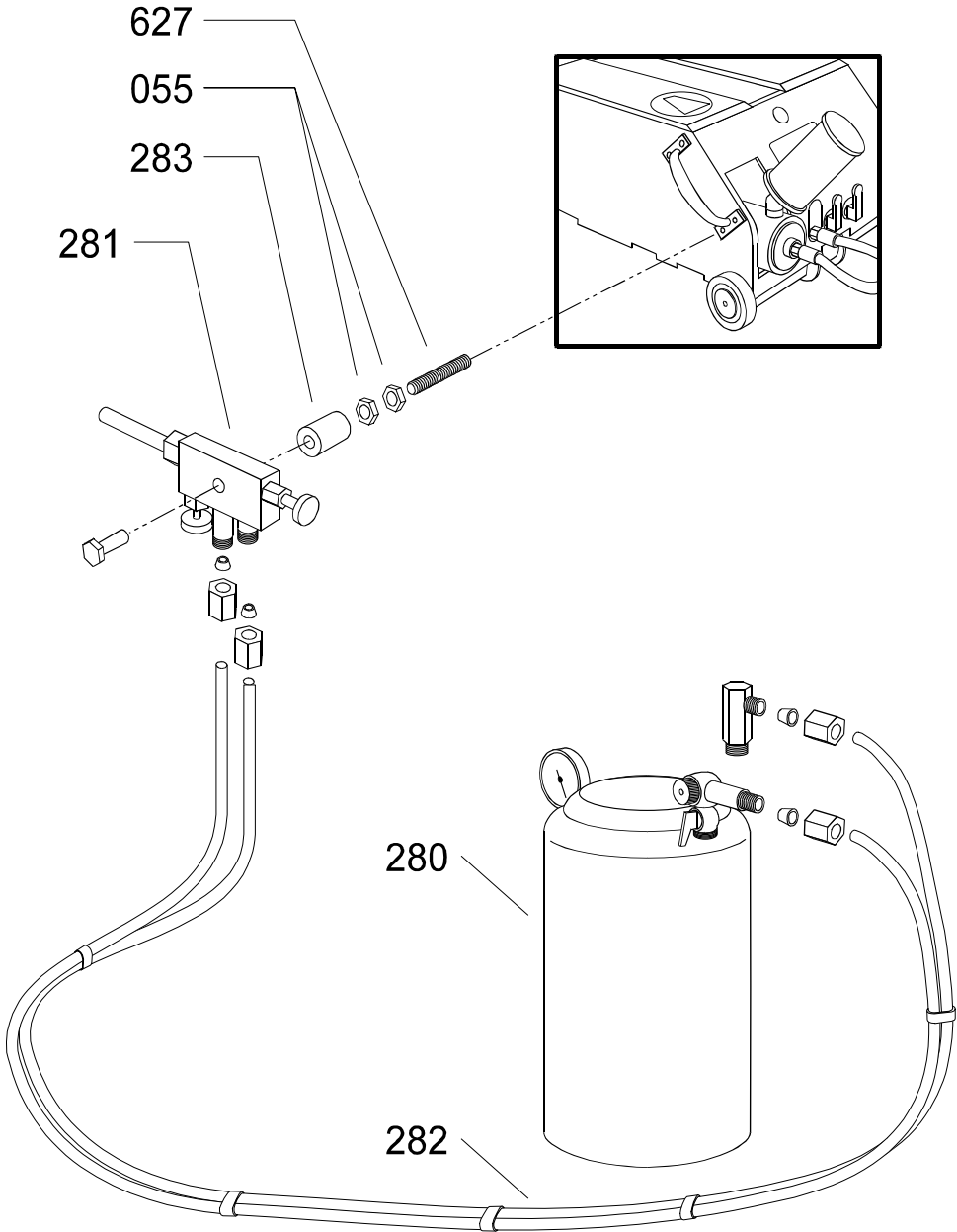

REF	PART NO	QTY	DESCRIPTION
280	02-280-00	1	TANK,PRESSURE
281	02-281-00	1	NOZZLE&VALVE
282	02-282-00	2	HOSE,1/4 X 10'
283	02-283-00	1	BRACKET,MOUNTING
071	56-071-00	1	HANDLE
051	90-051-07	1	HHCS,1/4-20 X 3/4
055	90-055-01	2	2 NUT,HEX 1/4-20

ITEM	PART NUMBER	QTY.	DESCRIPTION
1	02-157-00	67	SILENT CHAIN
2	02-158-00	5	CONNECTING PIN FOR CHAIN

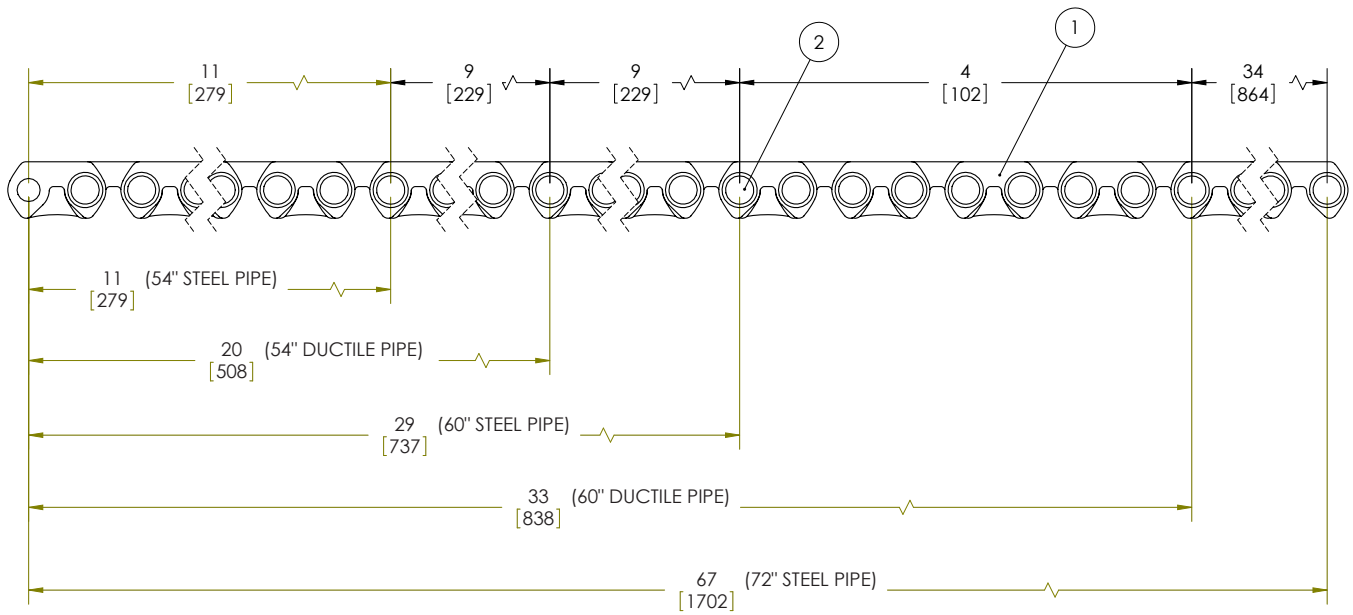
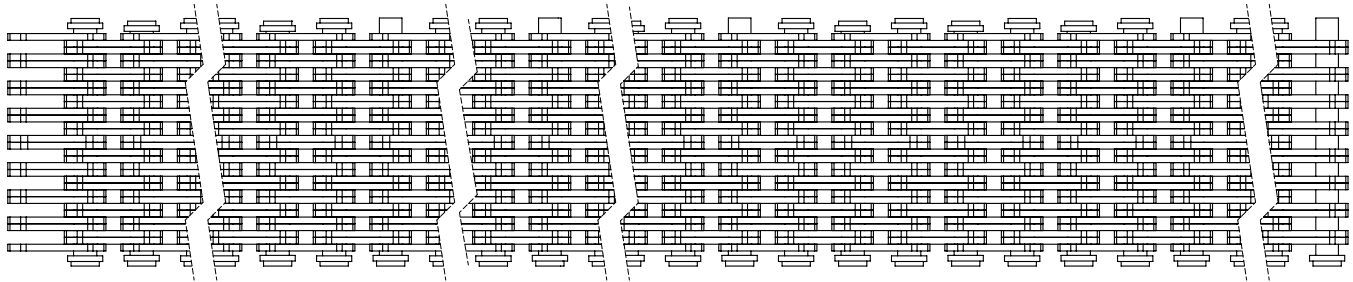



## Chapter 9

# Ordering Information

---

### **ORDERING INFORMATION**

To place an order or to get more detailed information on any E.H. Wachs products, call us at: 1-800-323-8185.

### **ORDERING REPLACEMENT PARTS**

Please use parts lists provided in manual. Have part description and part number of required replacement part or parts to help expedite order and ensure proper parts are being ordered.

### **REPAIR INFORMATION**

Please call E.H. Wachs Company prior to returning any equipment for repair. We will advise you of shipping and handling. Please enclose with equipment to be repaired your name, address, phone number and a brief description of problem or work to be done or estimated.

All repair work done at our plant will be estimated and the customer advised of cost and time required to complete repair.

### **WARRANTY INFORMATION**

Enclosed with the manual is a warranty card. Please fill out the registration card and return to E.H. Wachs.

Retain the owners registration record and warranty card for your information.

**RETURN GOODS ADDRESS**

E.H. Wachs Company  
600 Knightsbridge Parkway  
Lincolnshire, Illinois 60069

Call or Write:

E.H. Wachs Company  
600 Knightsbridge Parkway  
Lincolnshire, Illinois 60069  
847-537-8800  
FAX: 847-520-1147 • 847-520-1168  
Toll-Free: 1-800-323-8185





**E.H.WACHS**

**Superior Equipment. Complete Support.**

600 Knightsbridge Parkway • Lincolnshire, IL 60069  
847-537-8800 • [www.wachsco.com](http://www.wachsco.com)