

TLC SD Model E Pneumatic Kit (shown)
 Part Number 02-5000-01

TLC SD Model HE Hydraulic Kit
 Part Number 02-5000-02

**BRING YOUR
 TRAV-L-CUTTER
 UP
 TO **SD**
 PERFORMANCE**

If your existing Trav-L-Cutter needs repair, or you are looking to upgrade it to the newest Trav-L-Cutter Super Duty capability, Wachs offers the Trav-L-Cutter Super Duty (TLC SD) Upgrade Kit for select Model E Pneumatic and Model HE Hydraulic machine tools.

UPGRADED COMPONENTS

The Wachs TLC SD Upgrade Kit includes the major internal assemblies (spindle cutter drive and feed drive) and other components needed to upgrade your Wachs Trav-L-Cutter to the newest SD specification, at a fraction of the cost of a new machine.

The upgraded machine delivers longer life and superior performance, allowing it to run cooler for longer periods in extreme environments. This greatly expanded duty cycle is why the newest version of the Trav-L-Cutter, and the Upgrade Kit, is dubbed "Super Duty".

Offered for both pneumatic and hydraulic Trav-L-Cutter models, the SD Upgrade Kits include:

- A redesigned, larger and more robust cutter spindle gearbox, with cast-in-place cooling fins and heat-dissipating coating.
- Four new spindle assembly compression springs.
- New design feed drive assembly with cast-in cooling fins, chain tensioner and revised drive ratios.
- New longer chain and master link, designed for the new feed system assembly and chain tensioner.
- New spindle and feed system housings come prefilled with long-lasting synthetic fluid.
- New heavy duty overload coupling connecting the secondary air motor to the feed drive, designed to accommodate the machine's increased duty cycle.
- New air manifold (on Model E Pneumatic kits) to apportion the air supply more efficiently between the spindle and feed drive air motors.
- All required installation hardware.

INSTALLATION OPTIONS

These kits are designed for installation by a mechanic or technician; factory installation service is available as an extra cost option. Once upgraded, your Trav-L-Cutter is a virtually new machine, apart from the drive motors (which are reused). It is a highly cost effective way to rehabilitate older Trav-L-Cutters, and bring functioning machines up to the newest capabilities.

Contact your local Wachs representative for additional details on the TLC SD Upgrade Kit and to confirm your Trav-L-Cutter is compatible. You can also call the factory at (847) 537-8800 or visit us online at ehwachs.com.



Trav- L-Cutter SD Upgrade Kit

PORTABLE MILLING

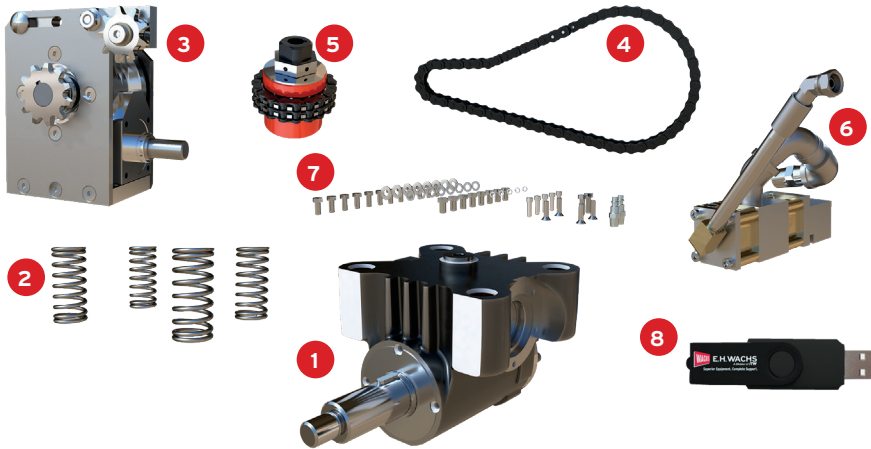

TLC SD Model E Pneumatic Kit (shown)
 Part Number 02-5000-01

TLC SD Model HE Hydraulic Kit
 Part Number 02-5000-02

INCLUDED COMPONENTS

1. Cutter spindle gearbox assembly, prefilled
2. Cutter spindle gearbox compression springs
3. Feed drive gearbox assembly, prefilled
4. Feed drive gearbox chain and master link
5. Heavy duty overload coupling
6. Upgrade air manifold (Pneumatic kit only)
7. Required installation hardware
8. USB drive video installation instructions

Pneumatic or hydraulic drive motors (primary and secondary) not included.

OPTIONAL COMPONENTS

- Replacement or additional sections mounting/drive chain
- Replacement synthetic gear oil
- Genuine Wachs Tooling
- Replacement or Refurbishing of Primary or Secondary drive motors



Heavy Duty Overload Coupling

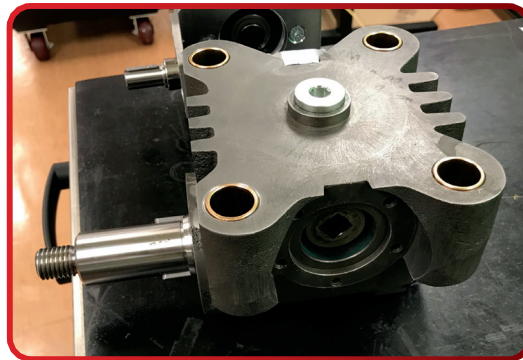

Redesigned Cutter Spindle Gearbox Assembly

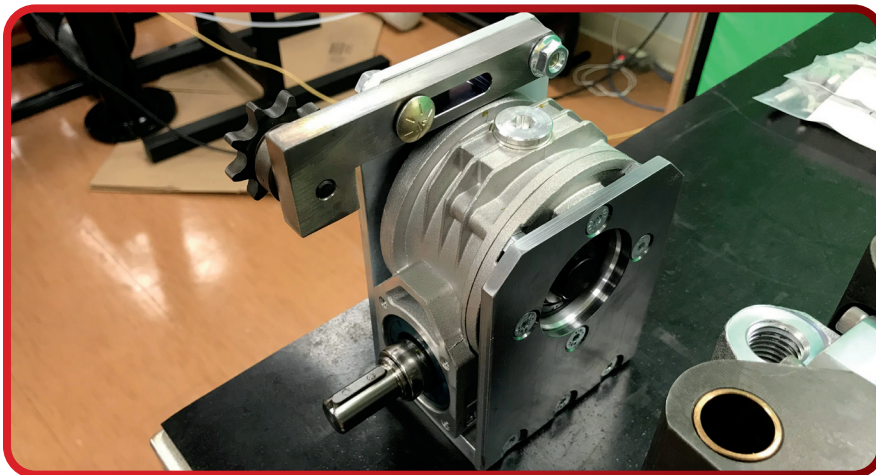

Feed Drive Assembly with Chain Tensioner



Need to Rent a Trav-L-Cutter SD?
 Ask your local sales representative about Wachs Rentals.