

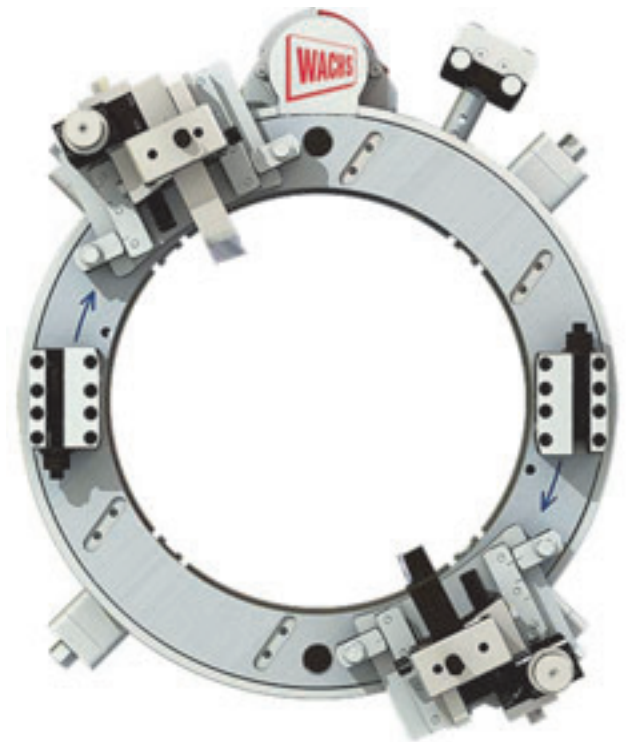

E.H. Wachs
600 Knightsbridge Parkway
Lincolnshire, IL 60069
www.ehwachs.com

DynaPrep MSDF

Manuel de maintenance



E.H. Wachs - Réf. 69-MAN-02
Rév. C, Janvier 2017

Révisions :

Rév. A Octobre 2015

Rév. B Janvier 2016

Droit d'auteur © 2017 E.H. Wachs. Tous droits réservés
Ce manuel ne peut pas être reproduit totalement ou partiellement
sans l'accord écrit de E.H. Wachs.

Table of Contents

Chapter 1: À propos de ce manuel	1
Objectif de ce manuel	1
Comment utiliser le manuel	1
Symboles - Avertissements	2
Information de sécurité	2
Informations commerciales	2
Commande de pièces de rechange	3
Informations pour les réparations	3
Informations sur la garantie	3
Adresse de retour de marchandises	3
Chapter 2: Instructions de service et de réparation	5
Réglage des roulements	5
Réglage du plateau	6
Réglage de la tension du plateau	7
Inversion des cache-rails	11
Chapter 3: Ensembles machine et rotor	15
MDSF 6 po, 69-0000-06	16
MDSF 8 po, 69-0000-08	17
MDSF 10 po, 69-0000-10	18
MDSF 12 po, 69-0000-12	19
MDSF 14 po, 69-0000-14	20
MDSF 16 po, 69-0000-16	21
MDSF 18 po, 69-0000-18	22
MDSF 20 po, 69-0000-20	23
MDSF 24 po, 69-0000-24	24
MDSF 28 po, 69-0000-28	25
MDSF 32 po, 69-0000-32	26
MDSF 36 po, 69-0000-36	27
Ensemble du rotor 6 et 8 po, 69-4000-XX	28
Ensemble du rotor 10 et 48 po, 69-4000-XX	29
Ensemble du rotor 54 et 60 po, 69-4000-XX	30
Ensemble du châssis fixe 6 po, 69-4001-06	31
Ensemble du châssis fixe 8 po, 69-4001-08	32
Ensemble du châssis fixe 10 po, 69-4001-10	33
Ensemble du châssis fixe 12 po, 69-4001-12	34
Ensemble du châssis fixe 14 po, 69-4001-14	35
Ensemble du châssis fixe 16 po, 69-4001-16	36
Ensemble du châssis fixe 18 po, 69-4001-18	37
Ensemble du châssis fixe 20 po, 69-4001-20	38
Ensemble du châssis fixe 24 po, 69-4001-24	39

Ensemble du châssis fixe 28 po, 69-4001-28	40
Ensemble du châssis fixe 32 po, 69-4001-32	41
Ensemble du châssis fixe 36 po, 69-4001-36	42
Ensemble du châssis fixe 42 po, 69-4001-42	43
Ensemble du châssis fixe 48 po, 69-4001-48	44
Ensemble du châssis fixe 54 po, 69-4001-54	45
Ensemble du châssis fixe 60 po, 69-4001-60	46
Pied de réglage axial, 69-3062-00	47
Ensemble de vis de bridage, 69-4500-02	47
Chapter 4: Transmissions, adaptateur de transmission et accessoires d'alimentation	49
Ensemble pignon, 1/2" entraînement carré, 69-3025-01	50
Sous-ensemble de transmission avant du pignon, 69-3038-00	51
Ensemble de pignons traditionnels, 69-4480-01	52
Ensemble de pignons traditionnels de la transmission avant, 69-4480-01	52
Ensemble de pignons standard, 69-4482-01	53
Moteur, transmission pneumatique 3 cv, 69-4351-00	54
Moteur, transmission pneumatique 1,5 cv à renvoi d'angle (CE), 69-4352-00	55
Moteur, transmission pneumatique 1,5 cv à renvoi d'angle avec poignée, 69-4354-00	56
Moteur, transmission pneumatique 4 cv, 69-4355-00	57
Moteur, transmission pneumatique 3 cv avec poignée, 69-4353-01	57
Ensemble moteur à transmission pneumatique 3 cv, 69-3030-00	58
Moteur, transmission pneumatique 4 cv avec poignée, 69-4356-00	58
Ensemble moteur à transmission pneumatique 4 cv, 69-3028-00	59
Module pneumatique d'utilisation à distance, 69-4101-00	60
ACM et ensemble de supports, 69-3061-00	61
Ensemble plaque de montage Marche/arrêt, 69-3059-00	62
Module de traitement de l'air, 69-4102-00	62
FRL et ensemble de supports, 69-3042-00	63
Transmission hydraulique complète, 69-4358-00	64
Ensemble transmission hydraulique, utilisation à distance, 69-4358-01	65
Sous-ensemble collecteur hydraulique, 69-3026-00	66
Commande électrique par entraînement (230 V, monophasée), 69-4357-01	67
Commande électrique par entraînement (220-480 V, triphasée), 69-4357-03	67
Chapter 5: Porte-outils et déclencheurs	69
Plateaux standard	69
Ensemble de plateaux	70
Porte-outils à lamer	71
Ensemble embouts de chanfreinage 3 po, 69-3022-03	72
Ensemble embouts de chanfreinage 6 po, 69-3022-06	72
Ensemble barre de chanfreinage 3 po, 69-3023-03	73
Ensemble base de chanfreinage, 60-434-00	74
DIAMÈTRE EXTÉRIEUR Suiveurs de profil	75
DIAMÈTRE EXTÉRIEUR Suiveur de profil, 69-4604-01	75

DIAMÈTRE EXTÉRIEUR Sous-ensemble suiveurs de profil, 69-3036-01	76
DIAMÈTRE EXTÉRIEUR Ensemble porte-outils de suiveurs de profil, 69-3035-00	77
Kit d"adaptateur pour traverse, 69-5300-00	77
Ensembles de déclenchement	78
Déclencheur manuel, 69-3018-00	78
Déclencheur pneumatique avec commande à distance, 69-4741-00	78
Déclencheur pneumatique avec commande à distance, 69-4741-00	79
Ensemble déclencheur pneumatique, 60-434-00	79
Déclencheur pneumatique, 69-3020-00	80
Ensemble déclencheur double, 69-3046-00	80
Ensemble déclencheur monté sur ressort pour diamètre extérieur Suiveurs de profil, 69-4744-01	81

Chapitre 1

À propos de ce manuel

OBJECTIF DE CE MANUEL

Ce manuel décrit le mode d'utilisation de la machine DynaPrep MDSF. Il comprend des informations de sécurité pour une utilisation sécuritaire de la machine, des consignes pour la maintenance préventive, et des procédures de dépannage.

Avant d'utiliser la DynaPrep, vous devez lire attentivement ce manuel et vous familiariser avec toutes les instructions.

Un manuel de maintenance séparé est fourni. Le *Manuel de maintenance DynaPrep MDSF* inclut des informations relatives à l'entretien, aux réparations, à la nomenclature, aux dessins et à la commande de pièces.





COMMENT UTILISER LE MANUEL

Ce manuel se compose des chapitres suivants :

- **Le Chapitre 2 - Entretien et réparations**, décrit les procédures de réglage et de réparation que le propriétaire de la DynaPrep peut effectuer. Veuillez noter que les procédures de maintenance préventive standard sont décrites dans le *Manuel de l'opérateur MDSF*.
- **Le chapitre 2, Ensembles machine et rotor**, contient les dessins et listes de pièces des différents éléments des ensembles machines et rotors de la gamme DynaPrep MDSF.
- **Le chapitre 4, Transmissions, adaptateur de transmission et accessoires d'alimentation**, contient les dessins et listes de pièces des différents éléments moteurs et de transmission.
- **Le chapitre 5, Porte-outils et déclencheurs**, contient les dessins et listes de pièces de tous les ensembles porte-outils et déclencheurs disponibles de la DynaPrep MDSF.

SYMBOLES - AVERTISSEMENTS

Les symboles suivants utilisés dans ce manuel indiquent des remarques particulières, des avertissements, et des mises en garde. Soyez sûr de bien comprendre la signification de chaque symbole et respectez toutes les instructions concernant les précautions et les avertissements.

 AVERTISSEMENT	Un AVERTISSEMENT avec le symbole d'alerte de sécurité indique une situation potentiellement dangereuse qui peut entraîner des blessures graves ou la mort .
 ATTENTION	Le symbole ATTENTION avec une alerte de sécurité indique une situation potentiellement dangereuse qui peut entraîner des blessures légères ou mineures .
 ATTENTION	Symbole de risque de détérioration du matériel. Ce symbole est utilisé pour vous alerter à propos de risques potentiels de détérioration du matériel . Respectez tous les messages suivant ce symbole pour éviter d'endommager le matériel et la pièce usinée.
 REMARQUE	Ce symbole indique une remarque à l'intention de l'utilisateur. Les Remarques fournissent des informations qui complètent les instructions ou des conseils pour faciliter l'utilisation.

INFORMATION DE SÉCURITÉ

Reportez-vous au Chapitre 2, « Sécurité », du *Manuel de l'opérateur DynaPrep MSDF* pour toutes les consignes de sécurité d'utilisation et de manipulation. Prenez note du poids des machines et ensembles DynaPrep et utilisez les dispositifs de levage appropriés si nécessaire.

INFORMATIONS COMMERCIALES

Pour passer une commande, demander une intervention ou obtenir des détails sur les produits E.H. Wachs, veuillez nous appeler à un des numéros suivants :

ÉTATS-UNIS 800-323-8185
International : 847-537-8800

Vous pouvez également visiter notre site web à l'adresse :

www.ehwachs.com

Commande de pièces de rechange

Pour commander des pièces, veuillez vous reporter aux dessins et nomenclatures des Chapitres 3 - 5. Merci de fournir la description et la référence de toute pièce commandée.

Informations pour les réparations

Veuillez nous appeler pour obtenir un numéro d'autorisation avant de retourner un matériel pour une réparation ou une intervention d'entretien en usine. Nous vous informerons à propos de l'expédition et de la manutention. Lors de l'envoi du matériel, merci de fournir les informations suivantes :

- Votre nom / Nom de la société
- Votre adresse
- Votre numéro de téléphone
- Une description du problème ou du travail à effectuer.

Avant d'effectuer une réparation, nous établissons un devis que nous vous remettons et vous informons du délai nécessaire à l'exécution du travail.

Informations sur la garantie

Ce manuel est fourni avec une carte de garantie. Merci de remplir la carte d'enregistrement de la garantie et de la retourner à E.H. Wachs. Conservez l'enregistrement et la carte de garantie pour votre information.

Adresse de retour de marchandises

Retournez le matériel à réparer à l'adresse suivante.

E.H. Wachs
600 Knightsbridge Parkway
Lincolnshire, Illinois 60069 USA

Chapitre 2

Instructions de service et de réparation

RÉGLAGE DES ROULEMENTS

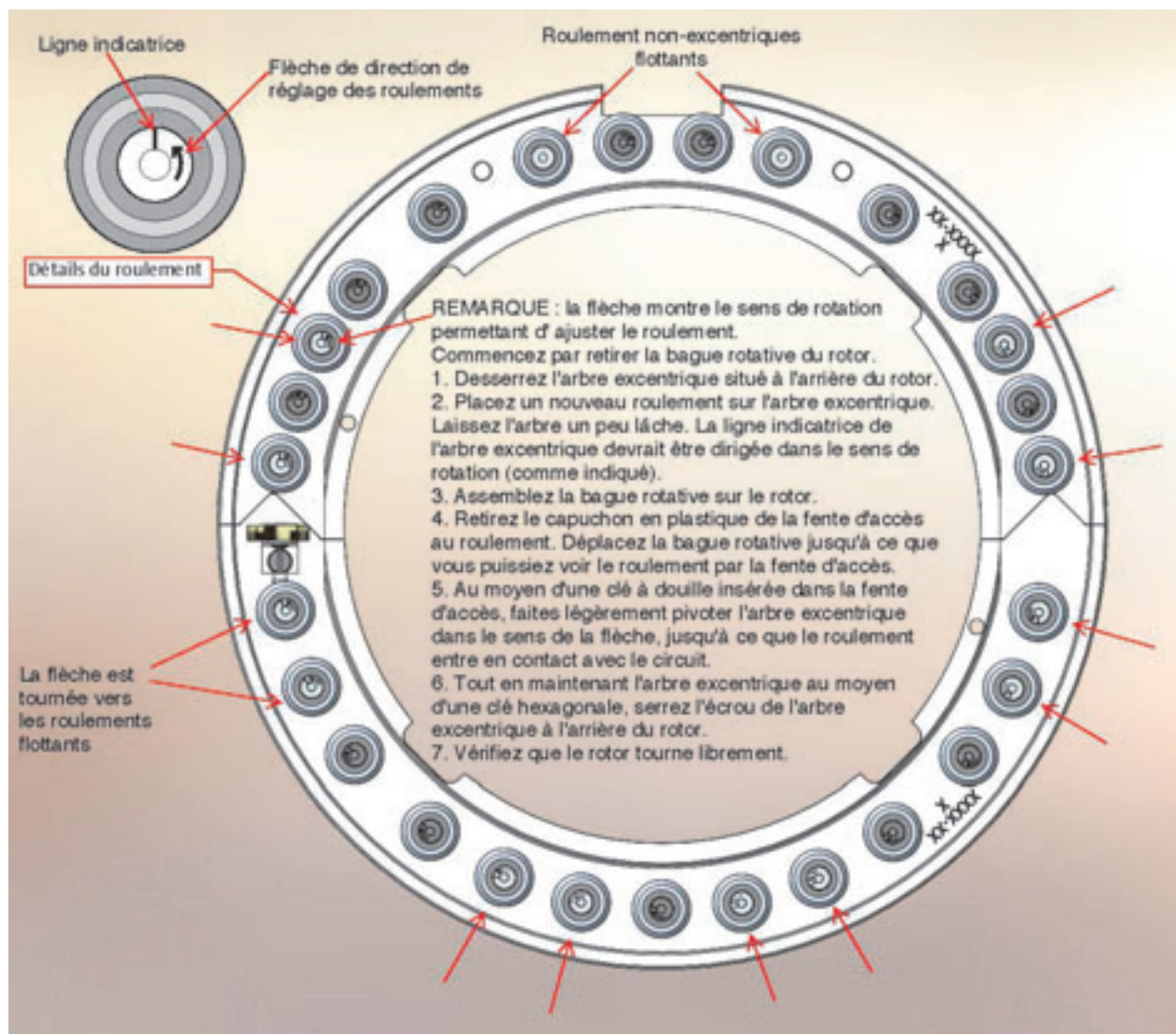

RÉGLAGE DU PLATEAU

Dès que vous utilisez les plateaux de la machine MSDF, pensez à vérifier que le plateau mâle est bien serré, sans jeu au niveau de la base.

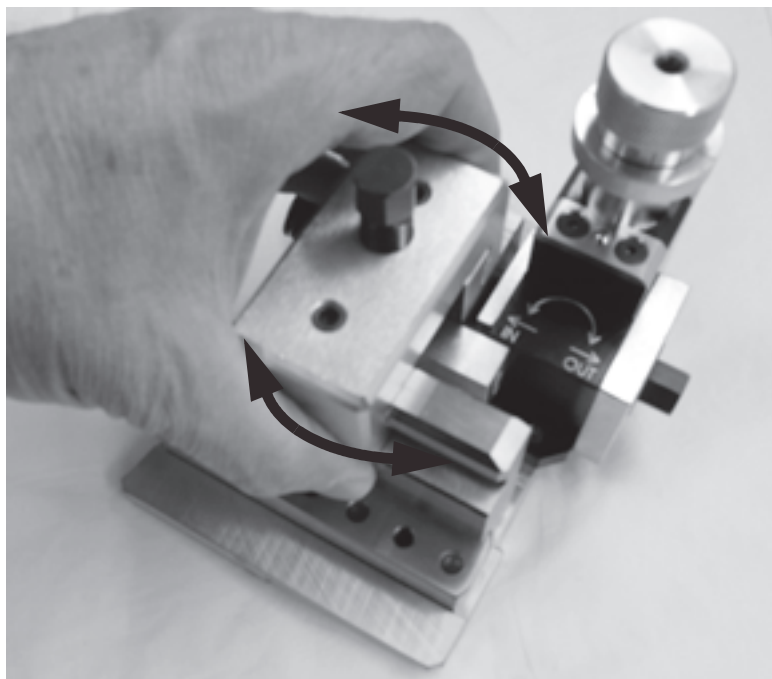

Figure 2-1. Une fois le plateau installé sur un établi, maintenez le charriot-outils et essayez de le faire bouger d'un côté à l'autre, entre les rails.

- Le charriot devrait être bien fixé entre les rails, sans jeu bord-à-bord.
- Si vous parvenez à faire bouger le charriot d'un bord à l'autre, reportez-vous à la rubrique « Réglage de la tension du plateau » ci-dessous.

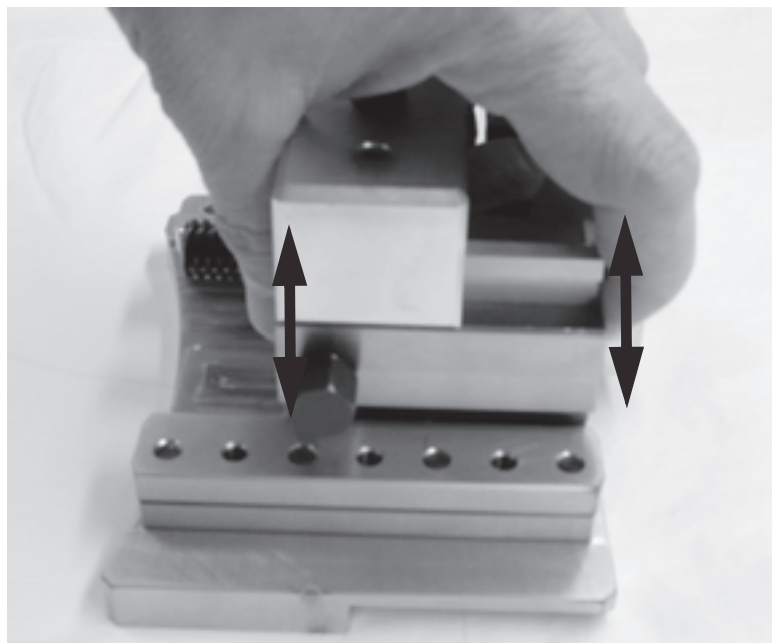

Figure 2-2. Ensuite, tentez d'incliner le charriot de l'avant vers l'arrière et de bas en haut. Cela peut s'avérer plus facile avec un outil installé sur le porte-outils, pour faire effet de levier.

- Le charriot devrait être bien fixe, sans déplacement de bas en haut.
- Si vous parvenez à faire bouger le charriot de bas en haut, reportez-vous à la rubrique « Inversion des cache-rails » ci-dessous.

Réglage de la tension du plateau.

Ajustez la tension du plateau en utilisant les vis de serrage sur le rail réglable. Aucune vis de serrage n'est présente sur le rail fixe.

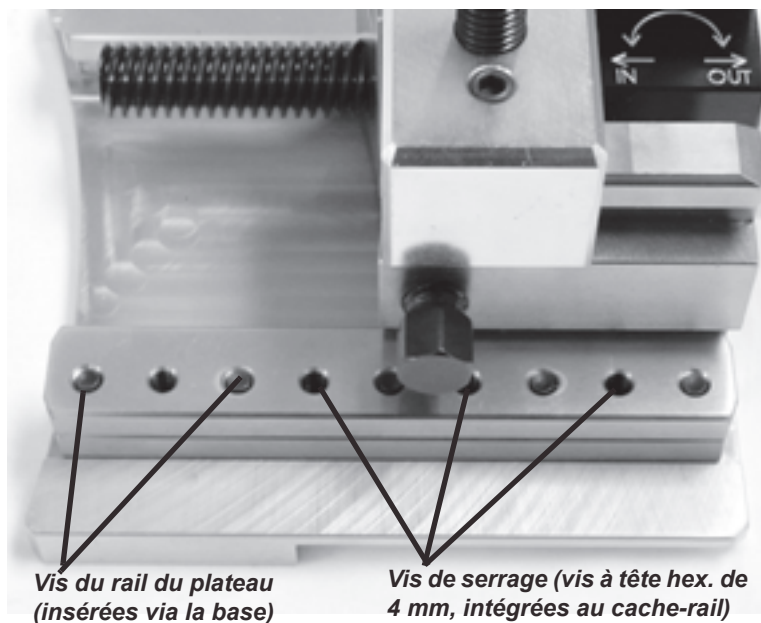
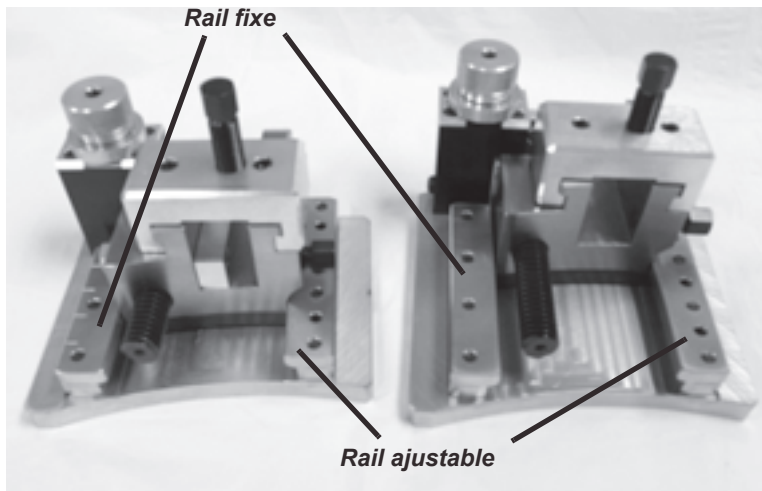
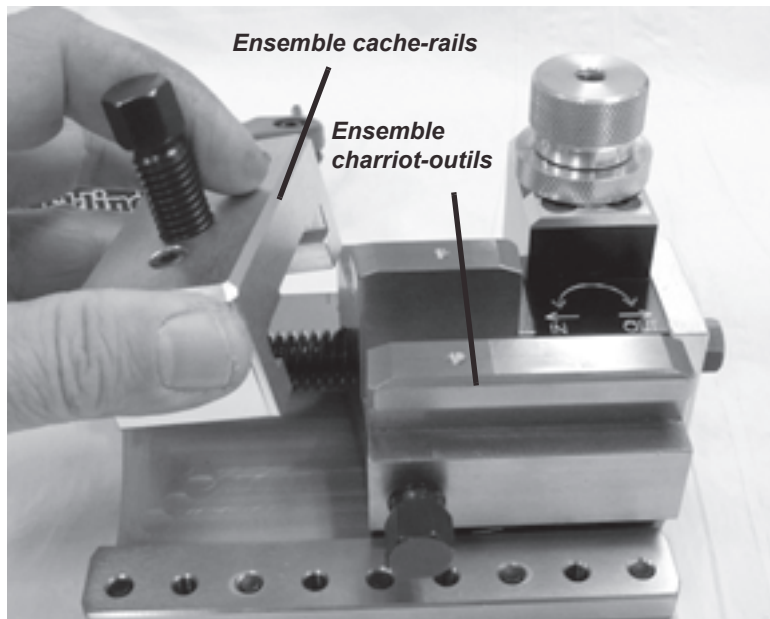

Figure 2-3. Utilisez les vis de serrage sur le rail ajustable pour régler la tension de l'avance sur le plateau. Les vis de serrage alternent avec les vis du rail du plateau.

- Plateaux 1,5" et 2,5" représentés.
- Les rails des plateaux de dimensions plus larges sont munis de plus de vis , mais la procédure de réglage est la même.



1. Retirez l'ensemble cache-outils.

- Desserrez les 2 vis de réglage (avec une clé hex. de 4 mm), puis faites glisser l'ensemble hors du charriot.

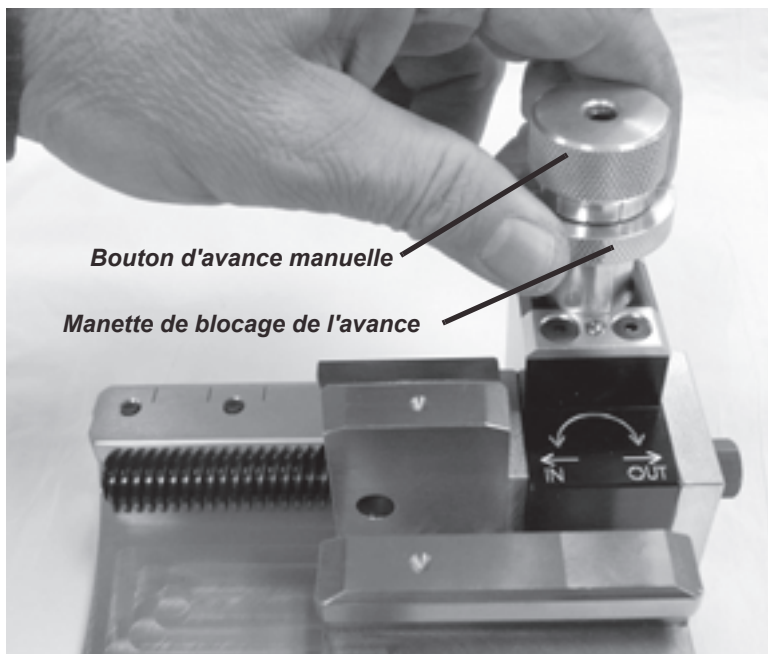

2. Désengagez l'avance de sorte à pouvoir déplacer le plateau au moyen du dispositif de rétractation rapide.

- Desserrez le bouton de blocage de l'avance en l'enclenchant vers le bas et en le faisant pivoter dans le sens horaire.
- Dévissez le bouton d'avance manuel jusqu'à ce qu'il pivote librement.
- Faites tourner le bouton de blocage de l'avance dans le sens anti-horaire afin de maintenir le bouton d'avance vers le haut en position verticale et désengagée.

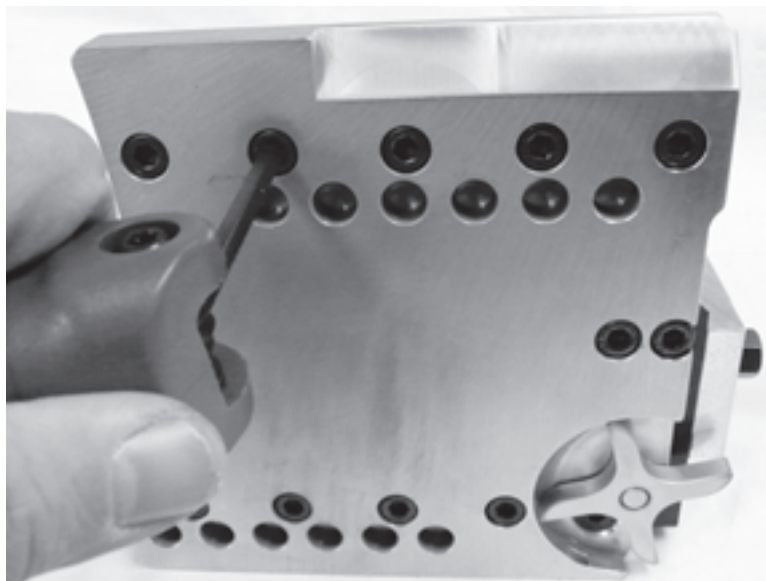

3. Sur la partie inférieure du plateau, desserrez les vis du rail du plateau, au niveau du rail ajustable.

- Utilisez une clé hexagonale de 5 mm.
- Faites tourner les vis pour les desserrer, puis resserrez-les de sorte à ce que le rail ne puisse plus bouger librement.
- Ne serrez aucune vis de serrage au niveau du rail fixe.

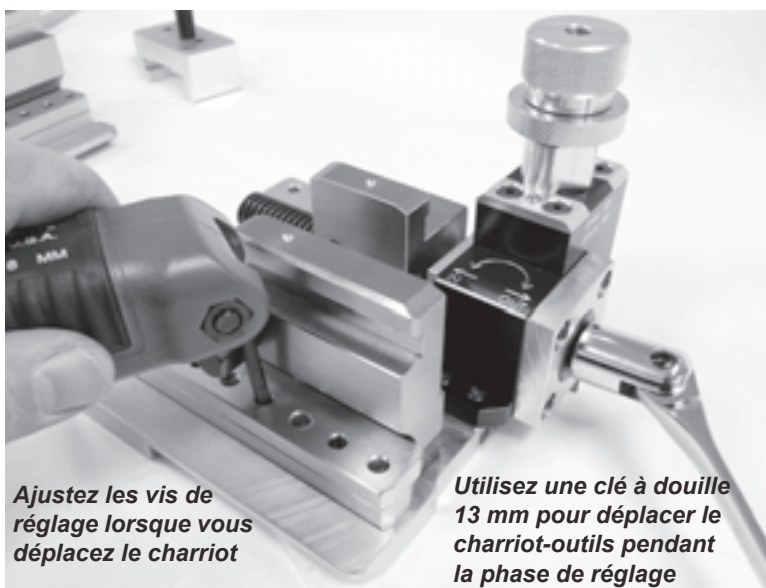

Ajustez les vis de réglage lorsque vous déplacez le charriot

Utilisez une clé à douille 13 mm pour déplacer le charriot-outils pendant la phase de réglage

4. En débutant au centre du cache-rails, ajustez les vis de serrage du plateau et faites pivoter l'écrou à rétraction rapide pour ressentir la tension au niveau du plateau, sur toute la longueur de déplacement.

- Utilisez une clé hexagonale de 4 mm pour les vis de réglage.
- L'écrou à rétraction rapide devrait tourner librement et facilement au moyen de la clé à douille. Vous ne devriez **pas** être en mesure de faire pivoter l'écrou manuellement.
- Déplacez le charriot en direction des vis de réglage pendant l'ajustement de la vis.
- Commencez depuis le centre du plateau, et faites bouger le charriot tout en ajustant chaque vis de serrage à proximité du milieu du charriot.
- Vérifiez que le mouvement est souple et qu'une tension est présente tout au long de la course. Réajustez les vis selon les besoins.

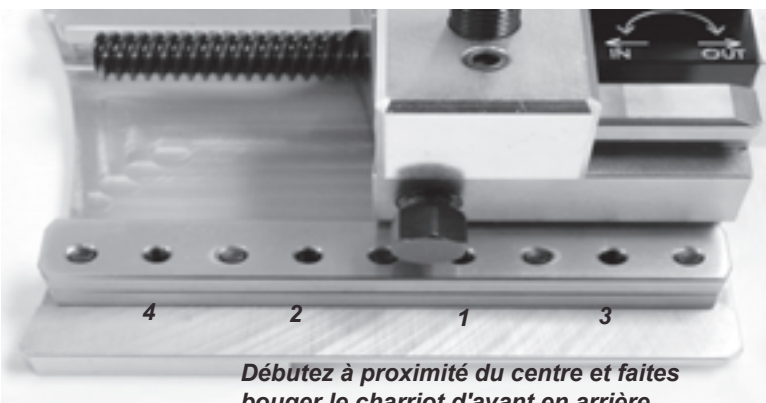

Débutez à proximité du centre et faites bouger le charriot d'avant en arrière, en direction de l'extrémité du plateau



- 5.** Resserrez les vis du rail du plateau, au niveau de la partie inférieure du plateau.
- Vérifiez la tension en faisant avancer le plateau sur toute la longueur.
 - Si besoin, desserrez les vis du rail du plateau et répétez la procédure de réglage.

Inversion des cache-rails

L'usure sur la partie inférieure du cache-rails peut donner lieu à un jeu entre le plateau mâle et la base du plateau. Les cache-rails sont conçus pour être installés des deux côtés. Lorsque l'usure est trop importante pour permettre un jeu, retirez-les et installez-les de l'autre côté.

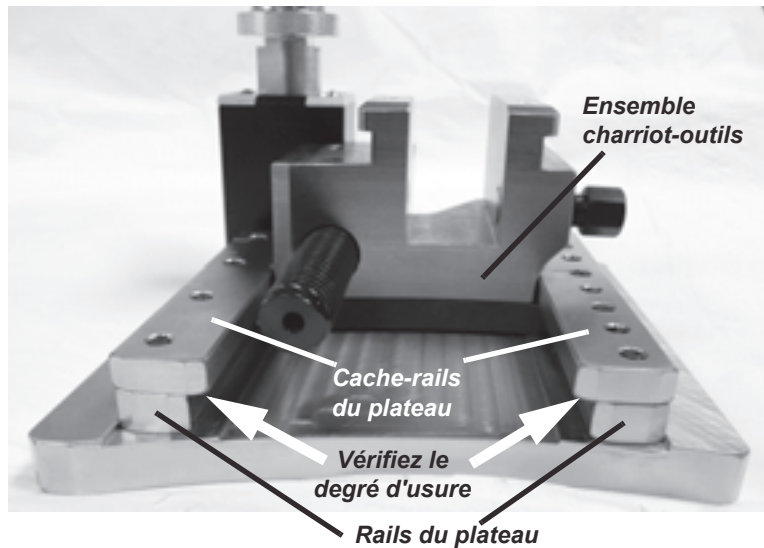
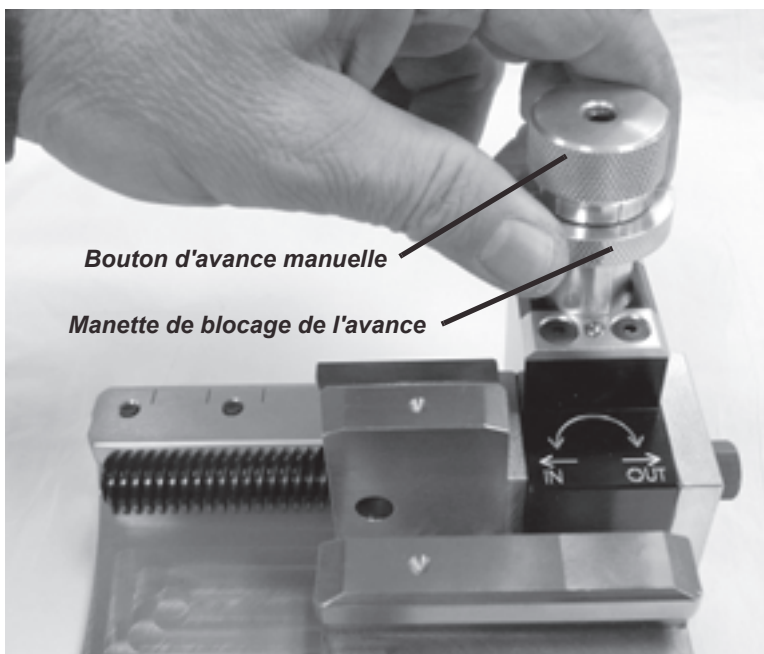
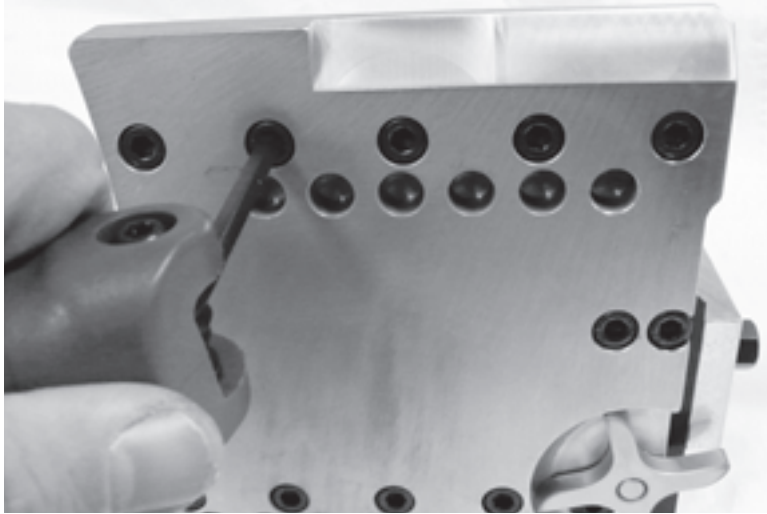

Figure 2-4. L'usure sur la partie inférieure du cache-rails peut donner lieu à un jeu ou à une instabilité du plateau.

- Si vous parvenez à faire bouger le charriot de bas en haut, il est probable que les cache-rails soient usés.
- Les cache-rails peuvent être installés du côté de votre choix. Lorsque l'un des côtés est usé, retournez-le.
- Lorsque les deux côtés sont usés, la base du plateau doit être remplacée.



1. Désengagez l'avance de sorte à pouvoir déplacer le plateau au moyen du dispositif de rétractation rapide.
 - Desserrez le bouton de blocage de l'avance en l'enclenchant vers le bas et en le faisant pivoter dans le sens horaire.
 - Dévissez le bouton d'avance manuel jusqu'à ce qu'il pivote librement.
 - Faites tourner le bouton de blocage de l'avance dans le sens anti-horaire afin de maintenir le bouton d'avance vers le haut en position verticale et désengagée.



2. Sur la partie inférieure du plateau, desserrez les vis du rail du plateau, au niveau des deux rails.

- Utilisez une clé hexagonale de 5 mm.

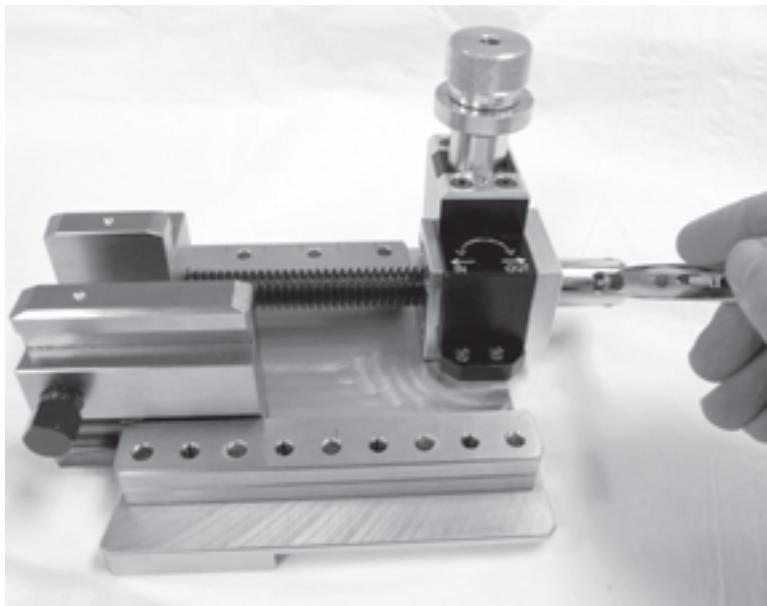

3. Faites pivoter l'écrou à rétractation rapide pour faire avancer le charriot le long de la vis d'avance.

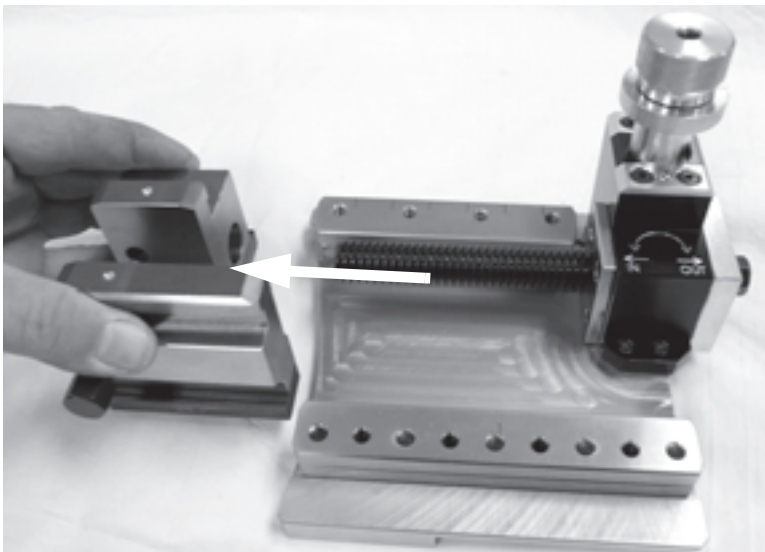

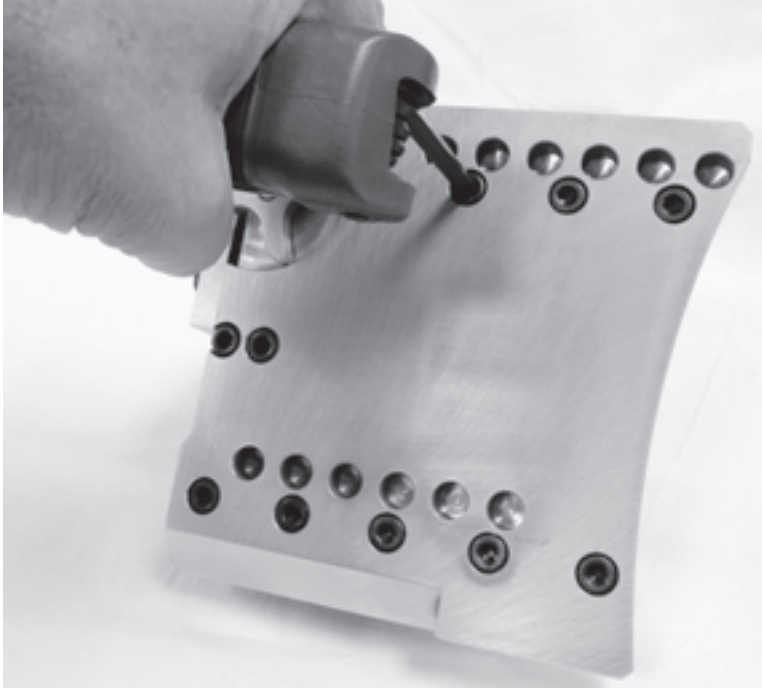

- 4.** Retirez les vis du rail du plateau.

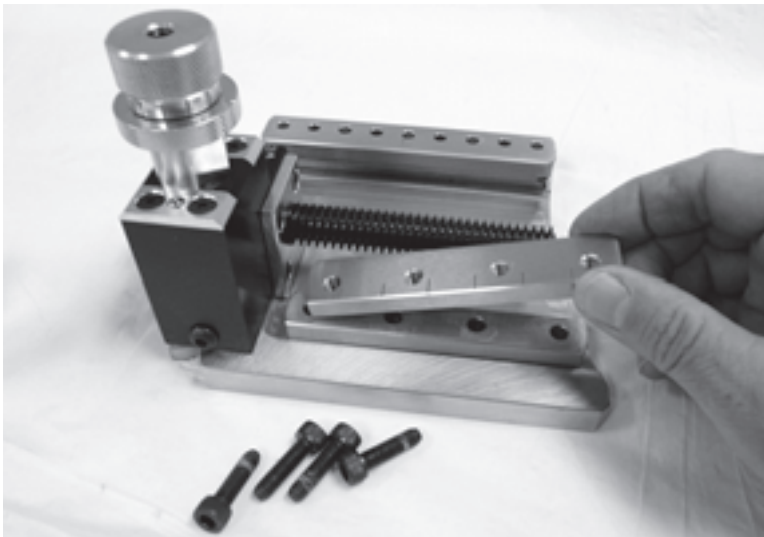

- 5.** Inclinez les cache-rails d'une extrémité à l'autre. Notez que les marquages sont gravés des deux côtés des caches.
- 6.** Remplacez les vis du rail du plateau via la partie inférieure du plateau. Laissez les vis légèrement lâches.

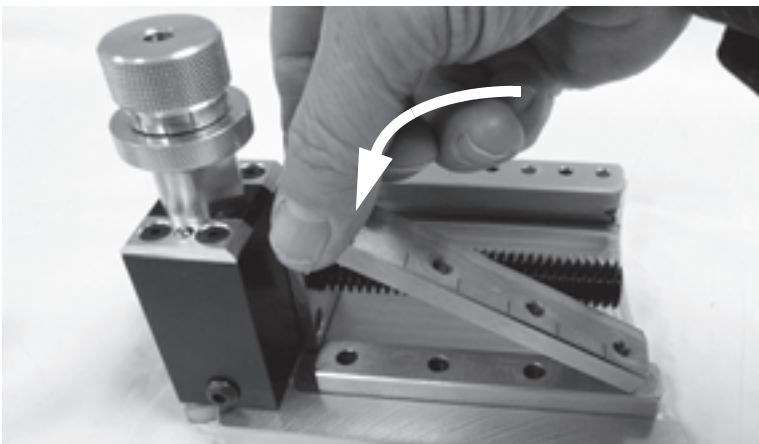

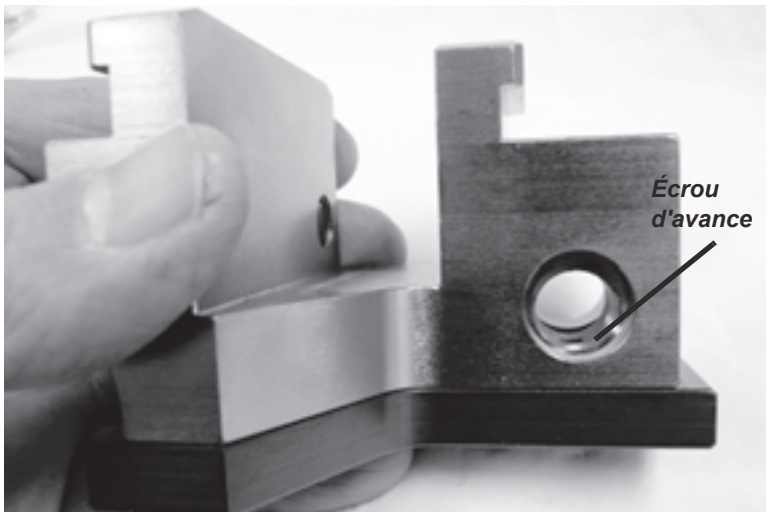
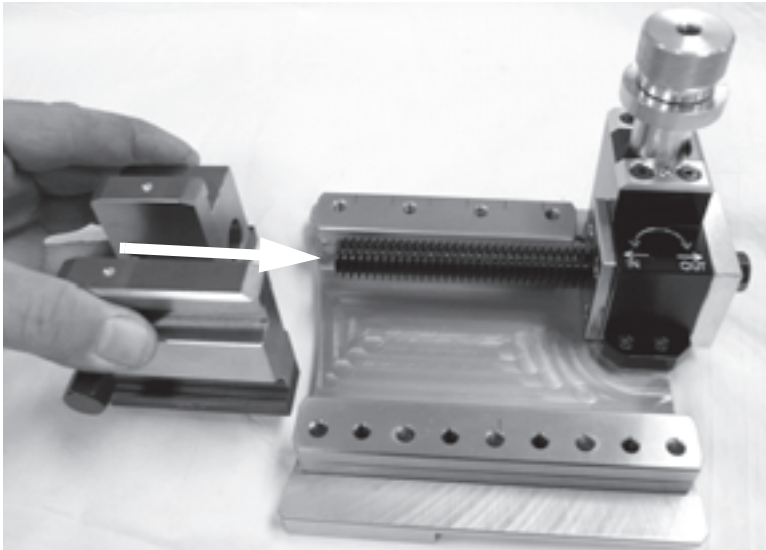

- 7.** Réinsérez le charriot à l'extrémité du plateau. Poussez le charriot de sorte à ce que la vis d'avance vienne se loger à l'intérieur du châssis.
 - L'écrou d'avance situé à l'intérieur du châssis peut bouger librement. Il se peut que vous ayez à le positionner pour engager les filetages dans la vis d'avance.
- 8.** Faites pivoter l'écrou à rétractation rapide en poussant le charriot en direction de la vis d'avance. Rétractez le plateau vers le centre.
 - 9.** Serrez les vis du rail du plateau, au niveau de la partie inférieure du plateau.



REMARQUE

Après avoir inversé les cache-rails, ajustez la tension du plateau en suivant la procédure décrite dans la rubrique « Réglage de la tension du plateau. » à la page 7.

Chapitre 3

Ensembles machine et rotor

Ce chapitre contient les dessins et listes de pièces pour les ensembles machines et rotors DynaPrep MDSF.

MDSF 6 po, 69-0000-06

ITEM	PART NUMBER	QTY	DESCRIPTION
1	60-096-00	1	CASE, STORAGE-1660 (NOT SHOWN)
2	60-129-00	2	PIN, FRAME LOCKING
3	60-711-00	1	PARTING TOOL, 1/4"
4	60-1274-00	2	TAG, LCSF
5	69-0049-00	4	LEG, 2.00"
6	69-0071-00	1	BAR, TRIP POSITIONING 6"- 24"
7	69-0134-06	1	LABEL, WEIGHT-MDSF 6"
8	69-0136-00	1	LABEL, CASE (NOT SHOWN)
9	69-0231-00	1	INSERT, FOAM 6" THRU 10" MDSF (NOT SHOWN)
10	69-0236-00	1	NAME PLATE
11	69-4000-06	1	6" ROTATING RING ASSEMBLY
12	69-4001-06	1	6" STATIONARY FRAME ASSEMBLY
13	69-4500-02	4	SCREW CLAMP ASSEMBLY 6" THRU 24", 2.00" STROKE
14	69-4800-00	4	EXTENSION LEG ASSEMBLY
15	69-4806-00	1	LASER ALIGNMENT TOOL
16	69-5503-00	1	KIT, MDSF 6" & 8" FASTENERS (NOT SHOWN)
17	69-5600-00	1	KIT, HAND TOOLS MDSF (NOT SHOWN)
18	69-7002-01	1	HOLDER KIT, 37.5 DEG. INSIDE BEVEL
19	69-7002-02	1	INSERT, INSIDE BEVEL
20	69-LIT-01	1	TOOLING CHART, MDSF (NOT SHOWN)
21	69-LIT-02	1	TOOLING CONFIGURATION CHART, MDSF (NOT SHOWN)
22	69-MAN-01	1	MANUAL, MDSF (NOT SHOWN)
23	69-MAN-02	1	MANUAL, MDSF MAINTENANCE (NOT SHOWN)
24	90-049-06	4	SCREW, #2-3/16 U-DRIVE
25	90-400-03	1	WACHS CIRCLE LOGO 8" (NOT SHOWN)
26	90-404-00	1	LABEL, GENERAL PRODUCTS (NOT SHOWN)
27	90-1010-16	1	SHCS, M8 X 1.25MM X 16MM

REV B

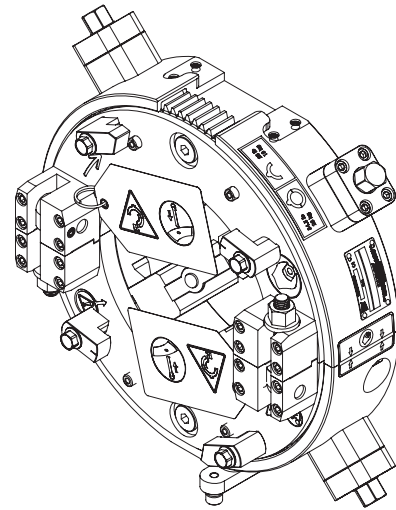

NOTES:

1. WIPER REQUIRE WAY OIL (PART NO.: 60-1184-00) SOLD SEPARATELY.
2. SHIPPING DIMENSIONS: 31.59 [802.4 mm] LENGTH X 22.99 [583.9 mm] WIDTH X 19.48 [494.8 mm] HEIGHT

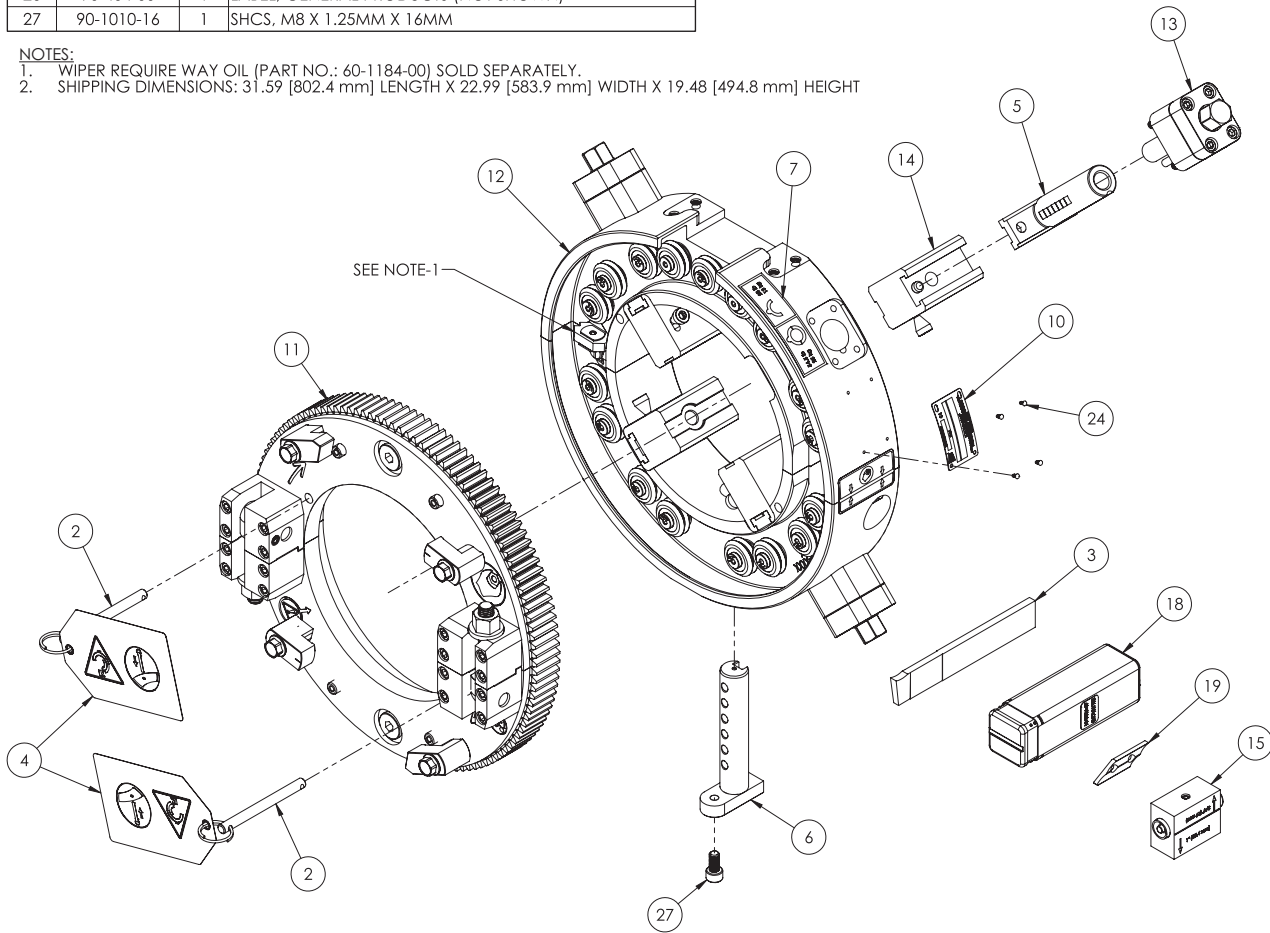

MDSF 8 po, 69-0000-08

ITEM	PART NUMBER	QTY	DESCRIPTION
1	60-096-00	1	CASE, STORAGE-1660 (NOT SHOWN)
2	60-129-00	2	PIN, FRAME LOCKING
3	60-711-00	1	PARTING TOOL, 1/4"
4	60-1274-00	2	TAG, LCSF
5	69-0049-00	4	LEG, 2.00"
6	69-0071-00	1	BAR, TRIP POSITIONING 6'- 24"
7	69-0134-08	1	LABEL, WEIGHT-MDSF 8"
8	69-0136-00	1	LABEL, CASE (NOT SHOWN)
9	69-0231-00	1	INSERT, FOAM 6" THRU 10" MDSF (NOT SHOWN)
10	69-0236-00	1	NAME PLATE
11	69-4000-08	1	8" ROTATING RING ASSEMBLY
12	69-4001-08	1	8" STATIONARY FRAME ASSEMBLY
13	69-4500-02	4	SCREW CLAMP ASSEMBLY 6" THRU 24", 2.00" STROKE
14	69-4800-00	4	EXTENSION LEG ASSEMBLY
15	69-4806-00	1	LASER ALIGNMENT TOOL
16	69-5503-00	1	KIT, MDSF 6" & 8" FASTENERS (NOT SHOWN)
17	69-5600-00	1	KIT, HAND TOOLS MDSF (NOT SHOWN)
18	69-7002-03	1	HOLDER KIT, 37.5 DEG. INSIDE BEVEL
19	69-7002-02	1	INSERT, INSIDE BEVEL
20	69-LIT-01	1	TOOLING CHART, MDSF (NOT SHOWN)
21	69-LIT-02	1	TOOLING CONFIGURATION CHART, MDSF (NOT SHOWN)
22	69-MAN-01	1	MANUAL, MDSF (NOT SHOWN)
23	69-MAN-02	1	MANUAL, MDSF MAINTENANCE (NOT SHOWN)
24	90-049-06	4	SCREW, #2-3/16 U-DRIVE
25	90-400-03	1	WACHS CIRCLE LOGO 8" (NOT SHOWN)
26	90-404-00	1	LABEL, GENERAL PRODUCTS (NOT SHOWN)
27	90-1010-16	1	SHCS, M8 X 1.25MM X 16MM

Rev B

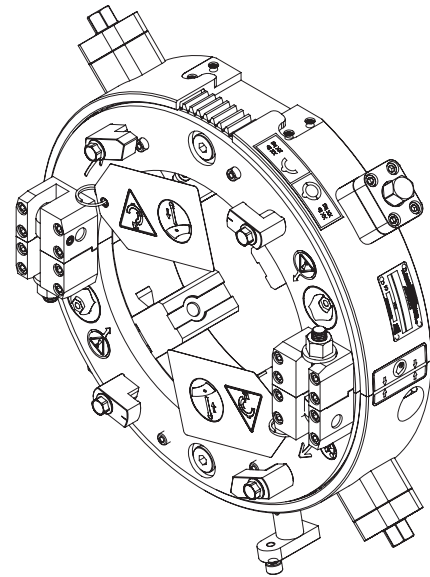

NOTES:

1. WIPER REQUIRE WAY OIL (PART NO.: 60-1184-00) SOLD SEPARATELY.
2. SHIPPING DIMENSIONS: 31.59 [802.4 mm] LENGTH X 22.99 [583.9 mm] WIDTH X 19.48 [494.8 mm] HEIGHT

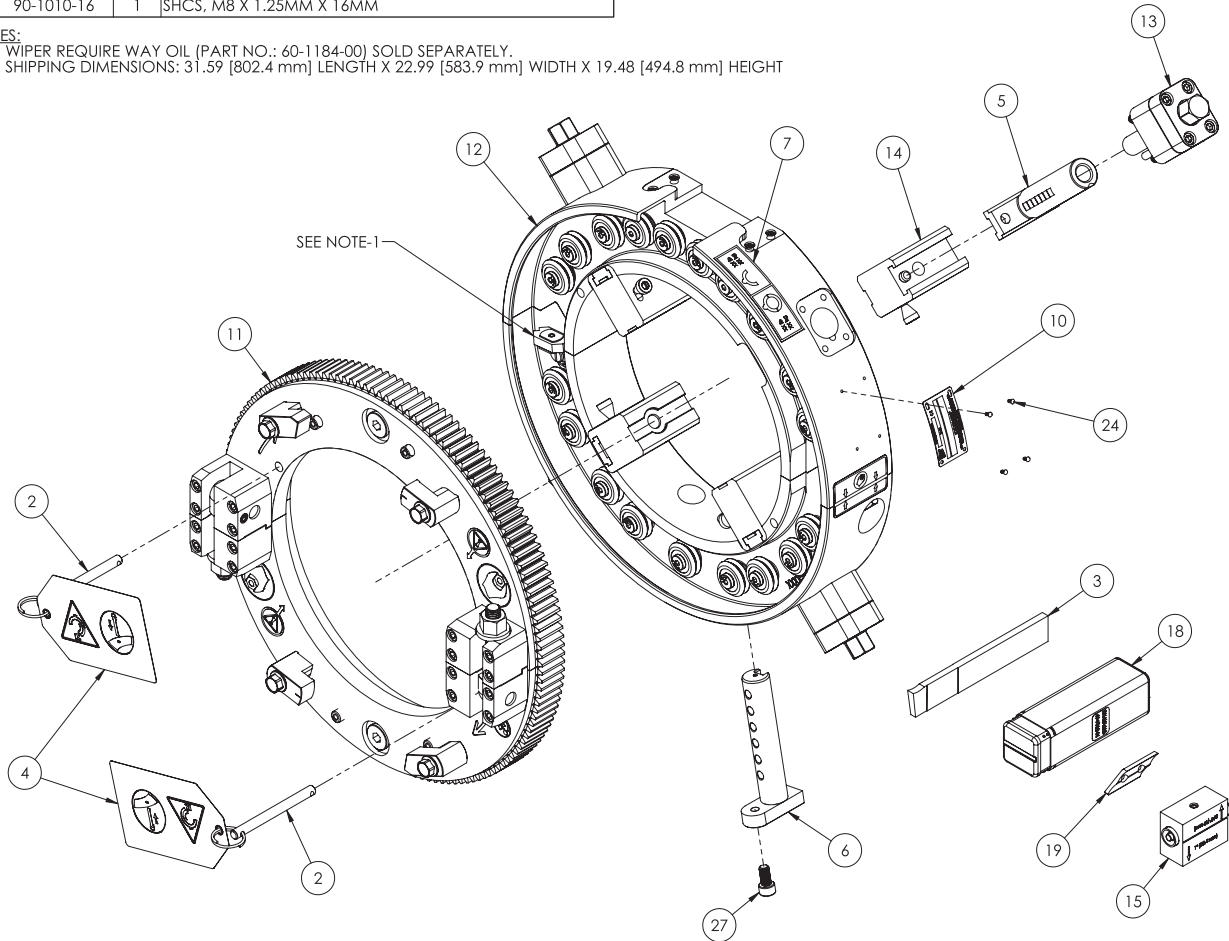

MDSF 10 po, 69-0000-10

ITEM	PART NUMBER	QTY	DESCRIPTION
1	60-096-00	1	CASE, STORAGE-1660 (NOT SHOWN)
2	60-129-00	2	PIN, FRAME LOCKING
3	60-711-00	1	PARTING TOOL, 1/4"
4	60-1274-00	2	TAG, LCSF
5	69-0049-00	4	LEG, 2.00"
6	69-0071-00	1	BAR, TRIP POSITIONING 6"- 24"
7	69-0134-10	1	LABEL, WEIGHT-MDSF 10"
8	69-0136-00	1	LABEL, CASE (NOT SHOWN)
9	69-0231-00	1	INSERT, FOAM 6" THRU 10" MDSF (NOT SHOWN)
10	69-0236-00	1	NAME PLATE
11	69-4000-10	1	10" ROTATING RING ASSEMBLY
12	69-4001-10	1	10" STATIONARY FRAME ASSEMBLY
13	69-4500-02	4	SCREW CLAMP ASSEMBLY 6" THRU 24", 2.00" STROKE
14	69-4800-00	4	EXTENSION LEG ASSEMBLY
15	69-4806-00	1	LASER ALIGNMENT TOOL
16	69-5500-00	1	KIT, MDSF 10"-24" FASTENERS (NOT SHOWN)
17	69-5600-00	1	KIT, HAND TOOLS MDSF (NOT SHOWN)
18	69-7002-03	1	HOLDER KIT, 37.5 DEG. INSIDE BEVEL
19	69-7002-02	1	INSERT, INSIDE BEVEL
20	69-LIT-01	1	TOOLING CHART, MDSF (NOT SHOWN)
21	69-LIT-02	1	TOOLING CONFIGURATION CHART, MDSF (NOT SHOWN)
22	69-MAN-01	1	MANUAL, MDSF (NOT SHOWN)
23	69-MAN-02	1	MANUAL, MDSF MAINTENANCE (NOT SHOWN)
24	90-049-06	4	SCREW, #2-3/16 U-DRIVE
25	90-400-03	1	WACHS CIRCLE LOGO 8" (NOT SHOWN)
26	90-404-00	1	LABEL, GENERAL PRODUCTS (NOT SHOWN)
27	90-1010-16	1	SHCS, M8 X 1.25MM X 16MM

Rev C

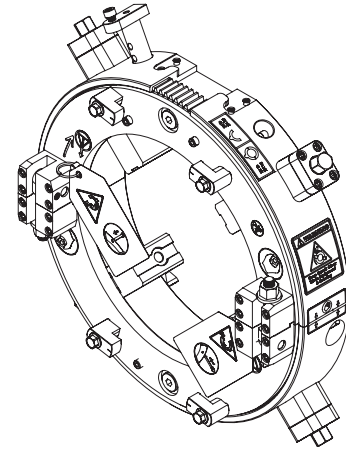

NOTES:

1. WIPER REQUIRE WAY OIL (PART NO.: 60-1184-00) SOLD SEPARATELY.
2. SHIPPING DIMENSIONS: 31.59 [802.4 mm] LENGTH X 22.99 [583.9 mm] WIDTH X 19.48 [494.8 mm] HEIGHT

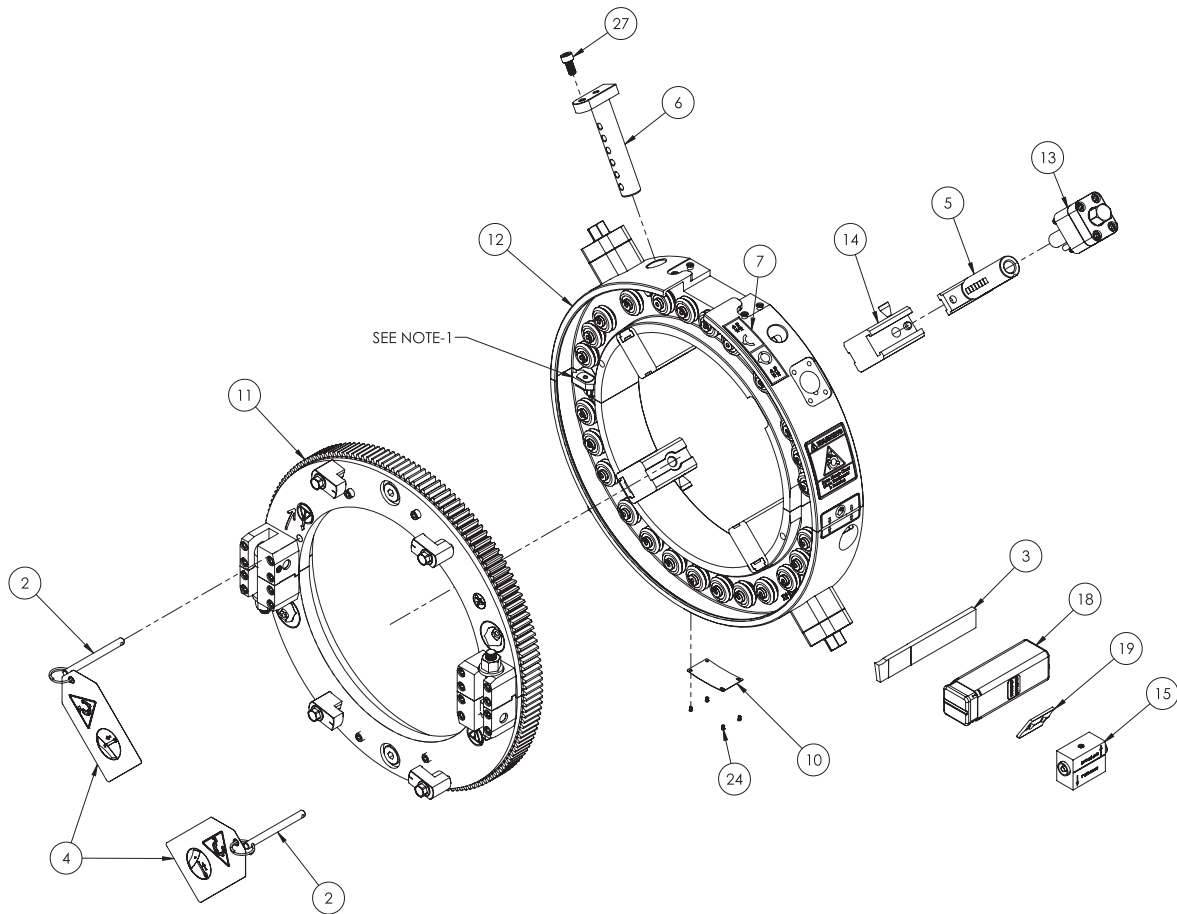

MDSF 12 po, 69-0000-12

ITEM	PART NUMBER	QTY	DESCRIPTION
1	60-096-00	1	CASE, STORAGE-1660 (NOT SHOWN)
2	60-129-00	2	PIN, FRAME LOCKING
3	60-711-00	1	PARTING TOOL, 1/4"
4	60-1274-00	2	TAG, LCSF
5	69-0049-00	4	LEG, 2.00"
6	69-0071-00	1	BAR, TRIP POSITIONING 6'- 24"
7	69-0132-00	1	INSERT, FOAM 12 THRU 16 MDSF (NOT SHOWN)
8	69-0136-00	1	LABEL, CASE (NOT SHOWN)
9	69-0236-00	1	NAME PLATE
10	69-4000-12	1	12" ROTATING RING ASSEMBLY
11	69-4001-12	1	12" STATIONARY FRAME ASSEMBLY
12	69-4500-02	4	SCREW CLAMP ASSEMBLY 6" THRU 24", 2.00" STROKE
13	69-4800-00	4	EXTENSION LEG ASSEMBLY
14	69-4806-00	1	LASER ALIGNMENT TOOL
15	69-5500-00	1	KIT, MDSF 10"-24" FASTENERS (NOT SHOWN)
16	69-5600-00	1	KIT, HAND TOOLS MDSF (NOT SHOWN)
17	69-7002-01	1	HOLDER KIT, 37.5 DEG. INSIDE BEVEL
18	69-7002-02	1	INSERT, INSIDE BEVEL
19	69-LIT-01	1	TOOLING CHART, MDSF (NOT SHOWN)
20	69-LIT-02	1	TOOLING CONFIGURATION CHART, MDSF (NOT SHOWN)
21	69-MAN-01	1	MANUAL, MDSF (NOT SHOWN)
22	69-MAN-02	1	MANUAL, MDSF MAINTENANCE (NOT SHOWN)
23	90-049-06	4	SCREW, #2-3/16 U-DRIVE
24	90-400-03	1	WACHS CIRCLE LOGO 8" (NOT SHOWN)
25	90-404-00	1	LABEL, GENERAL PRODUCTS (NOT SHOWN)
26	90-1010-16	1	SHCS, M8 X 1.25MM X 16MM
27	69-0134-12	1	LABEL, WEIGHT-MDSF 12"

Rev D

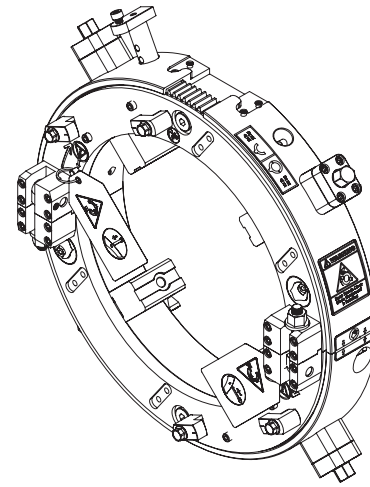

NOTES:

1. WIPER REQUIRE WAY OIL (PART NO.: 60-1184-00) SOLD SEPARATELY.
2. SHIPPING DIMENSIONS: 31.59 [802.4 mm] LENGTH X 22.99 [583.9 mm] WIDTH X 19.48 [494.8 mm] HEIGHT

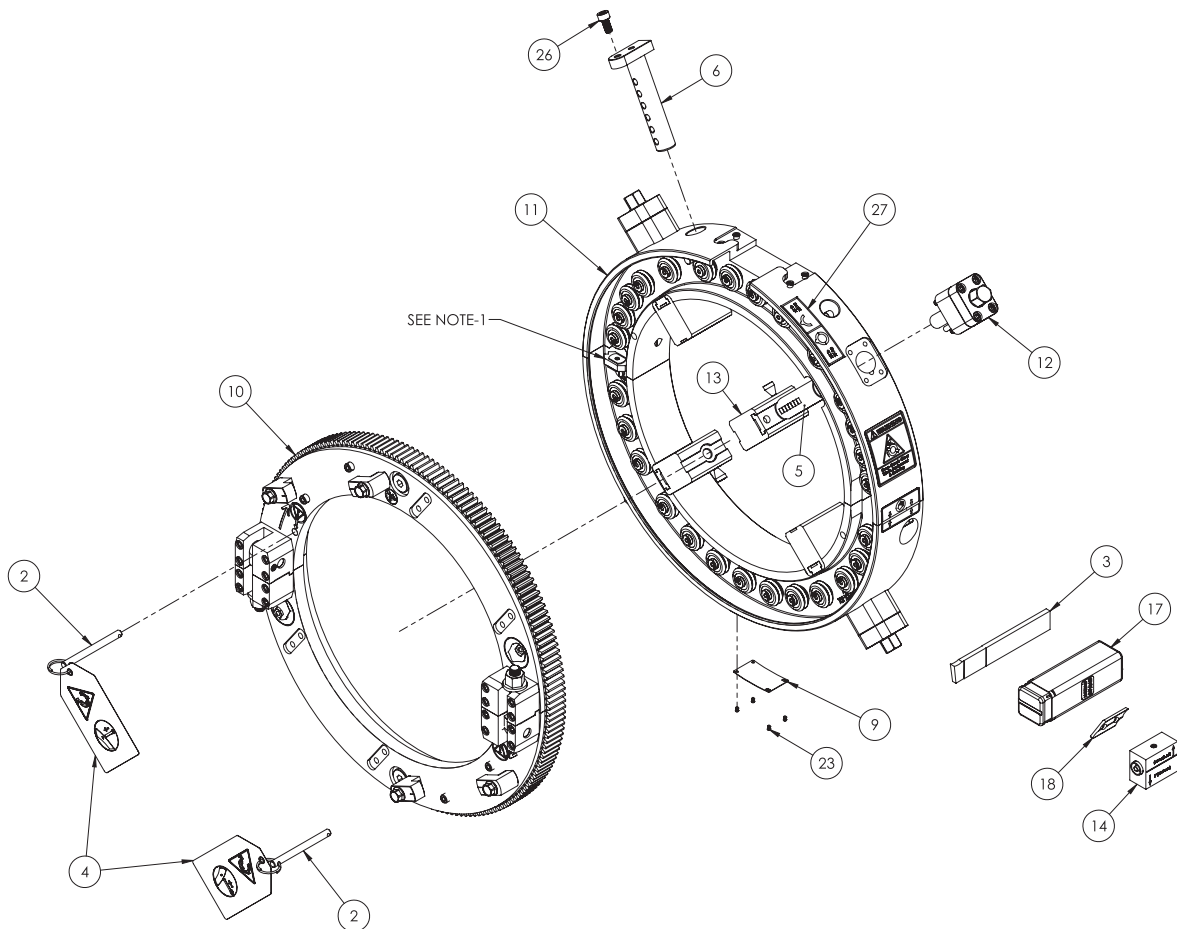

MDSF 14 po, 69-0000-14

ITEM	PART NUMBER	QTY	DESCRIPTION
1	60-096-00	1	CASE, STORAGE-1660 (NOT SHOWN)
2	60-129-00	2	PIN, FRAME LOCKING
3	60-711-00	1	PARTING TOOL, 1/4"
4	60-1274-00	2	TAG, LCSF
5	69-0049-00	4	LEG, 2.00"
6	69-0071-00	1	BAR, TRIP POSITIONING 6"- 24"
7	69-0132-00	1	INSERT, FOAM 12 THRU 16 MDSF (NOT SHOWN)
8	69-0134-14	1	LABEL, WEIGHT-MDSF 14"
9	69-0136-00	1	LABEL, CASE (NOT SHOWN)
10	69-0236-00	1	NAME PLATE
11	69-4000-14	1	14" ROTATING RING ASSEMBLY
12	69-4001-14	1	14" STATIONARY FRAME ASSEMBLY
13	69-4500-02	4	SCREW CLAMP ASSEMBLY 6" THRU 24", 2.00" STROKE
14	69-4800-00	4	EXTENSION LEG ASSEMBLY
15	69-4806-00	1	LASER ALIGNMENT TOOL
16	69-5500-00	1	KIT, MDSF FASTENERS (NOT SHOWN)
17	69-5600-00	1	KIT, HAND TOOLS MDSF (NOT SHOWN)
18	69-7002-03	1	HOLDER KIT, 37.5 DEG. INSIDE BEVEL
19	69-7002-02	1	INSERT, INSIDE BEVEL
20	69-LIT-01	1	TOOLING CHART, MDSF (NOT SHOWN)
21	69-LIT-02	1	TOOLING CONFIGURATION CHART, MDSF (NOT SHOWN)
22	69-MAN-01	1	MANUAL, MDSF (NOT SHOWN)
23	69-MAN-02	1	MANUAL, MDSF MAINTENANCE (NOT SHOWN)
24	90-049-06	4	SCREW, #2-3/16 U-DRIVE
25	90-400-03	1	WACHS CIRCLE LOGO 8" (NOT SHOWN)
26	90-404-00	1	LABEL, GENERAL PRODUCTS (NOT SHOWN)
27	90-1010-16	1	SHCS, M8 X 1.25MM X 16MM

Rev E

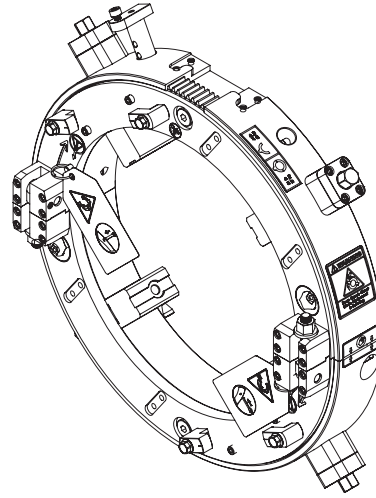

NOTES:

1. WIPER REQUIRE WAY OIL (PART NO.: 60-1184-00) SOLD SEPARATELY.
2. SHIPPING DIMENSIONS: 31.59 [802.4 mm] LENGTH X 22.99 [583.9 mm] WIDTH X 19.48 [494.8 mm] HEIGHT

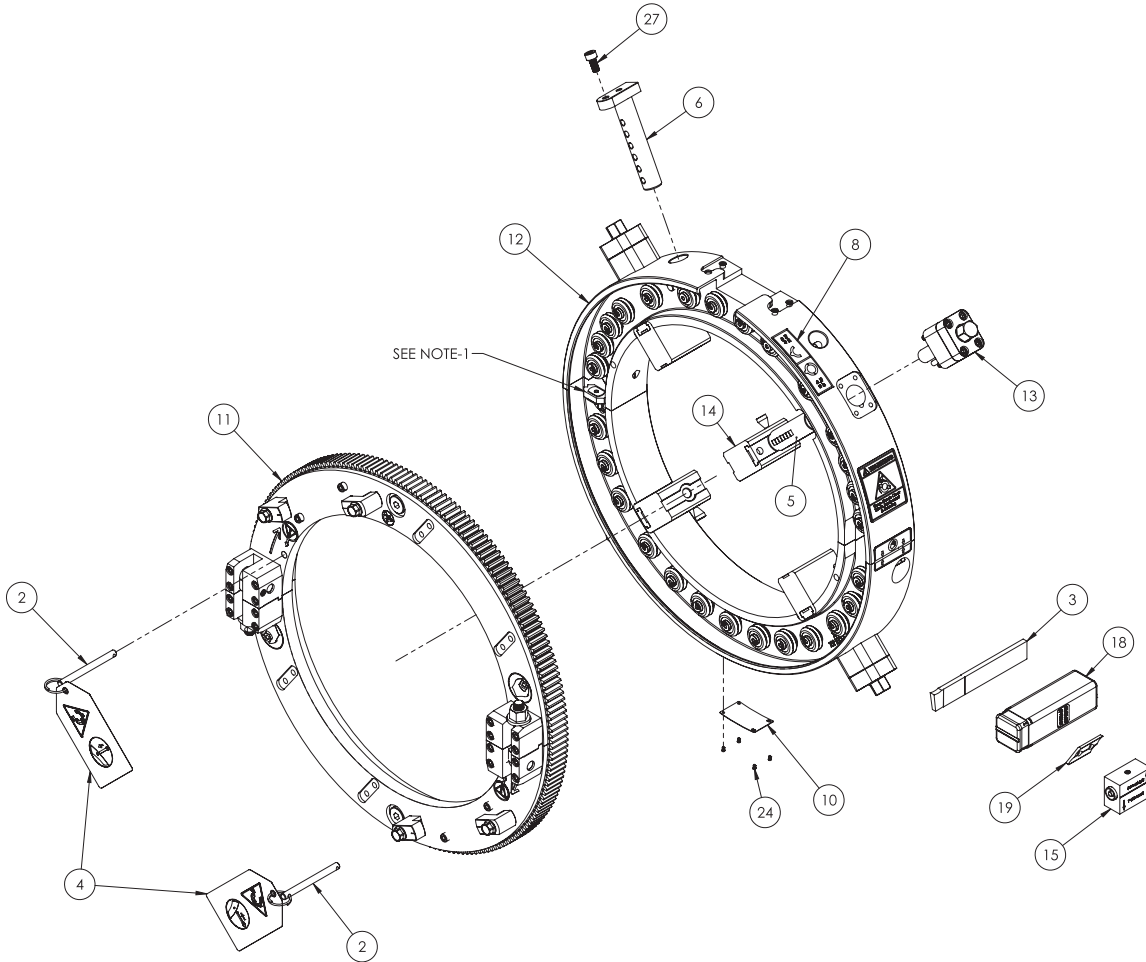

MDSF 16 po, 69-0000-16

ITEM	PART NUMBER	QTY	DESCRIPTION
1	60-096-00	1	CASE, STORAGE-1660 (NOT SHOWN)
2	60-129-00	2	PIN, FRAME LOCKING
3	60-711-00	1	PARTING TOOL, 1/4"
4	60-1274-00	2	TAG, LCSF
5	69-0049-00	4	LEG, 2.00"
6	69-0071-00	1	BAR, TRIP POSITIONING 6"- 24"
7	69-0132-00	1	INSERT, FOAM 12 THRU 16 MDSF (NOT SHOWN)
8	69-0134-16	1	LABEL, WEIGHT-MDSF 16"
9	69-0136-00	1	LABEL, CASE (NOT SHOWN)
10	69-0236-00	1	NAME PLATE
11	69-4000-16	1	16" ROTATING RING ASSEMBLY
12	69-4001-16	1	16" STATIONARY FRAME ASSEMBLY
13	69-4500-02	4	SCREW CLAMP ASSEMBLY 6" THRU 24", 2.00" STROKE
14	69-4800-00	4	EXTENSION LEG ASSEMBLY
15	69-4806-00	1	LASER ALIGNMENT TOOL
16	69-5500-00	1	KIT, MDSF 10"-24" FASTENERS (NOT SHOWN)
17	69-5600-00	1	KIT, HAND TOOLS MDSF (NOT SHOWN)
18	69-7002-01	1	HOLDER KIT, 37.5 DEG. INSIDE BEVEL
19	69-7002-02	1	INSERT, INSIDE BEVEL
20	69-LIT-01	1	TOOLING CHART, MDSF (NOT SHOWN)
21	69-LIT-02	1	TOOLING CONFIGURATION CHART, MDSF (NOT SHOWN)
22	69-MAN-01	1	MANUAL, MDSF (NOT SHOWN)
23	69-MAN-02	1	MANUAL, MDSF MAINTENANCE (NOT SHOWN)
24	90-049-06	4	SCREW, #2-3/16 U-DRIVE
25	90-400-03	1	WACHS CIRCLE LOGO 8" (NOT SHOWN)
26	90-404-00	1	LABEL, GENERAL PRODUCTS (NOT SHOWN)
27	90-1010-16	1	SHCS, M8 X 1.25MM X 16MM

Rev D

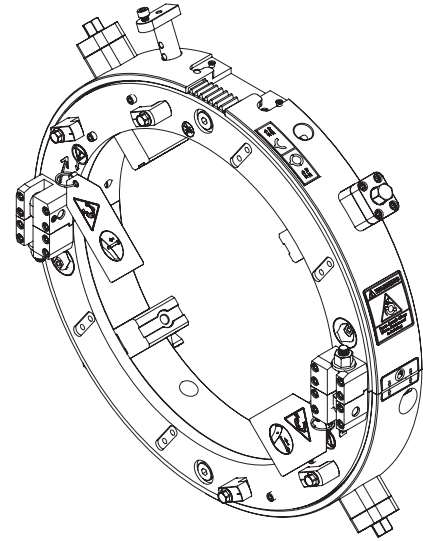

- NOTES:
 1. WIPER REQUIRE WAY OIL (PART NO.: 60-1184-00) SOLD SEPARATELY.
 2. SHIPPING DIMENSIONS: 31.59 [802.4 mm] LENGTH X 22.99 [583.9 mm] WIDTH X 19.48 [494.8 mm] HEIGHT

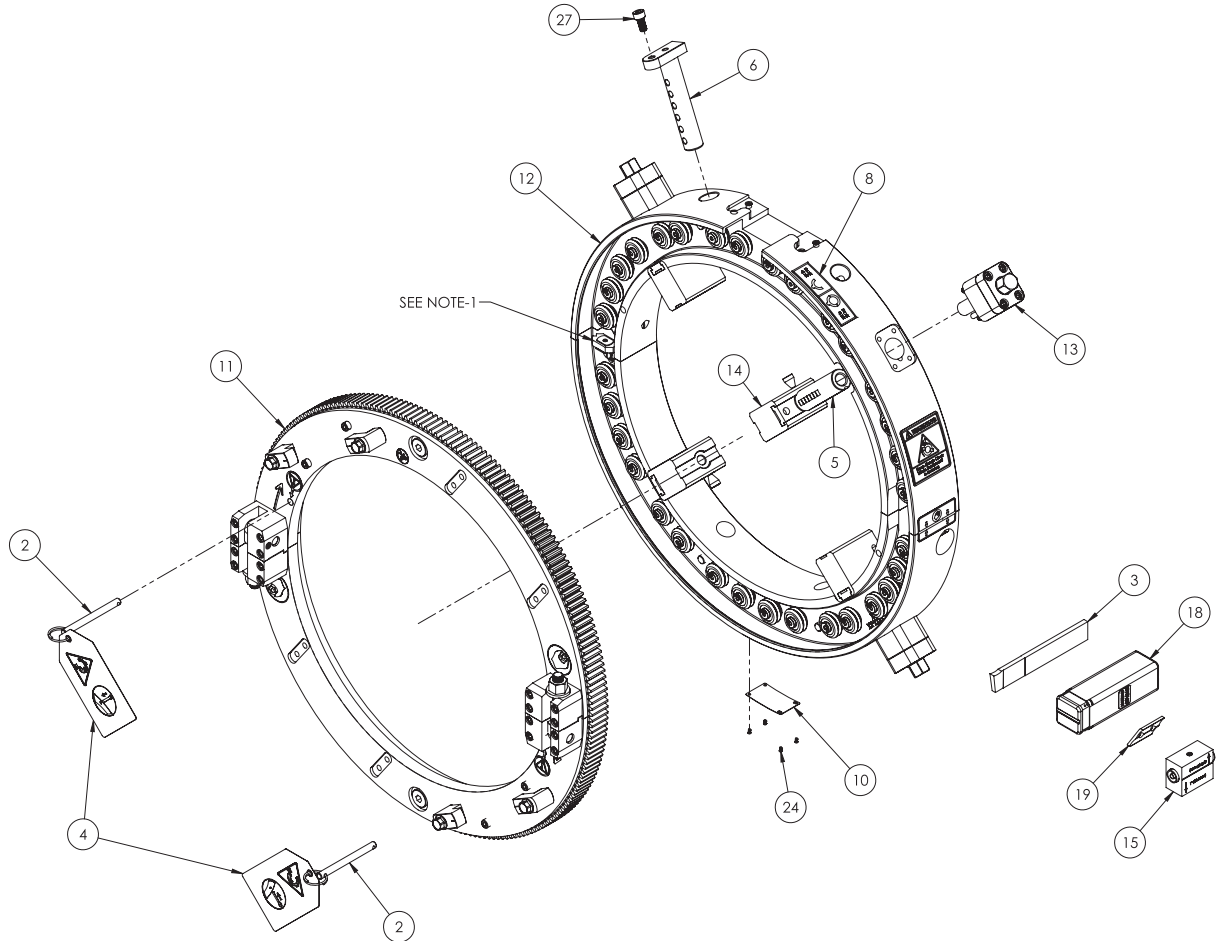

MDSF 18 po, 69-0000-18

ITEM	PART NUMBER	QTY	DESCRIPTION
1	60-096-00	1	CASE, STORAGE-1660 (NOT SHOWN)
2	60-129-00	2	PIN, FRAME LOCKING
3	60-711-00	1	PARTING TOOL, 1/4"
4	60-1274-00	2	TAG, LCSF
5	69-0049-00	4	LEG, 2.00"
6	69-0071-00	1	BAR, TRIP POSITIONING 6"- 24"
7	69-0133-00	1	INSERT, FOAM 18 AND 20 MDSF (NOT SHOWN)
8	69-0134-18	1	LABEL, WEIGHT-MDSF 18"
9	69-0136-00	1	LABEL, CASE (NOT SHOWN)
10	69-0236-00	1	NAME PLATE
11	69-4000-18	1	18" ROTATING RING ASSEMBLY
12	69-4001-18	1	18" STATIONARY FRAME ASSEMBLY
13	69-4500-02	4	SCREW CLAMP ASSEMBLY 6" THRU 24", 2.00" STROKE
14	69-4800-00	4	EXTENSION LEG ASSEMBLY
15	69-4806-00	1	LASER ALIGNMENT TOOL
16	69-5500-00	1	KIT, MDSF 10'-24" FASTENERS (NOT SHOWN)
17	69-5600-00	1	KIT, HAND TOOLS MDSF (NOT SHOWN)
18	69-7002-01	1	HOLDER KIT, 37.5 DEG. INSIDE BEVEL
19	69-7002-02	1	INSERT, INSIDE BEVEL
20	69-LIT-01	1	TOOLING CHART, MDSF (NOT SHOWN)
21	69-LIT-02	1	TOOLING CONFIGURATION CHART, MDSF (NOT SHOWN)
22	69-MAN-01	1	MANUAL, MDSF (NOT SHOWN)
23	69-MAN-02	1	MANUAL, MDSF MAINTENANCE (NOT SHOWN)
24	90-049-06	4	SCREW, #2-3/16 U-DRIVE
25	90-400-03	1	WACHS CIRCLE LOGO 8" (NOT SHOWN)
26	90-404-00	1	LABEL, GENERAL PRODUCTS (NOT SHOWN)
27	90-1010-16	1	SHCS, M8 X 1.25MM X 16MM
28	90-1028-00	4	EYE BOLT, M14 X 2

REV D

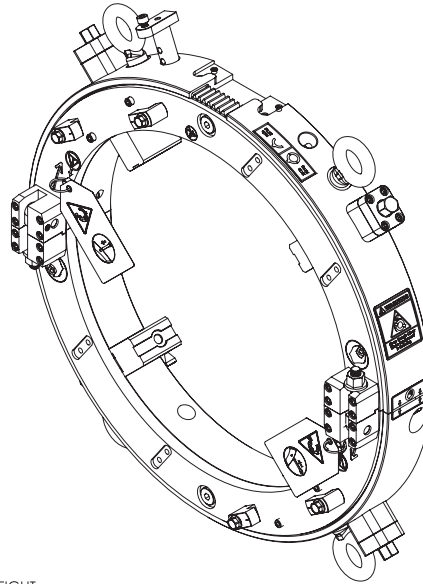

NOTES:

1. WIPER REQUIRE WAY OIL (PART NO.: 60-1184-00) SOLD SEPARATELY.
2. SHIPPING DIMENSIONS: 31.59 [802.4 mm] LENGTH X 22.99 [583.9 mm] WIDTH X 19.48 [494.8 mm] HEIGHT

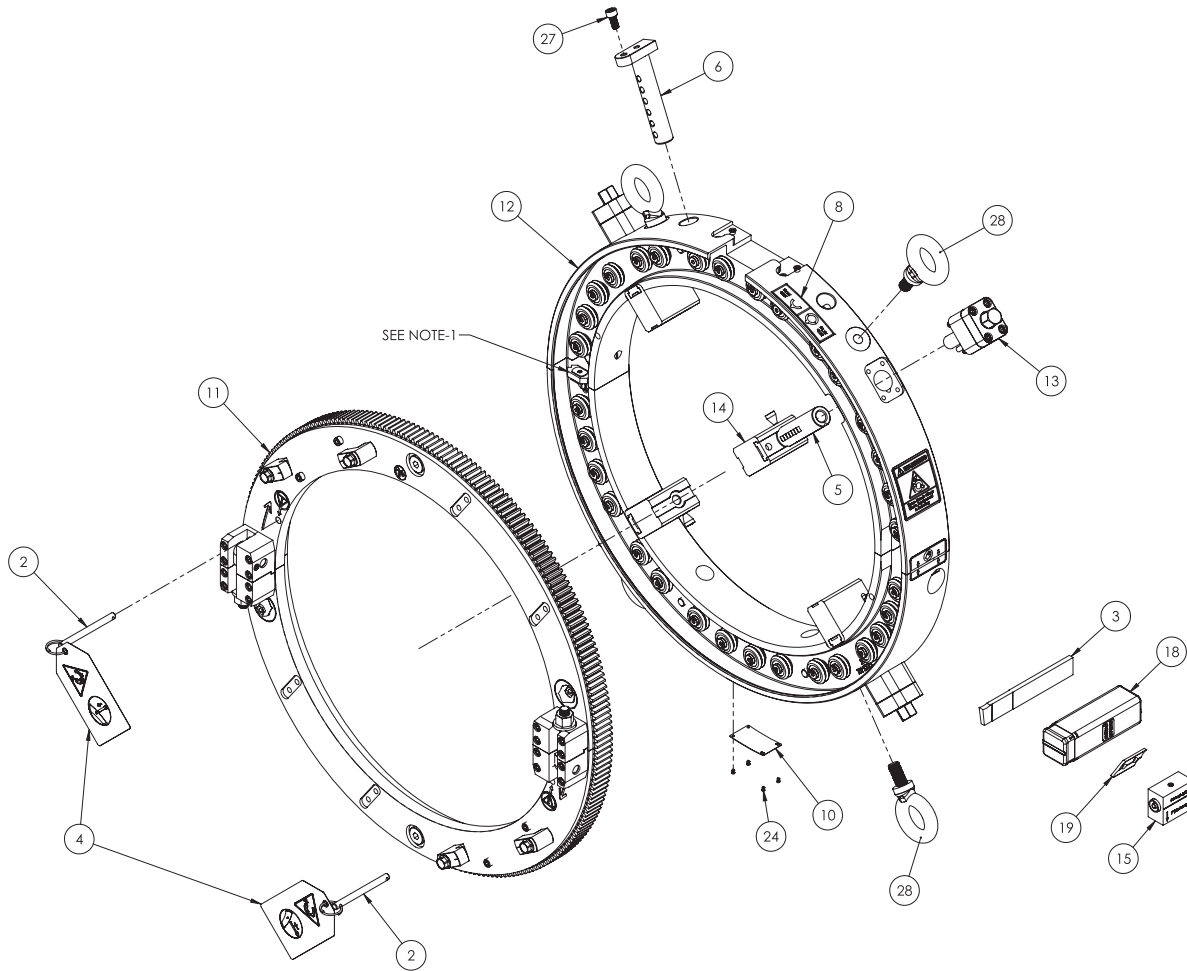

MDSF 20 po, 69-0000-20

ITEM	PART NUMBER	QTY	DESCRIPTION
1	60-094-00	1	CASE, STORAGE-1660 (NOT SHOWN)
2	60-129-00	2	PIN, FRAME LOCKING
3	60-711-00	1	PARTING TOOL, 1/4"
4	60-1274-00	2	TAG, LCSF
5	69-0049-00	4	LEG, 2.00"
6	69-0071-00	1	BAR, TRIP POSITIONING 6'- 24"
7	69-0133-00	1	INSERT, FOAM 18 AND 20 MDSF (NOT SHOWN)
8	69-0134-20	1	LABEL, WEIGHT-MDSF 20"
9	69-0136-00	1	LABEL, CASE (NOT SHOWN)
10	69-0236-00	1	NAME PLATE
11	69-4000-20	1	20" ROTATING RING ASSEMBLY
12	69-4001-20	1	20" STATIONARY FRAME ASSEMBLY
13	69-4500-02	4	SCREW CLAMP ASSEMBLY 6" THRU 24", 2.00" STROKE
14	69-4800-00	4	EXTENSION LEG ASSEMBLY
15	69-4806-00	1	LASER ALIGNMENT TOOL
16	69-5500-00	1	KIT, MDSF 10'-24" FASTENERS (NOT SHOWN)
17	69-5600-00	1	KIT, HAND TOOLS MDSF (NOT SHOWN)
18	69-7002-01	1	HOLDER KIT, 37.5 DEG. INSIDE BEVEL
19	69-7002-02	1	INSERT, INSIDE BEVEL
20	69-LIT-01	1	TOOLING CHART, MDSF (NOT SHOWN)
21	69-LIT-02	1	TOOLING CONFIGURATION CHART, MDSF (NOT SHOWN)
22	69-MAN-01	1	MANUAL, MDSF (NOT SHOWN)
23	69-MAN-02	1	MANUAL, MDSF MAINTENANCE (NOT SHOWN)
24	90-049-06	4	SCREW, #2-3/16 U-DRIVE
25	90-400-03	1	WACHS CIRCLE LOGO 8" (NOT SHOWN)
26	90-404-00	1	LABEL, GENERAL PRODUCTS (NOT SHOWN)
27	90-1010-16	1	SHCS, M8 X 1.25MM X 16MM
28	90-1028-00	4	EYE BOLT, M14 X 2

Rev D

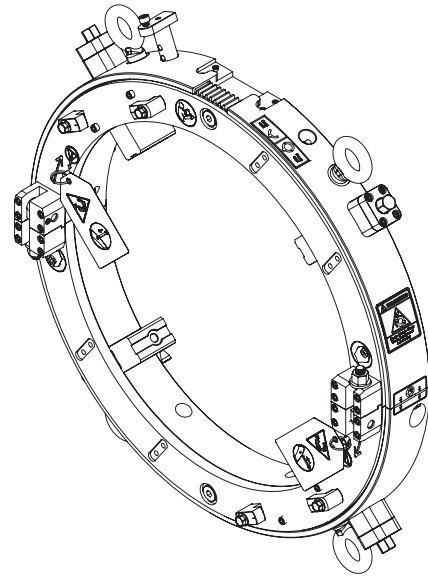

- NOTES:
 1. WIPER REQUIRE WAY OIL (PART NO.: 60-1184-00) SOLD SEPARATELY.
 2. SHIPPING DIMENSIONS: 31.59 [802.4 mm] LENGTH X 22.99 [583.9 mm] WIDTH X 19.48 [494.8 mm] HEIGHT

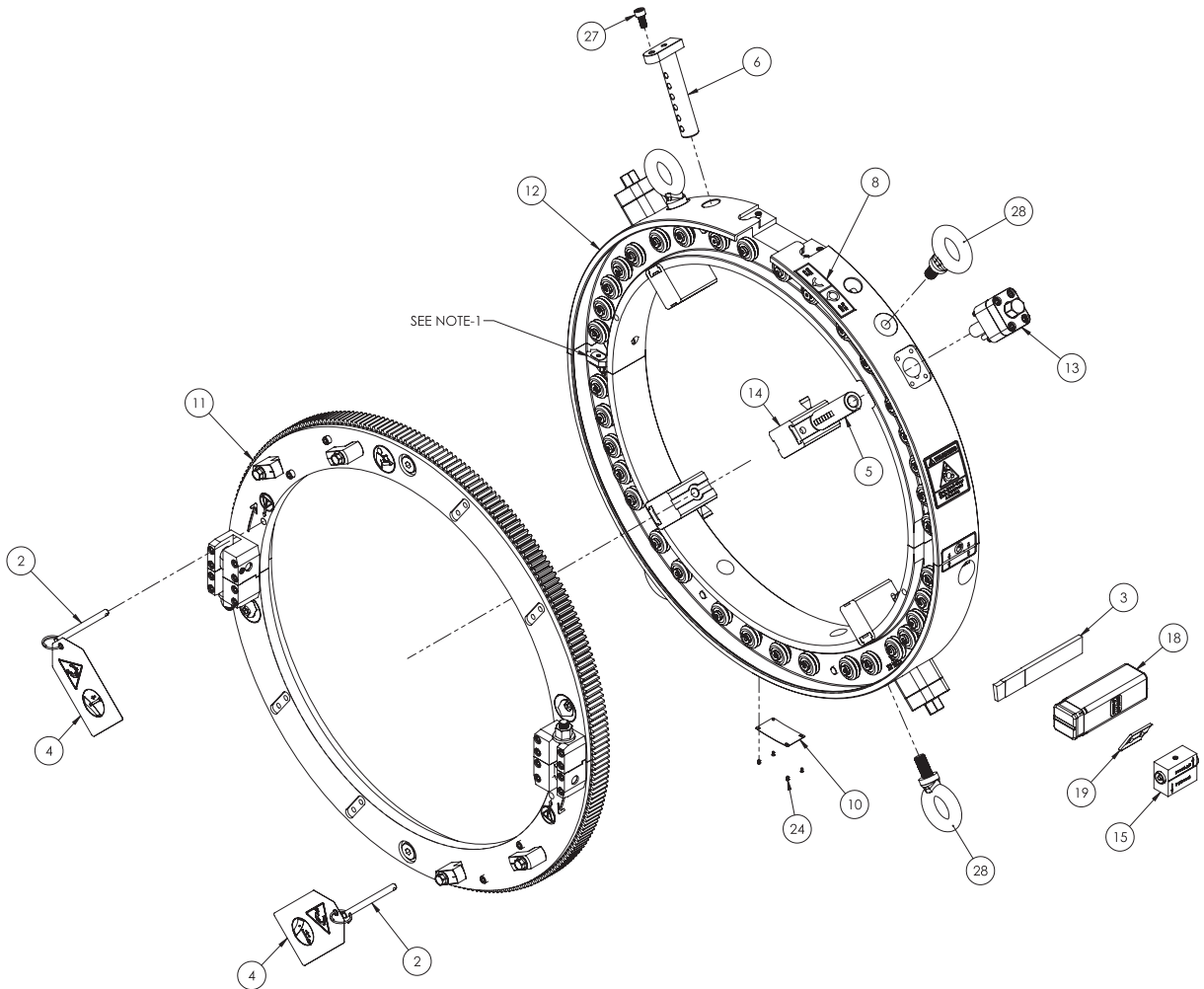

MDSF 24 po, 69-0000-24

ITEM	PART NUMBER	QTY	DESCRIPTION
1	60-129-00	2	PIN, FRAME LOCKING
2	60-711-XX	1	PARTING TOOL, 1/4"
3	60-1274-00	2	TAG, LCSF
4	69-0049-00	4	LEG, 2.00"
5	69-0071-00	1	BAR, TRIP POSITIONING 6"- 24"
6	69-0134-24	1	LABEL, WEIGHT-MDSF 24"
7	69-0136-00	1	LABEL, CASE (NOT SHOWN)
8	69-0148-00	1	INSERT, FOAM 24"-36" MDSF (NOT SHOWN)
9	69-0149-00	1	CASE, STORAGE 24"-36" MDSF (NOT SHOWN)
10	69-0236-00	1	NAME PLATE
11	69-4000-24	1	24" ROTATING RING ASSEMBLY
12	69-4001-24	1	24" STATIONARY FRAME ASSEMBLY
13	69-4500-02	4	SCREW CLAMP ASSEMBLY 6" THRU 24", 2.00" STROKE
14	69-4501-00	4	LEG SCREW ASSEMBLY, SHORT
15	69-4800-00	4	EXTENSION LEG ASSEMBLY
16	69-4806-00	1	LASER ALIGNMENT TOOL
17	69-5500-00	1	KIT, MDSF 10"-24" FASTENERS (NOT SHOWN)
18	69-5600-00	1	KIT, HAND TOOLS MDSF (NOT SHOWN)
19	69-7002-01	1	HOLDER KIT, 37.5 DEG. INSIDE BEVEL
20	69-7002-02	1	INSERT, INSIDE BEVEL
21	69-LIT-01	1	TOOLING CHART, MDSF (NOT SHOWN)
22	69-LIT-02	1	TOOLING CONFIGURATION CHART, MDSF (NOT SHOWN)
23	69-MAN-01	1	MANUAL, MDSF (NOT SHOWN)
24	69-MAN-02	1	MANUAL, MDSF MAINTENANCE (NOT SHOWN)
25	90-049-06	4	SCREW, #2-3/16 U-DRIVE
26	90-400-04	1	WACHS CIRCLE LOGO 12" (NOT SHOWN)
27	90-404-00	1	LABEL, GENERAL PRODUCTS (NOT SHOWN)
28	90-1010-16	1	SHCS, M8 X 1.25MM X 16MM
29	90-1028-00	4	EYE BOLT, M14 X 2

Rev D

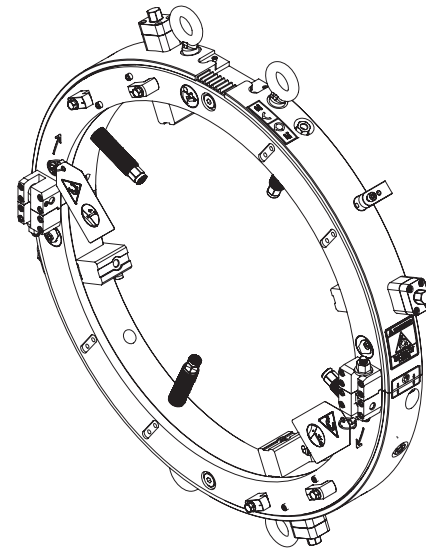

NOTES:

1. WIPER REQUIRE WAY OIL (PART NO.: 60-1184-00) SOLD SEPARATELY.
2. SHIPPING DIMENSIONS: TBD [TBD mm] LENGTH X TBD [TBD mm] WIDTH X TBD [TBD mm] HEIGHT

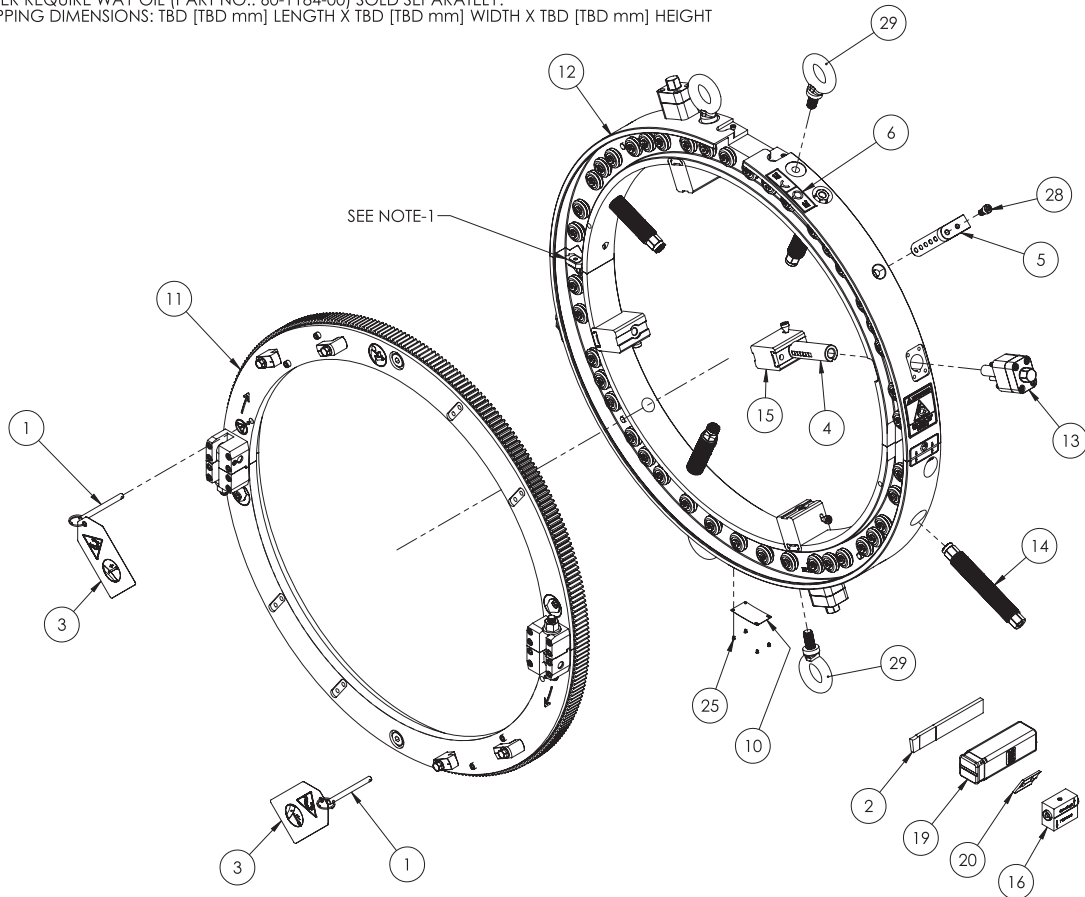

MDSF 28 po, 69-0000-28

ITEM	PART NUMBER	QTY	DESCRIPTION
1	60-129-00	2	PIN, FRAME LOCKING
2	60-711-00	1	PARTING TOOL, 1/4"
3	60-1274-00	2	TAG, LCSF
4	69-0049-00	4	LEG, 2.00"
5	69-0134-28	1	LABEL, WEIGHT-MDSF 28"
6	69-0136-00	1	LABEL, CASE (NOT SHOWN)
7	69-0148-00	1	INSERT, FOAM 24"-36" MDSF (NOT SHOWN)
8	69-0149-00	1	CASE, STORAGE 24"-36" MDSF (NOT SHOWN)
9	69-0232-00	1	BAR, TRIP POSITIONING 28"-60"
10	69-0236-00	1	NAME PLATE
11	69-4000-28	1	28" ROTATING RING ASSEMBLY
12	69-4001-28	1	28" STATIONARY FRAME ASSEMBLY
13	69-4501-00	4	LEG SCREW ASSEMBLY, SHORT
14	69-4503-02	4	SCREW CLAMP ASSEMBLY 28" THRU 48", 2.00" STROKE
15	69-4800-00	4	EXTENSION LEG ASSEMBLY
16	69-4806-00	1	LASER ALIGNMENT TOOL
17	69-5501-00	1	KIT, MDSF 28"-48" FASTENERS (NOT SHOWN)
18	69-5600-00	1	KIT, HAND TOOLS MDSF (NOT SHOWN)
19	69-7002-01	1	HOLDER KIT, 37.5 DEG. INSIDE BEVEL
20	69-7002-02	1	INSERT, INSIDE BEVEL
21	69-LIT-01	1	TOOLING CHART, MDSF (NOT SHOWN)
22	69-LIT-02	1	TOOLING CONFIGURATION CHART, MDSF (NOT SHOWN)
23	69-MAN-01	1	MANUAL, MDSF (NOT SHOWN)
24	69-MAN-02	1	MANUAL, MDSF MAINTENANCE (NOT SHOWN)
25	90-049-06	4	SCREW, #2-3/16 U-DRIVE
26	90-400-04	1	WACHS CIRCLE LOGO 12" (NOT SHOWN)
27	90-404-00	1	LABEL, GENERAL PRODUCTS (NOT SHOWN)
28	90-1010-16	1	SHCS, M8 X 1.25MM X 16MM
29	90-1028-00	4	EYE BOLT, M14 X 2

Rev C

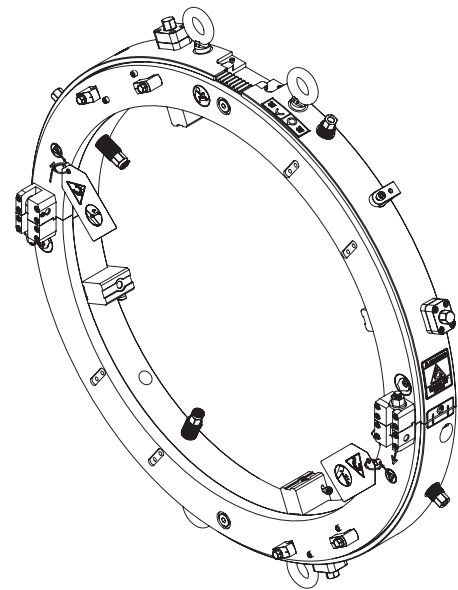

NOTE:
1. WIPER REQUIRE WAY OIL (PART NO.: 60-1184-00) SOLD SEPARATELY.

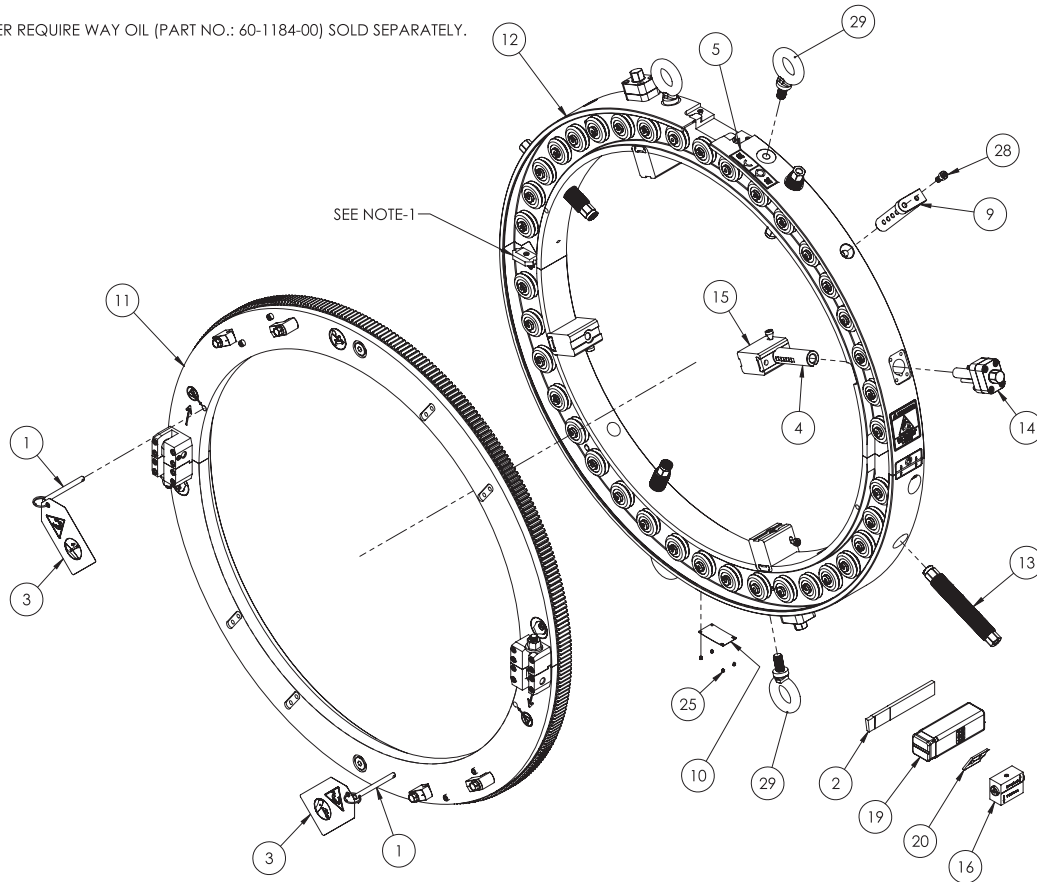

MDSF 32 po, 69-0000-32

ITEM	PART NUMBER	QTY	DESCRIPTION
1	60-129-00	2	PIN, FRAME LOCKING
2	60-711-00	1	PARTING TOOL, 1/4"
3	60-1274-00	2	TAG, LCSF
4	69-0049-00	4	LEG, 2.00"
5	69-0134-32	1	LABEL, WEIGHT-MDSF 32"
6	69-0136-00	1	LABEL, CASE (NOT SHOWN)
7	69-0148-00	1	INSERT, FOAM 24"-36" MDSF (NOT SHOWN)
8	69-0149-00	1	CASE, STORAGE 24"-36" MDSF (NOT SHOWN)
9	69-0232-00	1	BAR, TRIP POSITIONING 28"-60"
10	69-0236-00	1	NAME PLATE
11	69-4000-32	1	32" ROTATING RING ASSEMBLY
12	69-4001-32	1	32" STATIONARY FRAME ASSEMBLY
13	69-4501-00	4	LEG SCREW ASSEMBLY, SHORT
14	69-4503-02	4	SCREW CLAMP ASSEMBLY 28" THRU 48", 2.00" STROKE
15	69-4800-00	4	EXTENSION LEG ASSEMBLY
16	69-4806-00	1	LASER ALIGNMENT TOOL
17	69-5501-00	1	KIT, MDSF 28"-48" FASTENERS (NOT SHOWN)
18	69-5600-00	1	KIT, HAND TOOLS MDSF (NOT SHOWN)
19	69-7002-01	1	HOLDER KIT, 37.5 DEG. INSIDE BEVEL
20	69-7002-02	1	INSERT, INSIDE BEVEL
21	69-LIT-01	1	TOOLING CHART, MDSF (NOT SHOWN)
22	69-LIT-02	1	TOOLING CONFIGURATION CHART, MDSF (NOT SHOWN)
23	69-MAN-01	1	MANUAL, MDSF (NOT SHOWN)
24	69-MAN-02	1	MANUAL, MDSF MAINTENANCE (NOT SHOWN)
25	90-049-06	4	SCREW, #2-3/16 U-DRIVE
26	90-400-04	1	WACHS CIRCLE LOGO 12" (NOT SHOWN)
27	90-404-00	1	LABEL, GENERAL PRODUCTS (NOT SHOWN)
28	90-1010-16	1	SHCS, M8 X 1.25MM X 16MM
29	90-1028-00	4	EYE BOLT, M14 X 2

Rev C

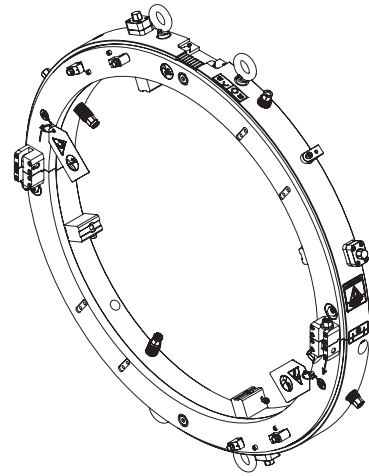

NOTE:

1. WIPER REQUIRE WAY OIL (PART NO.: 60-1184-00) SOLD SEPARATELY.

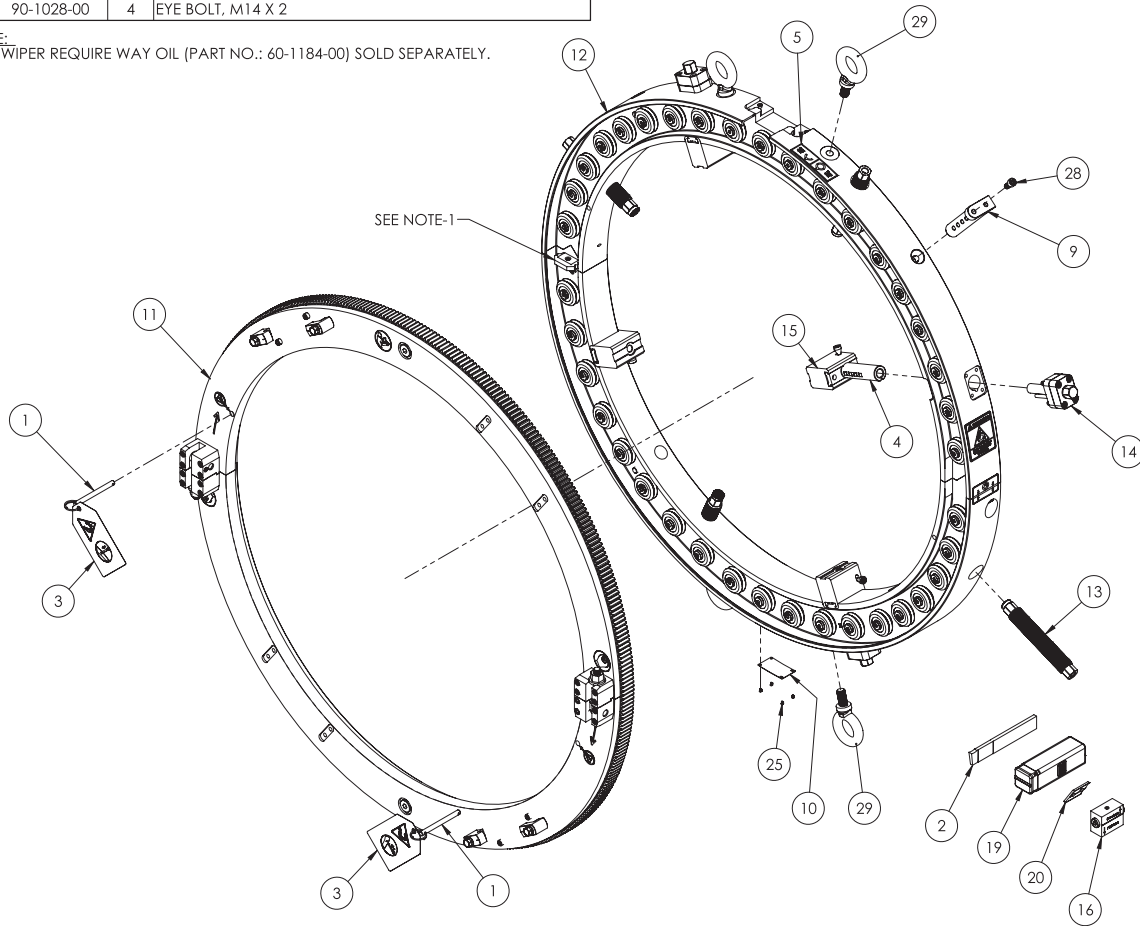

MDSF 36 po, 69-0000-36

ITEM	PART NUMBER	QTY	DESCRIPTION
1	60-129-00	2	PIN, FRAME LOCKING
2	60-711-00	1	PARTING TOOL, 1/4"
3	60-1274-00	2	TAG, LCSF
4	69-0049-00	4	LEG, 2.00"
5	69-0134-36	1	LABEL, WEIGHT-MDSF 36"
6	69-0136-00	1	LABEL, CASE (NOT SHOWN)
7	69-0148-00	1	INSERT, FOAM 24"-36" MDSF (NOT SHOWN)
8	69-0149-00	1	CASE, STORAGE 24"-36" MDSF (NOT SHOWN)
9	69-0232-00	1	BAR, TRIP POSITIONING 28"-60"
10	69-0236-00	1	NAME PLATE
11	69-4000-36	1	36" ROTATING RING ASSEMBLY
12	69-4001-36	1	36" STATIONARY FRAME ASSEMBLY
13	69-4501-00	4	LEG SCREW ASSEMBLY, SHORT
14	69-4503-02	4	SCREW CLAMP ASSEMBLY 28" THRU 48", 2.00" STROKE
15	69-4800-00	4	EXTENSION LEG ASSEMBLY
16	69-4806-00	1	LASER ALIGNMENT TOOL
17	69-5501-00	1	KIT, MDSF 28"-48" FASTENERS (NOT SHOWN)
18	69-5600-00	1	KIT, HAND TOOLS MDSF (NOT SHOWN)
19	69-7002-01	1	HOLDER KIT, 37.5 DEG. INSIDE BEVEL
20	69-7002-02	1	INSERT, INSIDE BEVEL
21	69-LIT-01	1	TOOLING CHART, MDSF (NOT SHOWN)
22	69-LIT-02	1	TOOLING CONFIGURATION CHART, MDSF (NOT SHOWN)
23	69-MAN-01	1	MANUAL, MDSF (NOT SHOWN)
24	69-MAN-02	1	MANUAL, MDSF MAINTENANCE (NOT SHOWN)
25	90-049-06	4	SCREW, #2-3/16 U-DRIVE
26	90-400-04	1	WACHS CIRCLE LOGO 12" (NOT SHOWN)
27	90-404-00	1	LABEL, GENERAL PRODUCTS (NOT SHOWN)
28	90-1010-16	1	SHCS, M8 X 1.25MM X 16MM
29	90-1028-00	4	EYE BOLT, M14 X 2

REV C

NOTE:
1. WIPER REQUIRE WAY OIL (PART NO.: 60-1184-00) SOLD SEPARATELY.

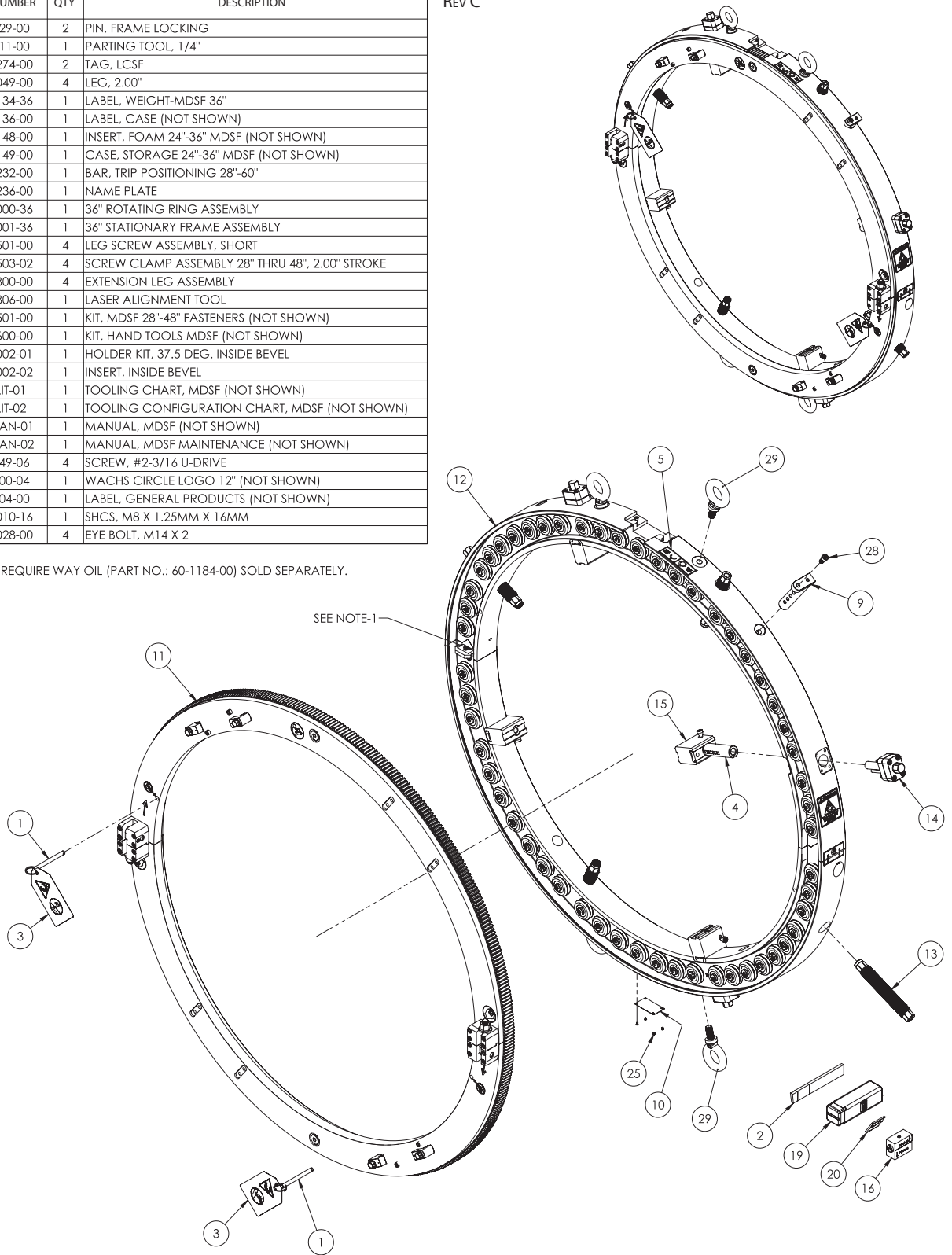

Ensemble du rotor 6 et 8 po, 69-4000-XX

ITEM	PART NUMBER	QTY	DESCRIPTION
1	60-029-00	2	LABEL, TIGHTEN NUT
2	60-1275-00	2	LABEL, PIN LOCATION
3	69-0127-00	4	PIN, 10MM X 16MM PULL-OUT DOWEL
4	69-1100-06	1	RING, FORGED ROTATING (6" MDSF)
	69-1100-08	1	RING, FORGED ROTATING (8" MDSF)
5	69-4502-00	2	SWING CLAMP ASSEMBLY
6	69-4502-01	2	SWING CLAMP ASSEMBLY, 6" & 8"
7	90-088-88	2	PLUG, SAE -8 (3/4-16 THREAD)
8	90-900-01	1	LABEL, READ MANUAL .75 DIA.

Rev A

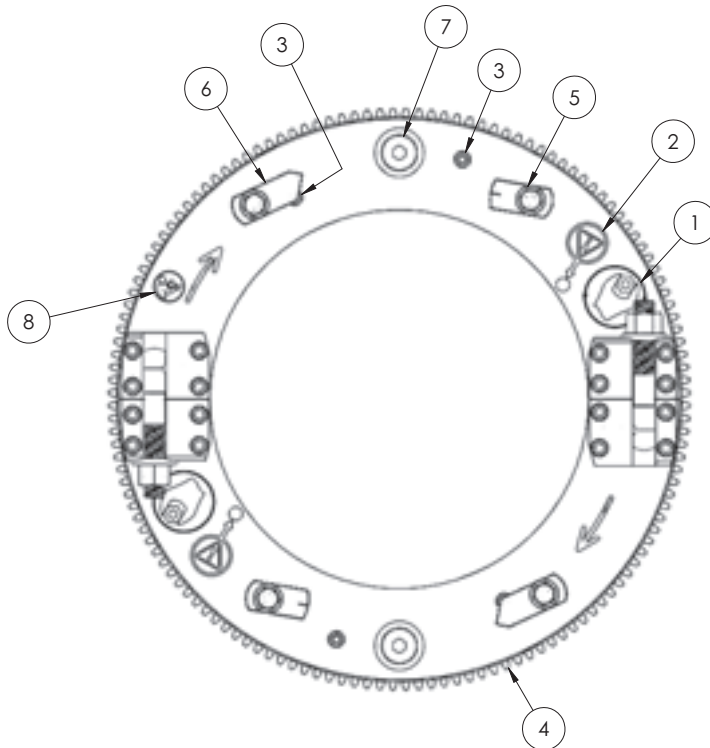
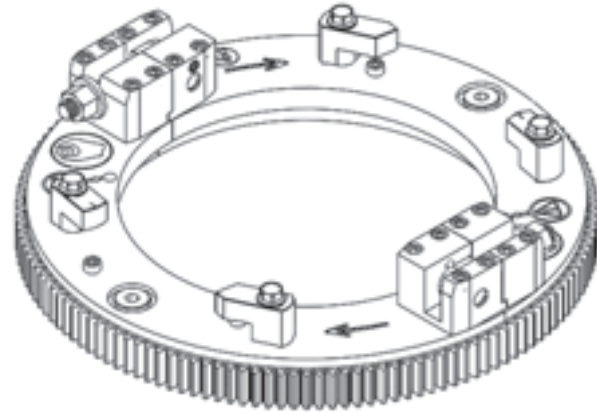

Ensemble du rotor 10 et 48 po, 69-4000-XX

REV A (10; 24-48)
REV B (12-24)

ITEM	PART NUMBER	QTY	DESCRIPTION
1	60-029-00	2	LABEL, TIGHTEN NUT
2	60-1275-00	2	LABEL, PIN LOCATION
3	69-0127-00	4	PIN, 10MM X 16MM PULL-OUT DOWEL
4	69-1100-XX	1	RING, FORGED ROTATING, SEE TABLE
5	69-4502-00	4	SWING CLAMP ASSEMBLY
6	90-088-88	2	PLUG, SAE -8 (3/4-16 THREAD)
7	90-900-01	1	LABEL, READ MANUAL .75 DIA. (10"-18")
	90-900-00	1	LABEL, READ MANUAL 1.5 DIA. (20"-48")

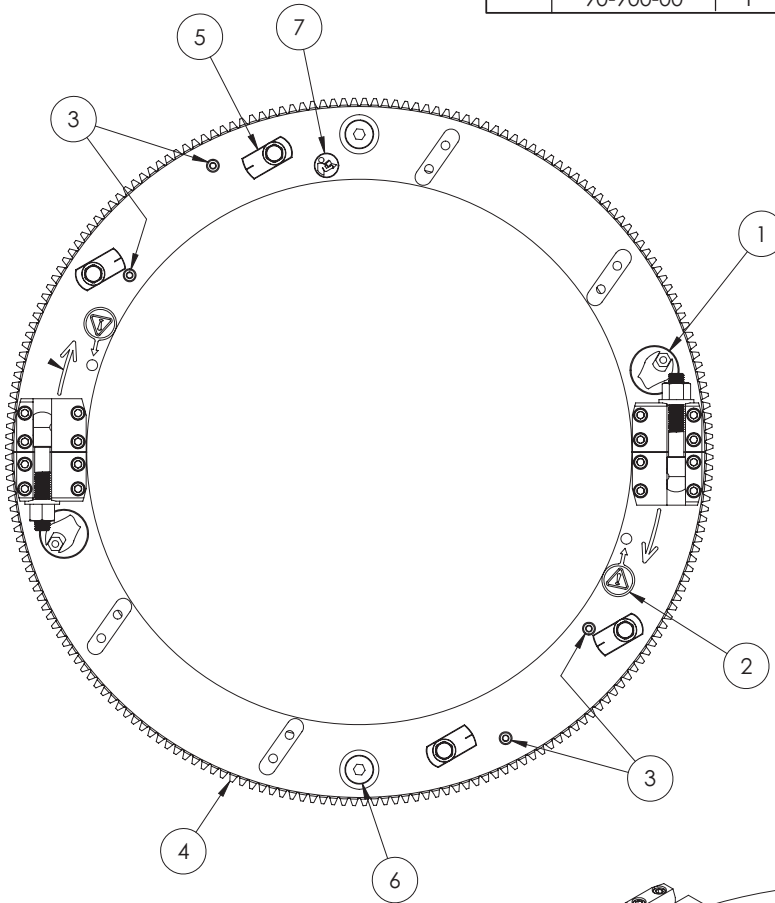

ITEM	MDSF MODEL	ROTATING RING
4	69-0000-10	69-1100-10
	69-0000-12	69-1100-12
	69-0000-14	69-1100-14
	69-0000-16	69-1100-16
	69-0000-18	69-1100-18
	69-0000-20	69-1100-20
	69-0000-24	69-1100-24
	69-0000-28	69-1100-28
	69-0000-32	69-1100-32
	69-0000-36	69-1100-36
69-0000-42	69-1100-42	
69-0000-48	69-1100-48	

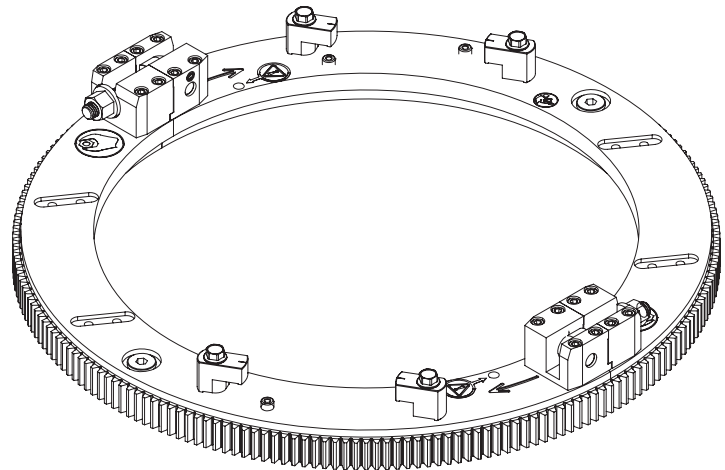

Ensemble du rotor 54 et 60 po, 69-4000-XX

ITEM	PART NUMBER	QTY	DESCRIPTION
1	60-029-00	2	LABEL, TIGHTEN NUT
2	60-1275-00	2	LABEL, PIN LOCATION
3	69-0127-00	4	PIN, 10MM X 16MM PULL-OUT DOWEL
4	69-1100-54	1	RING, FORGED ROTATING (54" MDSF)
	69-1100-60	1	RING, FORGED ROTATING (60" MDSF)
5	69-3066-00	4	TOE CLAMP ASSEMBLY, OD TRACKING 54"-60"
6	69-4502-00	4	SWING CLAMP ASSEMBLY
7	90-088-88	2	PLUG, SAE -8 (3/4-16 THREAD)
8	90-900-00	1	LABEL, READ MANUAL 1.50 DIA.

REV A

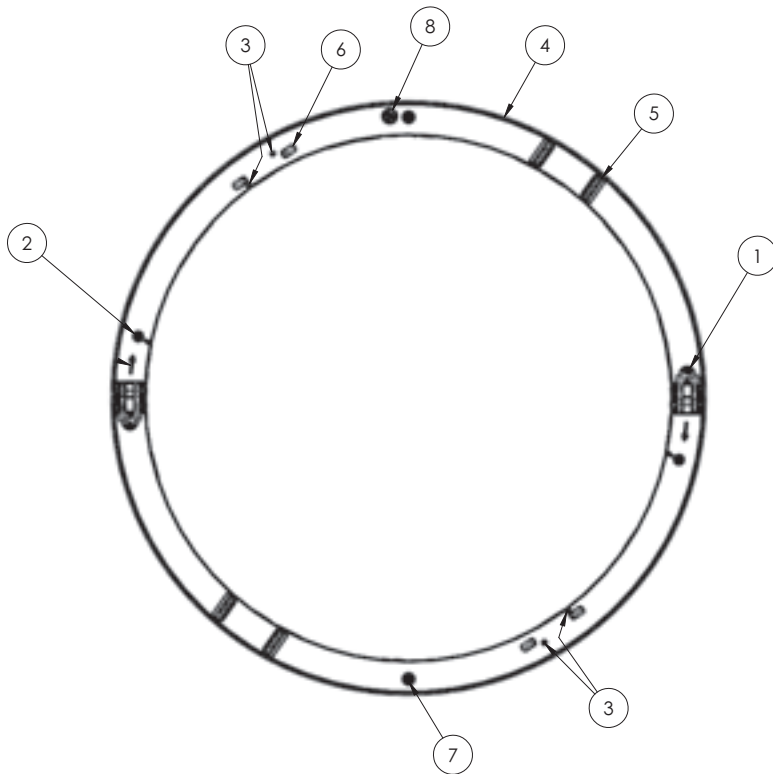
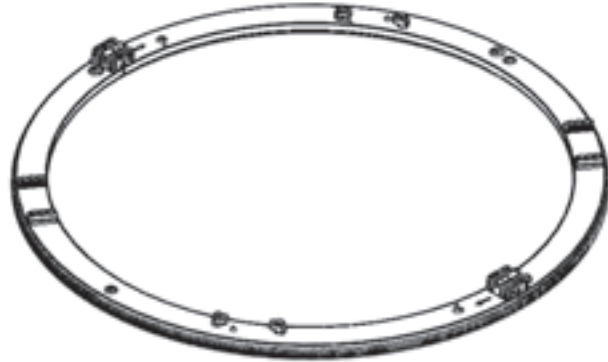

Ensemble du châssis fixe 6 po, 69-4001-06

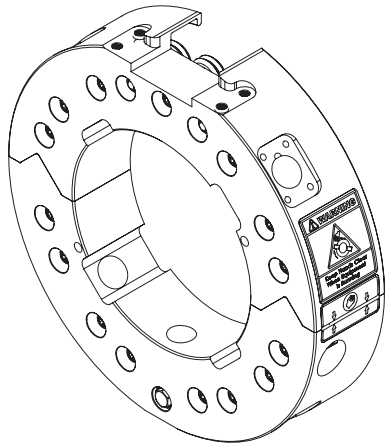

ITEM	PART NUMBER	QTY	DESCRIPTION
1	60-028-00	2	LABEL, NO GAPS
2	60-363-00	1	LABEL, MOVING PARTS
3	69-0073-00	1	SCREW, CAPTIVATED
4	69-0094-00	1	NUT, TRIP POSITIONING BAR
5	69-1200-06	1	RING, 6" STATIONARY FRAME
6	69-3021-00	1	WIPER ASSEMBLY, 6" THRU 24"
7	69-3051-00	2	STRAIGHT BEARING ASSEMBLY, OUTSIDE
8	69-3052-00	6	ECCENTRIC BEARING ASSEMBLY, OUTSIDE
9	69-3053-00	9	ECCENTRIC BEARING ASSEMBLY, INSIDE
10	69-8026-00	1	RING, RETAINING-SPIRAL
11	90-1016-00	17	NUT, M8 NYLOCK
12	90-1017-00	17	WASHER, M8 SECURING

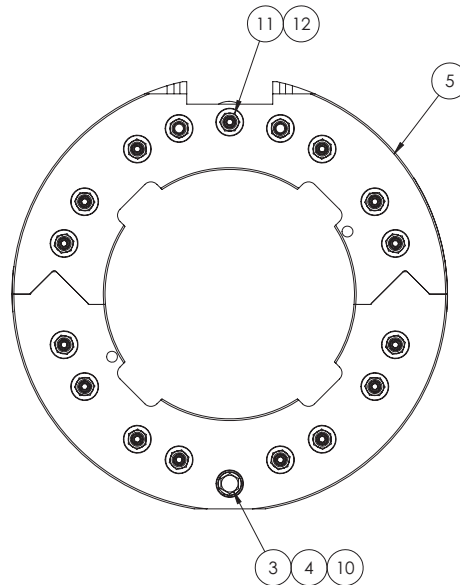
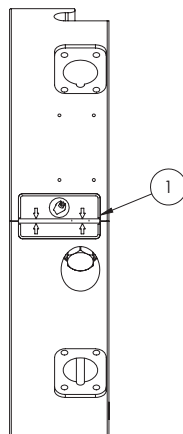
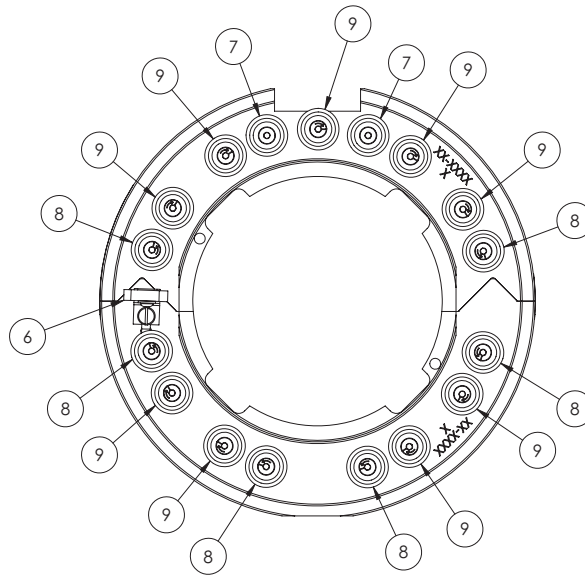
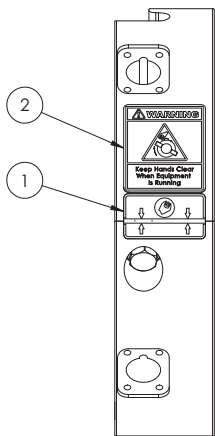

Ensemble du châssis fixe 8 po, 69-4001-08

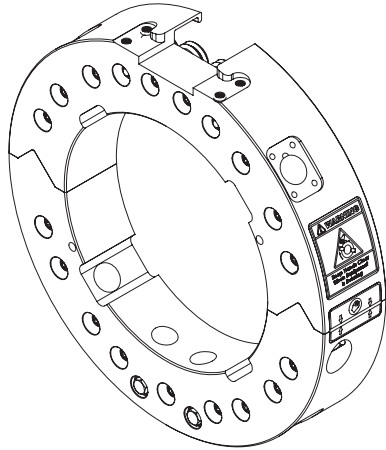

ITEM	PART NUMBER	QTY	DESCRIPTION
1	60-028-00	2	LABEL, NO GAPS
2	60-363-00	1	LABEL, MOVING PARTS
3	69-0073-00	2	SCREW, CAPTIVATED
4	69-0094-00	2	NUT, TRIP POSITIONING BAR
5	69-1200-08	1	RING, 8" STATIONARY FRAME
6	69-3021-00	1	WIPER ASSEMBLY, 6" THRU 24"
7	69-3051-00	2	STRAIGHT BEARING ASSEMBLY, OUTSIDE
8	69-3052-00	6	ECCENTRIC BEARING ASSEMBLY, OUTSIDE
9	69-3053-00	11	ECCENTRIC BEARING ASSEMBLY, INSIDE
10	69-8026-00	2	RING, RETAINING SPIRAL
11	90-1016-00	19	NUT, M8 NYLOCK
12	90-1017-00	19	WASHER, M8 SECURING

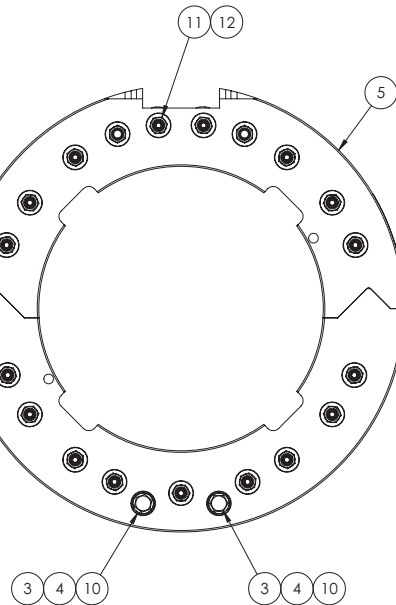
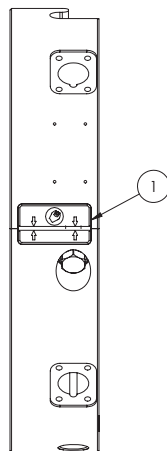
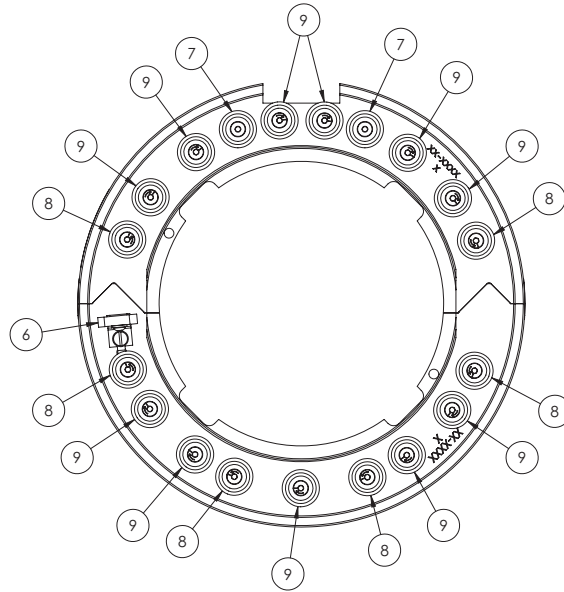
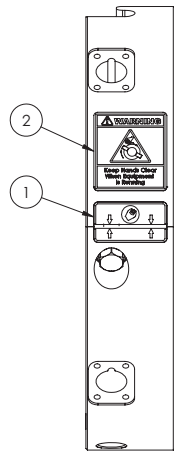

Ensemble du châssis fixe 10 po, 69-4001-10

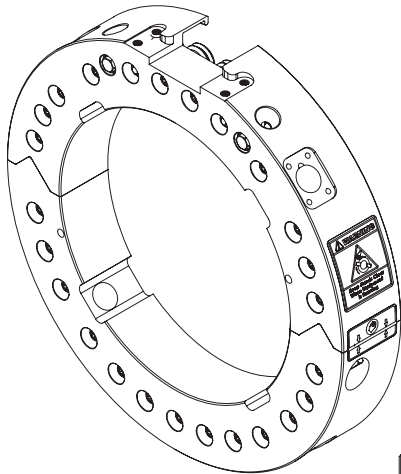

REV A	ITEM	PART NUMBER	QTY	DESCRIPTION
	1	60-028-00	2	LABEL, NO GAPS
	2	60-363-00	2	LABEL, MOVING PARTS
	3	69-0073-00	2	SCREW, CAPTIVATED
	4	69-0094-00	2	NUT, TRIP POSITIONING BAR
	5	69-1200-10	1	RING, 10" STATIONARY FRAME
	6	69-3021-00	1	WIPER ASSEMBLY, 6" THRU 24"
	7	69-3051-00	2	STRAIGHT BEARING ASSEMBLY, OUTSIDE
	8	69-3052-00	12	ECCENTRIC BEARING ASSEMBLY, OUTSIDE
	9	69-3053-00	11	ECCENTRIC BEARING ASSEMBLY, INSIDE
	10	69-8025-00	2	SPRING PLUNGER
	11	69-8026-00	2	RING, RETAINING-SPIRAL
	12	90-1016-00	25	NUT, M8 NYLOCK
	13	90-1017-00	25	WASHER, M8 SECURING

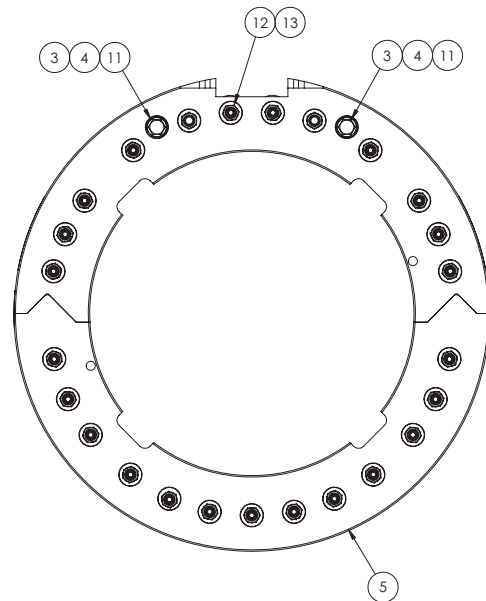
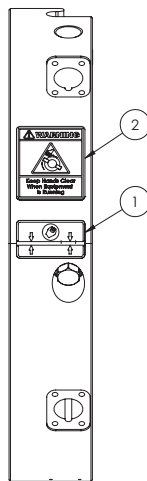
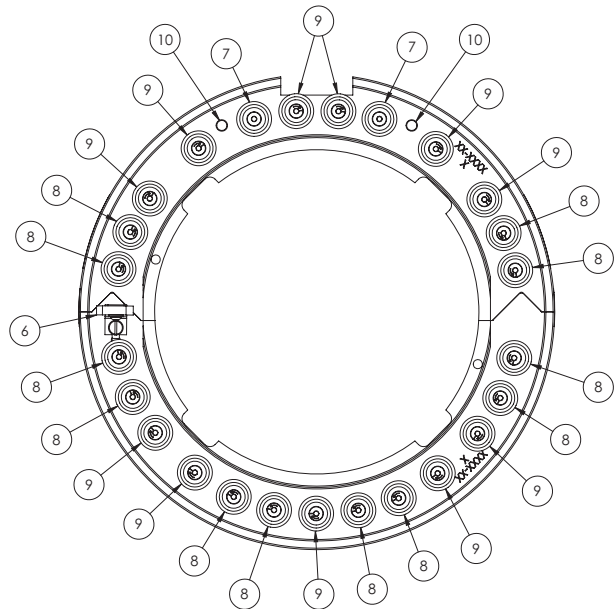
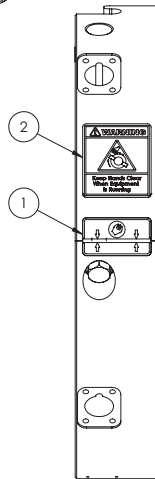

Ensemble du châssis fixe 12 po, 69-4001-12

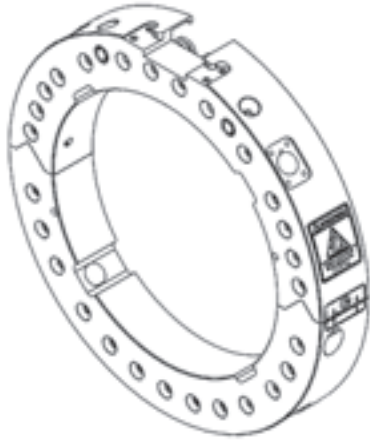

REV B

ITEM	PART NUMBER	QTY	DESCRIPTION
1	60-028-00	2	LABEL, NO GAPS
2	60-363-00	2	LABEL, MOVING PARTS
3	69-0073-00	2	SCREW, CAPTIVATED
4	69-0094-00	2	NUT, TRIP POSITIONING BAR
5	69-1200-12	1	RING, 12" STATIONARY FRAME
6	69-3021-00	1	WIPER ASSEMBLY, 6" THRU 24"
7	69-3051-00	2	STRAIGHT BEARING ASSEMBLY, OUTSIDE
8	69-3052-00	12	ECCENTRIC BEARING ASSEMBLY, OUTSIDE
9	69-3053-00	13	ECCENTRIC BEARING ASSEMBLY, INSIDE
10	69-8025-00	2	SPRING PLUNGER
11	69-8026-00	2	RING, RETAINING-SPIRAL
12	90-1016-00	27	NUT, M8 NYLOCK
13	90-1017-00	27	WASHER, M8 SECURING

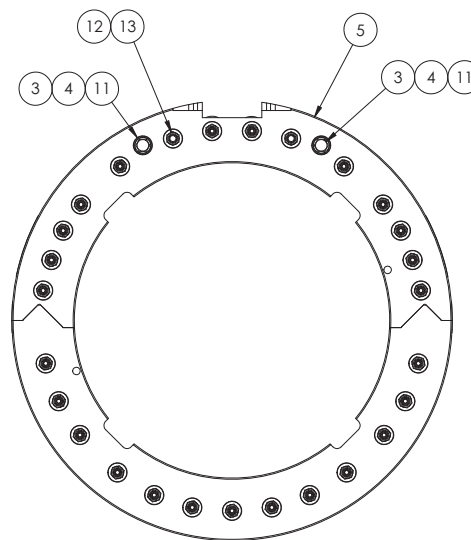
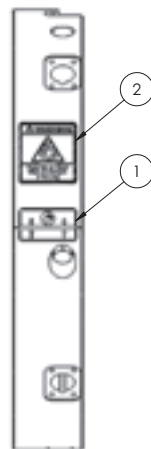
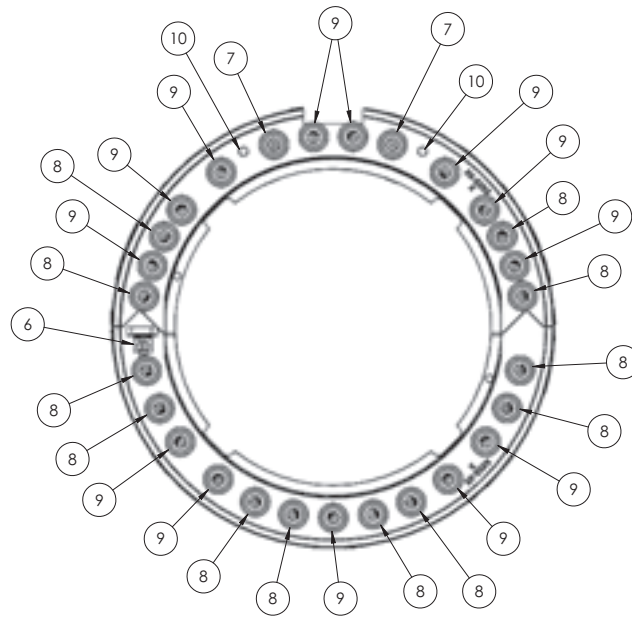
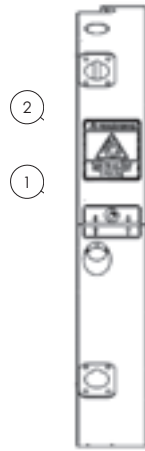

Ensemble du châssis fixe 14 po, 69-4001-14

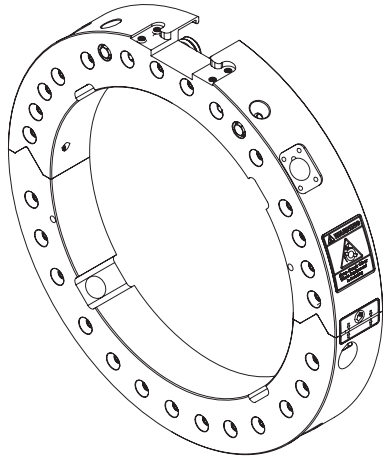

Rev C

ITEM	PART NUMBER	QTY	DESCRIPTION
1	60-028-00	2	LABEL, NO GAPS
2	60-363-00	2	LABEL, MOVING PARTS
3	69-0073-00	2	SCREW, CAPTIVATED
4	69-0094-00	2	NUT, TRIP POSITIONING BAR
5	69-1200-14	1	RING, 14" STATIONARY FRAME
6	69-3021-00	1	WIPER ASSEMBLY, 6" THRU 24"
7	69-3051-00	2	STRAIGHT BEARING ASSEMBLY, OUTSIDE
8	69-3052-00	12	ECCENTRIC BEARING ASSEMBLY, OUTSIDE
9	69-3053-00	13	ECCENTRIC BEARING ASSEMBLY, INSIDE
10	69-8025-00	2	SPRING PLUNGER
11	69-8026-00	2	RING, RETAINING-SPIRAL
12	90-1016-00	27	NUT, M8 NYLOCK
13	90-1017-00	27	WASHER, M8 SECURING

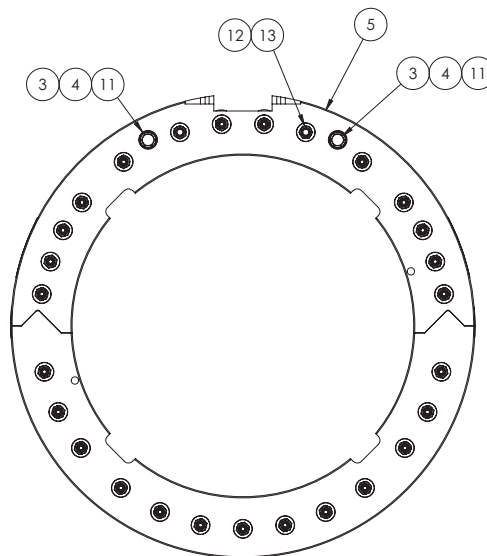
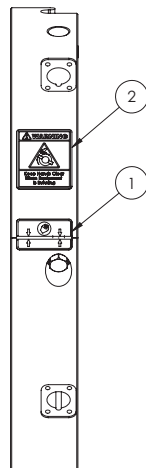
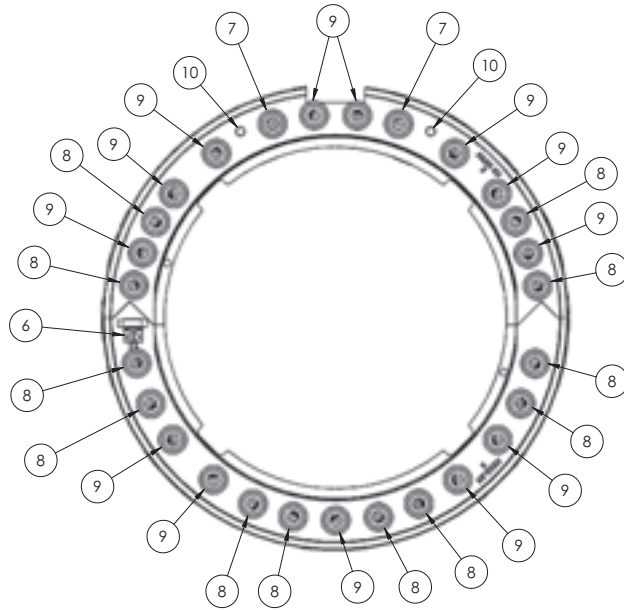
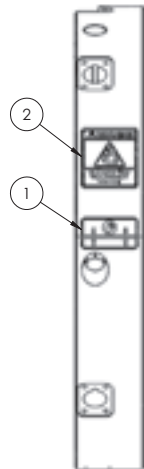

Ensemble du châssis fixe 16 po, 69-4001-16

ITEM	PART NUMBER	QTY	DESCRIPTION
1	60-028-00	2	LABEL, NO GAPS
2	60-363-00	2	LABEL, MOVING PARTS
3	69-0073-00	4	SCREW, CAPTIVATED
4	69-0094-00	4	NUT, TRIP POSITIONING BAR
5	69-1200-16	1	RING, 16" STATIONARY FRAME
6	69-3021-00	1	WIPER ASSEMBLY, 6" THRU 24"
7	69-3051-00	2	STRAIGHT BEARING ASSEMBLY, OUTSIDE
8	69-3052-00	14	ECCENTRIC BEARING ASSEMBLY, OUTSIDE
9	69-3053-00	16	ECCENTRIC BEARING ASSEMBLY, INSIDE
10	69-8025-00	4	SPRING PLUNGER
11	69-8026-00	4	RING, RETAINING-SPIRAL
12	90-1016-00	32	NUT, M8 NYLOCK
13	90-1017-00	32	WASHER, M8 SECURING

REV B

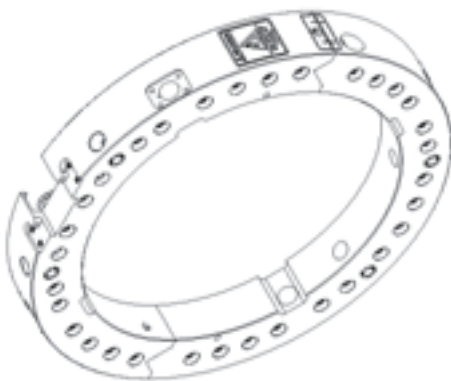
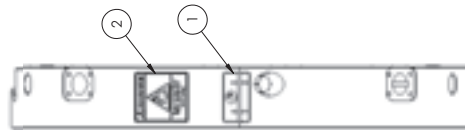
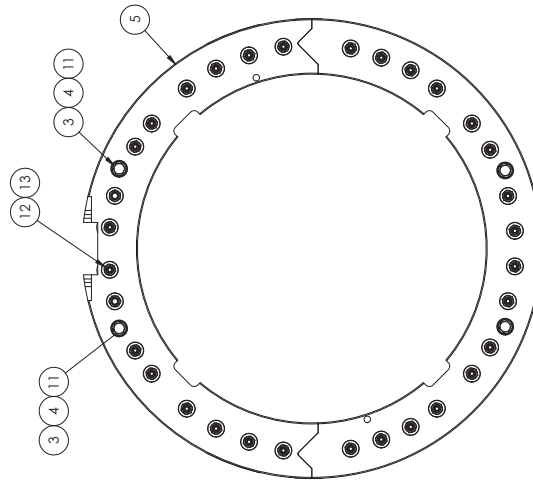
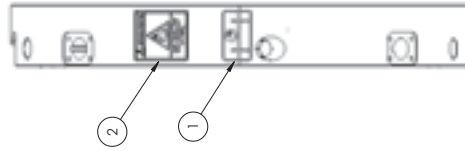
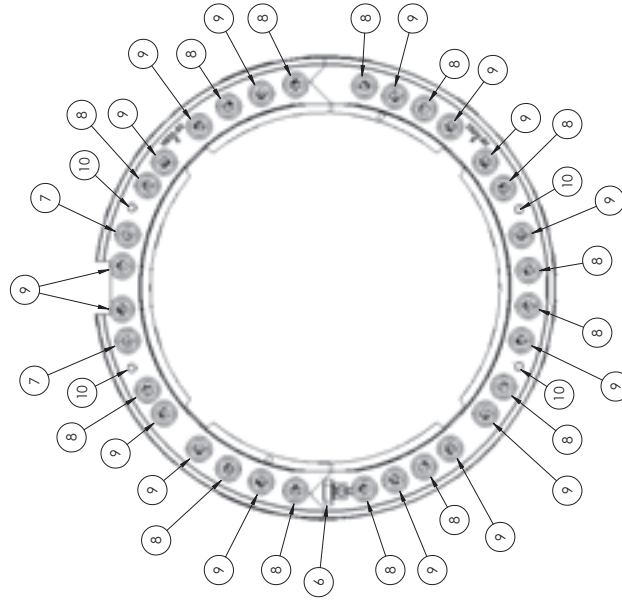

Ensemble du châssis fixe 18 po, 69-4001-18

ITEM	PART NUMBER	QTY	DESCRIPTION
1	60-028-00	2	LABEL, NO GAPS
2	60-363-00	2	LABEL, MOVING PARTS
3	69-0073-00	4	SCREW, CAPTIVATED
4	69-0094-00	4	NUT, TRIP POSITIONING BAR
5	69-1200-18	1	RING, 18" STATIONARY FRAME
6	69-3021-00	1	WIPER ASSEMBLY, 6" THRU 24"
7	69-3051-00	2	STRAIGHT BEARING ASSEMBLY, OUTSIDE
8	69-3052-00	14	ECCENTRIC BEARING ASSEMBLY, OUTSIDE
9	69-3053-00	16	ECCENTRIC BEARING ASSEMBLY, INSIDE
10	69-8025-00	4	SPRING PLUNGER
11	69-8026-00	4	RING, RETAINING-SPIRAL
12	90-1016-00	32	NUT, M8 NYLOCK
13	90-1017-00	32	WASHER, M8 SECURING

REV B

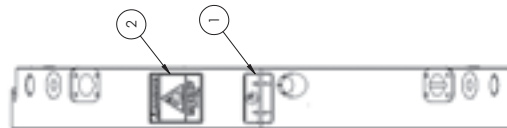
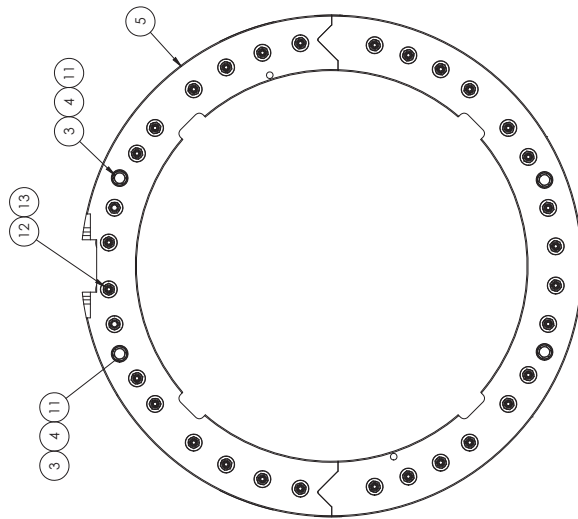
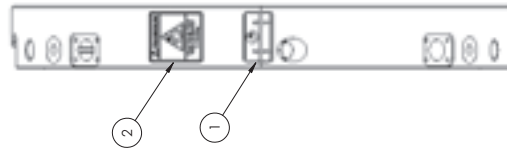
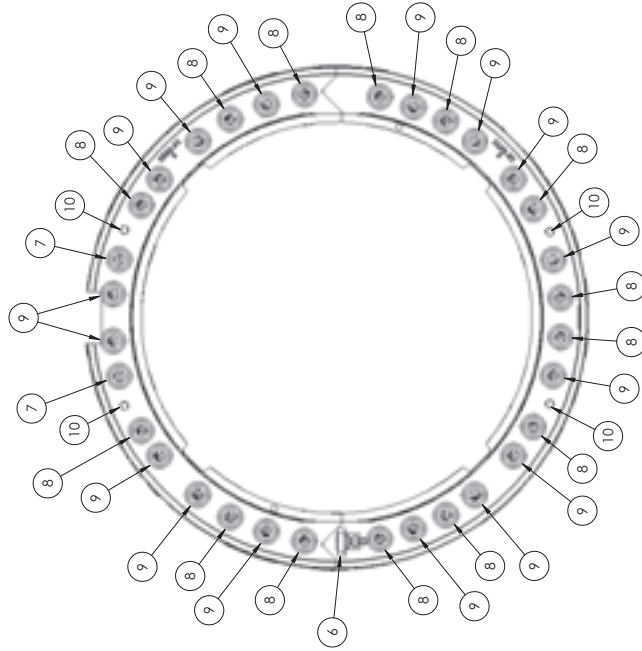
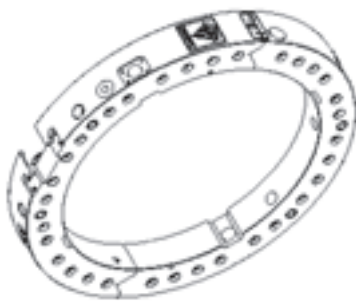

Ensemble du châssis fixe 20 po, 69-4001-20

ITEM	PART NUMBER	QTY	DESCRIPTION
1	60-028-00	2	LABEL, NO GAPS
2	60-363-00	2	LABEL, MOVING PARTS
3	69-0073-00	4	SCREW, CAPTIVATED
4	69-0094-00	4	NUT, TRIP POSITIONING BAR
5	69-1200-20	1	RING, 20" STATIONARY FRAME
6	69-3021-00	1	WIPER ASSEMBLY, 6" THRU 24"
7	69-3051-00	2	STRAIGHT BEARING ASSEMBLY, OUTSIDE
8	69-3052-00	14	ECCENTRIC BEARING ASSEMBLY, OUTSIDE
9	69-3053-00	20	ECCENTRIC BEARING ASSEMBLY, INSIDE
10	69-8025-00	4	SPRING PLUNGER
11	69-8026-00	4	RING, RETAINING-SPIRAL
12	90-1016-00	36	NUT, M8 NYLOCK
13	90-1017-00	36	WASHER, M8 SECURING

REV B

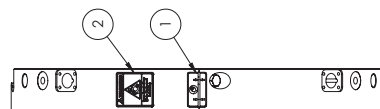
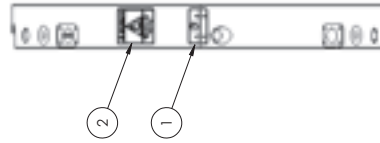
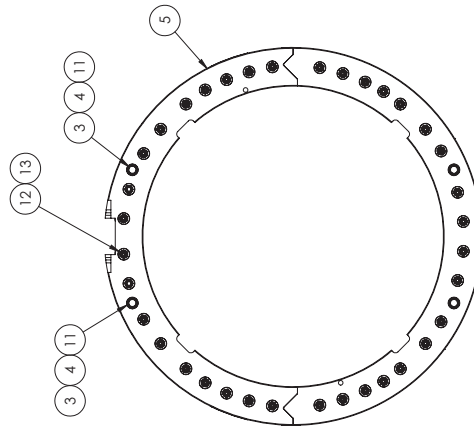
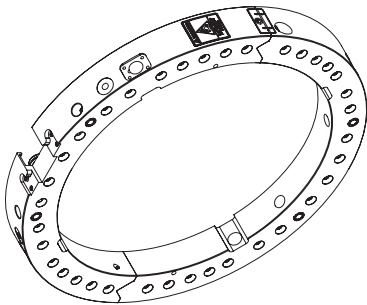
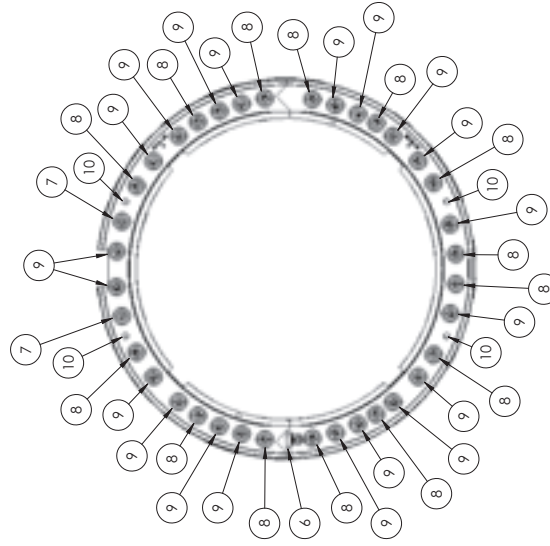

Ensemble du châssis fixe 24 po, 69-4001-24

ITEM	PART NUMBER	QTY	DESCRIPTION
1	60-028-00	2	LABEL, NO GAPS
2	60-363-00	2	LABEL, MOVING PARTS
3	69-0073-00	4	SCREW, CAPTIVATED
4	69-0094-00	4	NUT, TRIP POSITIONING BAR
5	69-1200-24	1	RING, 24" STATIONARY FRAME
6	69-3021-00	1	WIPER ASSEMBLY, 6" THRU 24"
7	69-3051-00	2	STRAIGHT BEARING ASSEMBLY, OUTSIDE
8	69-3052-00	14	ECCENTRIC BEARING ASSEMBLY, OUTSIDE
9	69-3053-00	27	ECCENTRIC BEARING ASSEMBLY, INSIDE
10	69-8025-00	4	SPRING FLINGER
11	69-8026-00	4	RING, RETAINING-SPIRAL
12	90-1016-00	43	NUT, M8 NYLOCK
13	90-1017-00	43	WASHER, M8 SECURING

REV B

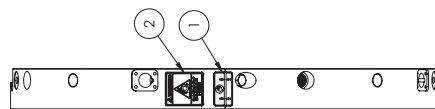
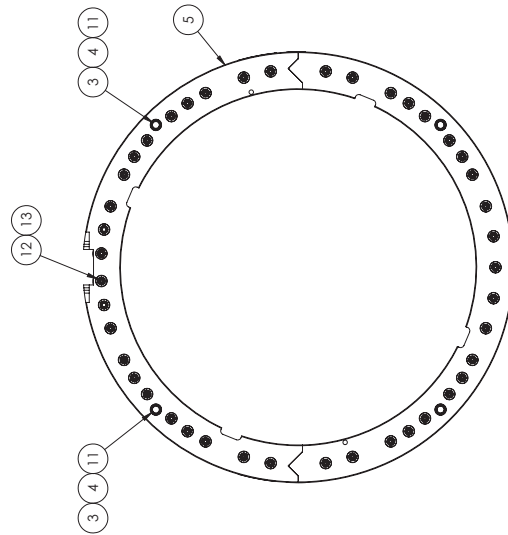
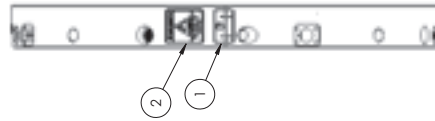
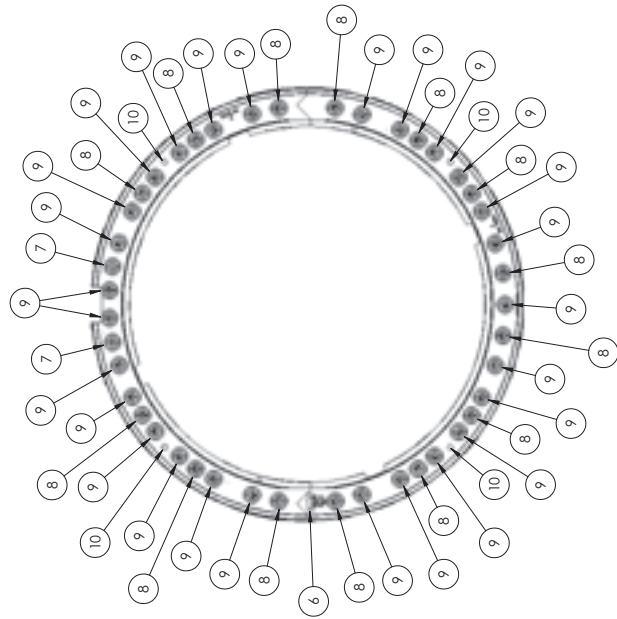
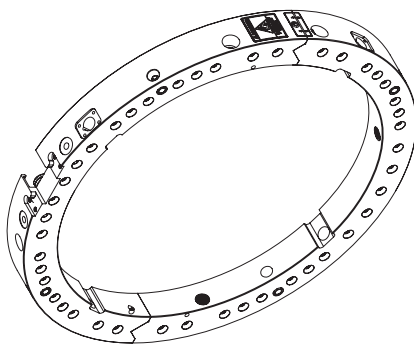

Ensemble du châssis fixe 28 po, 69-4001-28



Rev A

ITEM	PART NUMBER	QTY	DESCRIPTION
1	60-028-00	2	LABEL, NO GAPS
2	60-363-00	2	LABEL, MOVING PARTS
3	69-0073-00	4	SCREW, CAPTIVATED
4	69-0094-00	4	NUT, TRIP POSITIONING BAR
5	69-1200-28	1	RING, 28" STATIONARY FRAME
6	69-3048-00	22	ECCENTRIC BEARING ASSEMBLY, INSIDE
7	69-3049-00	2	STRAIGHT BEARING ASSEMBLY, OUTSIDE
8	69-3050-00	14	ECCENTRIC BEARING ASSEMBLY, OUTSIDE
9	69-3064-00	1	WIPER ASSEMBLY, 28" THRU 48"
10	69-8025-00	4	SPRING PLUNGER
11	69-8026-00	4	RING, RETAINING-SPIRAL
12	90-075-59	38	WASHER, 3/8 SECURING
13	90-1042-00	38	NUT, M10 NYLOCK

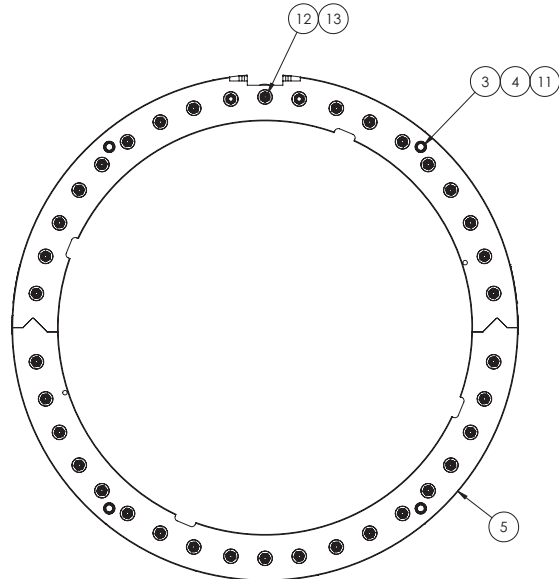
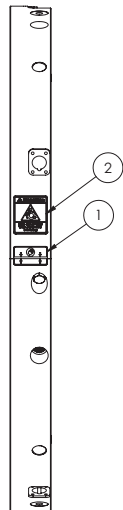
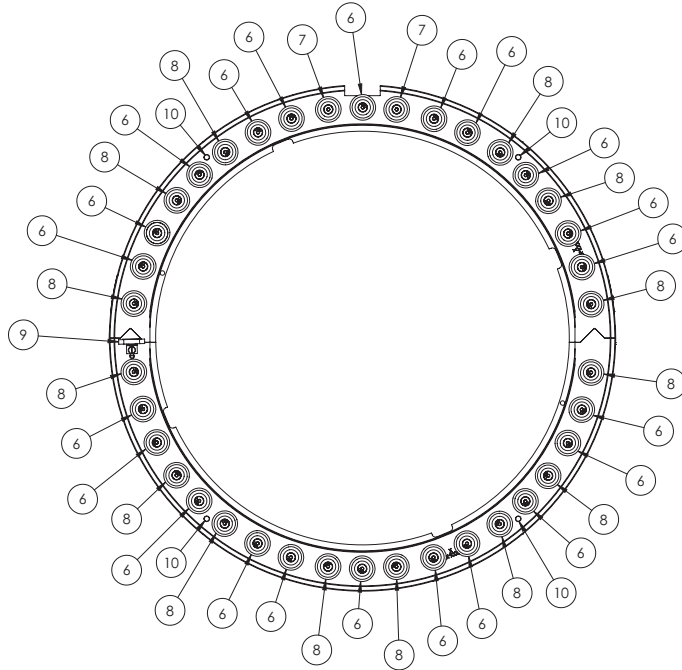
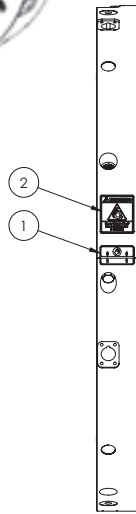

Ensemble du châssis fixe 32 po, 69-4001-32

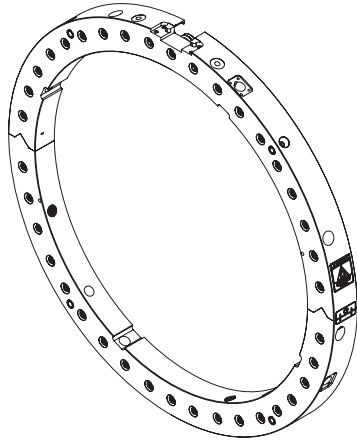

Rev A	ITEM	PART NUMBER	QTY	DESCRIPTION
	1	60-028-00	2	LABEL, NO GAPS
	2	60-363-00	2	LABEL, MOVING PARTS
	3	69-0073-00	4	SCREW, CAPTIVATED
	4	69-0094-00	4	NUT, TRIP POSITIONING BAR
	5	69-1200-32	1	RING, 28" STATIONARY FRAME
	6	69-3048-00	22	ECCENTRIC BEARING ASSEMBLY, INSIDE
	7	69-3049-00	2	STRAIGHT BEARING ASSEMBLY, OUTSIDE
	8	69-3050-00	14	ECCENTRIC BEARING ASSEMBLY, OUTSIDE
	9	69-3064-00	1	WIPER ASSEMBLY, 28" THRU 48"
	10	69-8025-00	4	SPRING PLUNGER
	11	69-8026-00	4	RING, RETAINING-SPIRAL
	12	90-075-59	38	WASHER, 3/8 SECURING
	13	90-1042-00	38	NUT, M10 NYLOCK

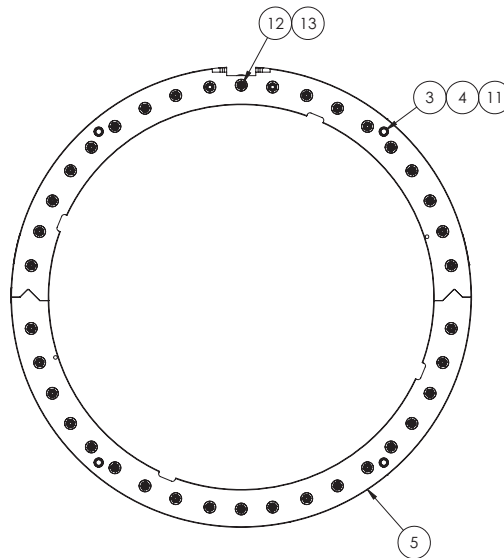
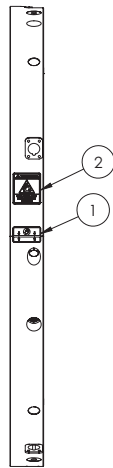
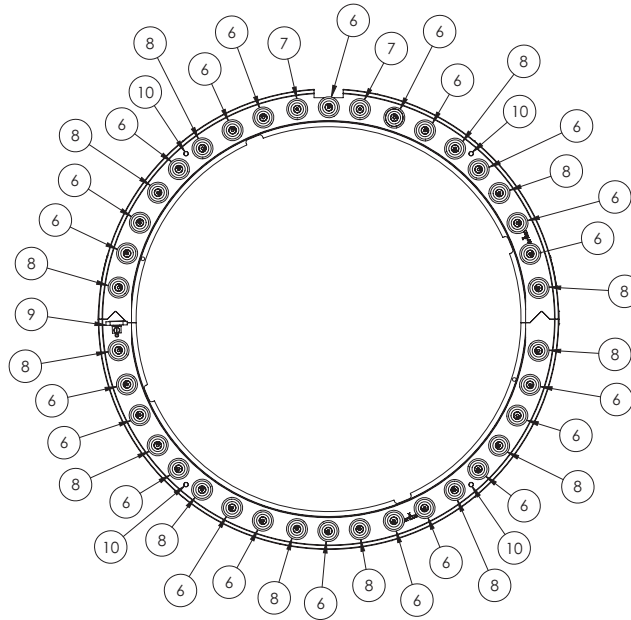
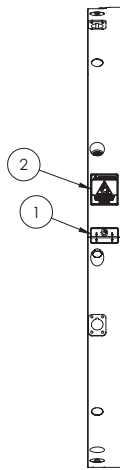

Ensemble du châssis fixe 36 po, 69-4001-36

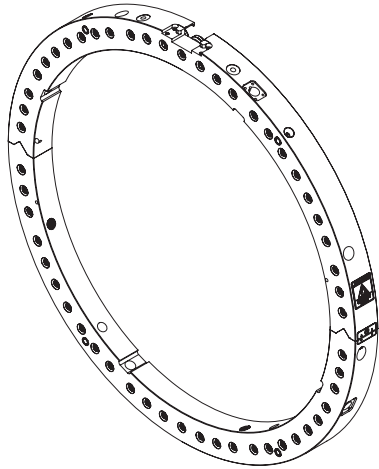

ITEM	PART NUMBER	QTY	DESCRIPTION
1	60-028-00	2	LABEL, NO GAPS
2	60-363-00	2	LABEL, MOVING PARTS
3	69-0073-00	4	SCREW, CAPTIVATED
4	69-0094-00	4	NUT, TRIP POSITIONING BAR
5	69-1200-36	1	RING, 36" STATIONARY FRAME
6	69-3048-00	26	ECCENTRIC BEARING ASSEMBLY, INSIDE
7	69-3049-00	2	STRAIGHT BEARING ASSEMBLY, OUTSIDE
8	69-3050-00	26	ECCENTRIC BEARING ASSEMBLY, OUTSIDE
9	69-3064-00	1	WIPER ASSEMBLY, 28" THRU 48"
10	69-8025-00	4	SPRING PLUNGER
11	69-8026-00	4	RING, RETAINING-SPIRAL
12	90-075-59	54	WASHER, 3/8 SECURING
13	90-1042-00	54	NUT, M10 NYLOCK

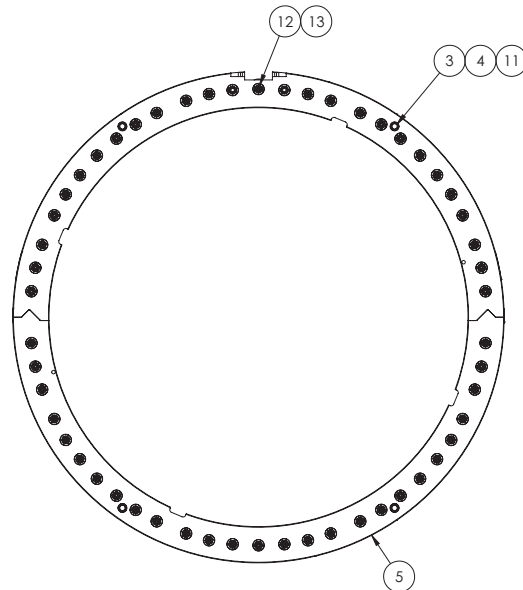
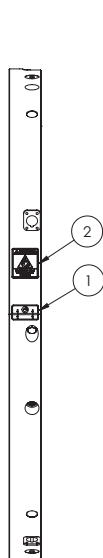
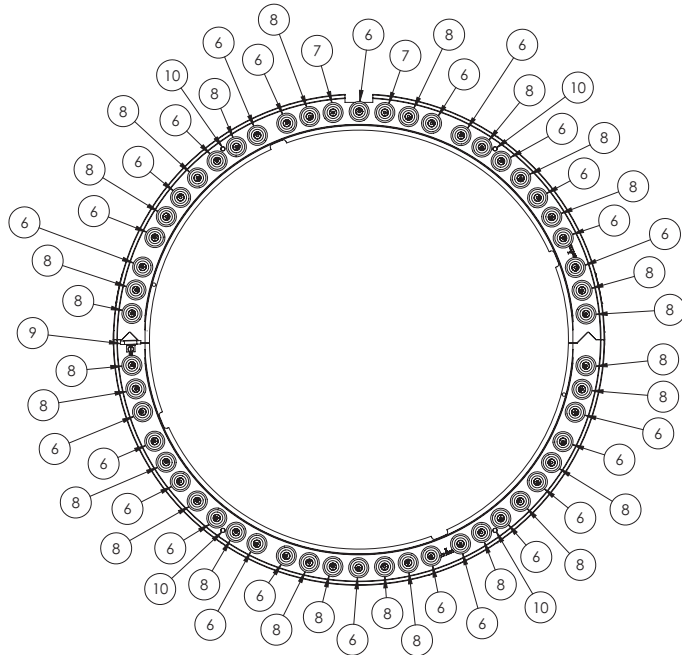
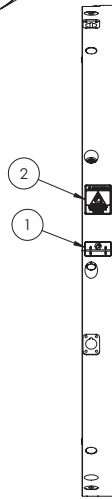

Ensemble du châssis fixe 42 po, 69-4001-42

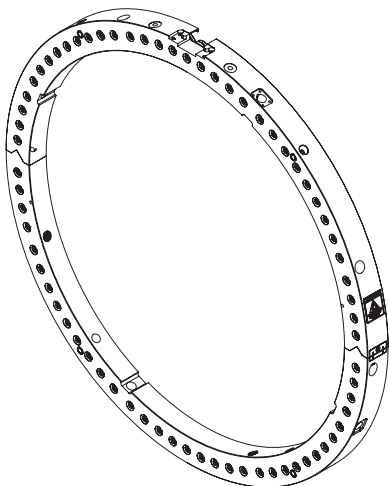

ITEM	PART NUMBER	QTY	DESCRIPTION
1	60-028-00	2	LABEL, NO GAPS
2	60-363-00	2	LABEL, MOVING PARTS
3	69-0073-00	4	SCREW, CAPTIVATED
4	69-0074-00	4	NUT, TRIP POSITIONING BAR
5	69-1200-42	1	RING, 42" STATIONARY FRAME
6	69-3048-00	38	ECCENTRIC BEARING ASSEMBLY, INSIDE
7	69-3049-00	2	STRAIGHT BEARING ASSEMBLY, OUTSIDE
8	69-3050-00	30	ECCENTRIC BEARING ASSEMBLY, OUTSIDE
9	69-3064-00	1	WIPER ASSEMBLY, 28" THRU 48"
10	69-8025-00	4	SPRING PLUNGER
11	69-8026-00	4	RING, RETAINING-SPIRAL
12	90-075-59	70	WASHER, 3/8 SECURING
13	90-1042-00	70	NUT, M10 NYLOCK

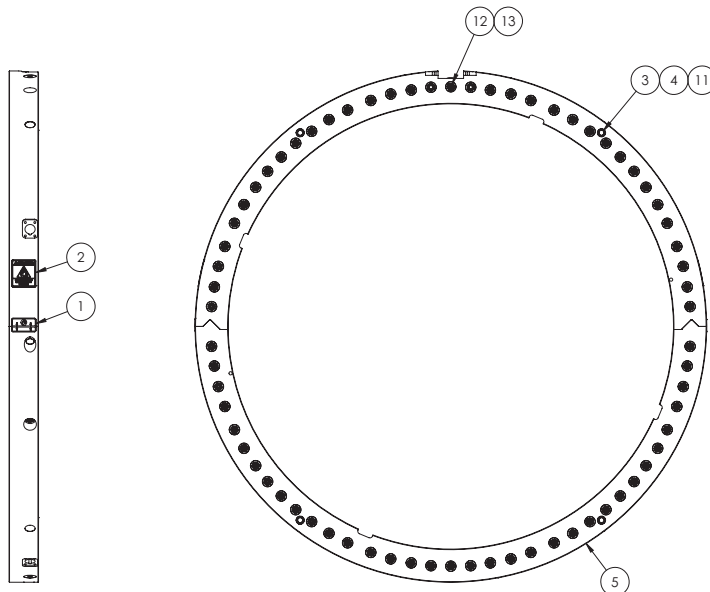
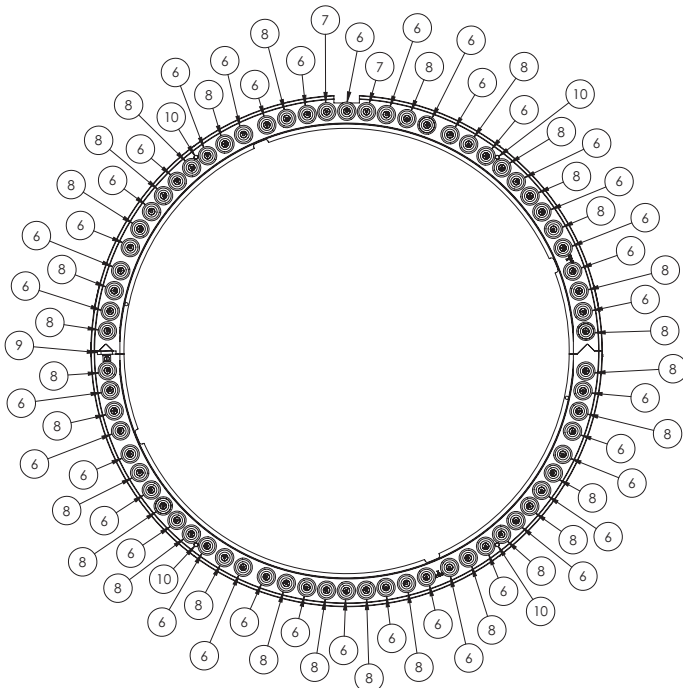
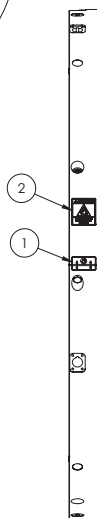

Ensemble du châssis fixe 48 po, 69-4001-48

REV A

ITEM	PART NUMBER	QTY	DESCRIPTION
1	60-028-00	2	LABEL, NO GAPS
2	60-363-00	2	LABEL, MOVING PARTS
3	69-0073-00	4	SCREW, CAPTIVATED
4	69-0094-00	4	NUT, TRIP POSITIONING BAR
5	69-1200-48	1	RING, 48" STATIONARY FRAME
6	69-3048-00	38	ECCENTRIC BEARING ASSEMBLY, INSIDE
7	69-3049-00	2	STRAIGHT BEARING ASSEMBLY, OUTSIDE
8	69-3050-00	30	ECCENTRIC BEARING ASSEMBLY, OUTSIDE
9	69-3064-00	1	WIPER ASSEMBLY, 28" THRU 48"
10	69-8025-00	4	SPRING PLUNGER
11	69-8026-00	4	RING, RETAINING-SPIRAL
12	90-075-59	70	WASHER, 3/8 SECURING
13	90-1042-00	70	NUT, M10 NYLOCK

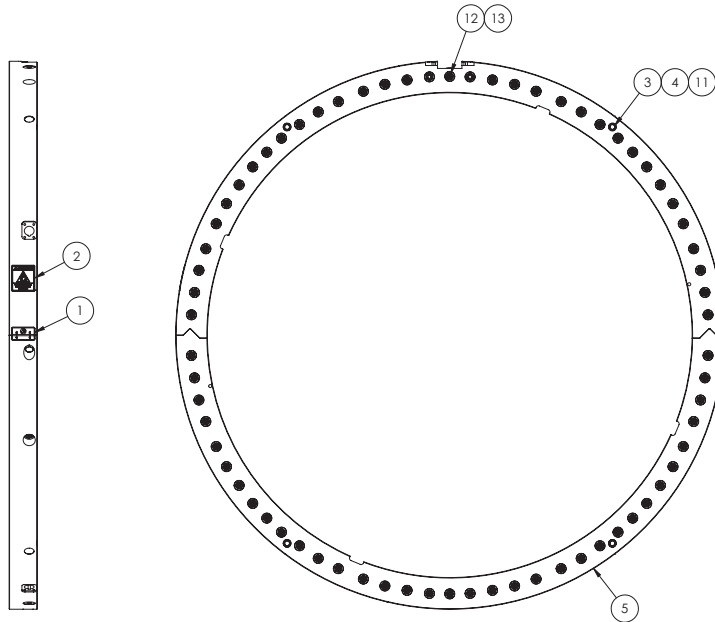
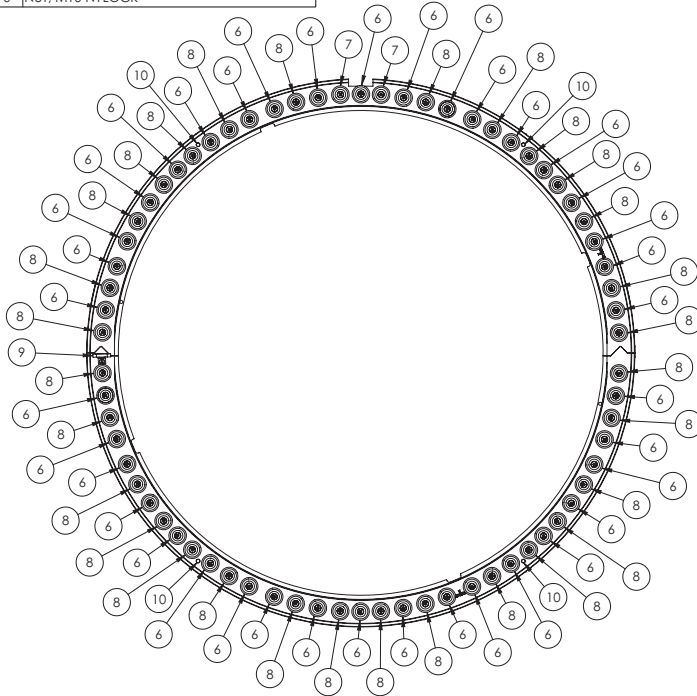
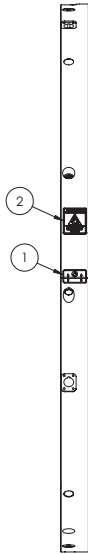
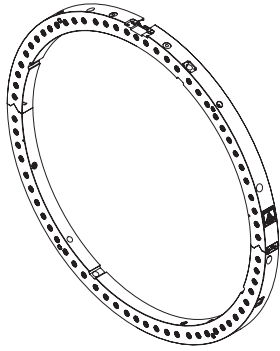

Ensemble du châssis fixe 54 po, 69-4001-54

REV A

ITEM	PART NUMBER	QTY	DESCRIPTION
1	60-028-00	2	LABEL, NO GAPS
2	60-363-00	2	LABEL, MOVING PARTS
3	69-0073-00	4	SCREW, CAPTIVATED
4	69-0094-00	4	NUT, TRIP POSITIONING BAR
5	69-1200-54	1	RING, 54" STATIONARY FRAME
6	69-3048-00	38	ECCENTRIC BEARING ASSEMBLY, INSIDE
7	69-3049-00	2	STRAIGHT BEARING ASSEMBLY, OUTSIDE
8	69-3050-00	30	ECCENTRIC BEARING ASSEMBLY, OUTSIDE
9	69-3065-00	1	WIPER ASSEMBLY, 54" THRU 60"
10	69-8025-00	4	SPRING PLUNGER
11	69-8026-00	4	RING, RETAINING-SPIRAL
12	90-075-59	70	WASHER, 3/8 SECURING
13	90-1042-00	70	NUT, M10 NYLOCK

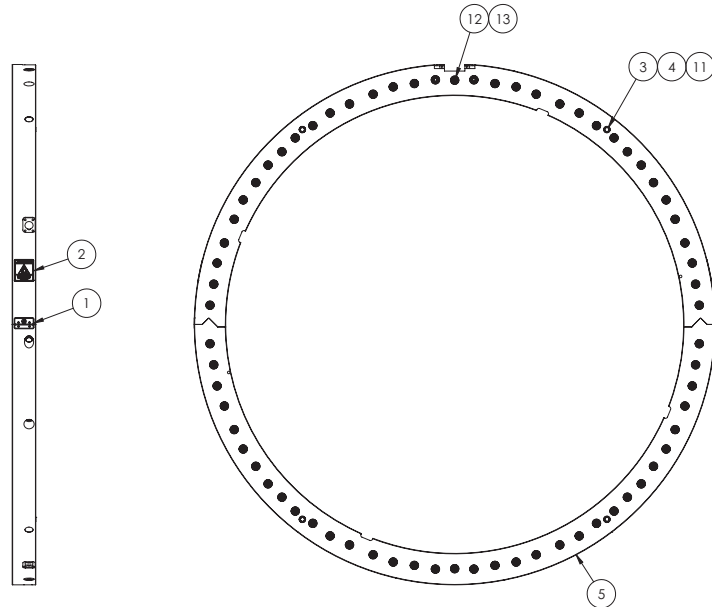
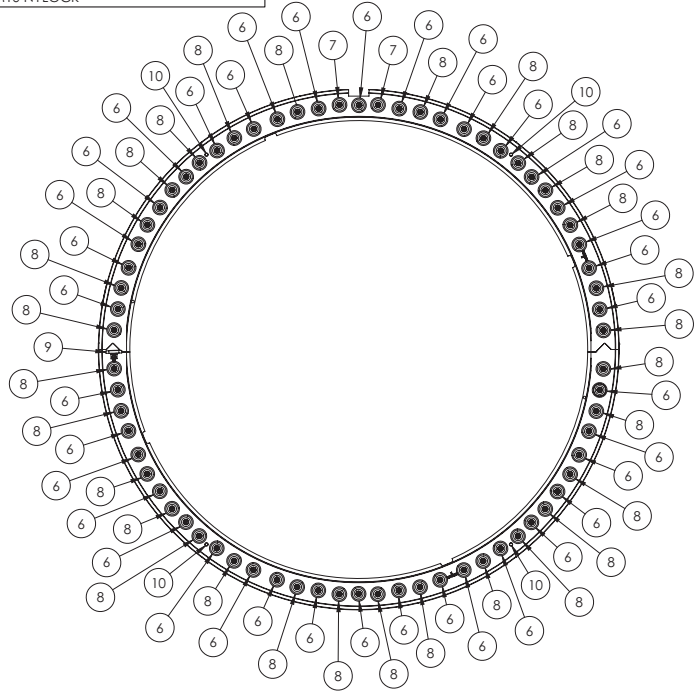
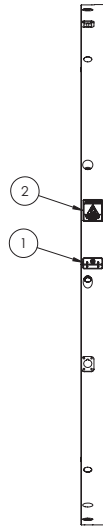
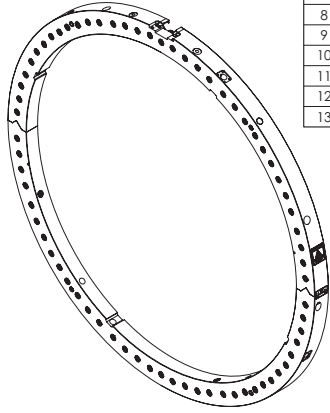

Ensemble du châssis fixe 60 po, 69-4001-60

Rev A

ITEM	PART NUMBER	QTY	DESCRIPTION
1	60-028-00	2	LABEL, NO GAPS
2	60-363-00	2	LABEL, MOVING PARTS
3	69-0073-00	4	SCREW, CAPTIVATED
4	69-0094-00	4	NUT, TRIP POSITIONING BAR
5	69-1200-60	1	RING, 60" STATIONARY FRAME
6	69-3048-00	38	ECCENTRIC BEARING ASSEMBLY, INSIDE
7	69-3049-00	2	STRAIGHT BEARING ASSEMBLY, OUTSIDE
8	69-3050-00	30	ECCENTRIC BEARING ASSEMBLY, OUTSIDE
9	69-3065-00	1	WIPER ASSEMBLY, 54" THRU 60"
10	69-8025-00	4	SPRING PLUNGER
11	69-8026-00	4	RING, RETAINING-SPIRAL
12	90-075-59	70	WASHER, 3/8 SECURING
13	90-1042-00	70	NUT, M10 NYLOCK

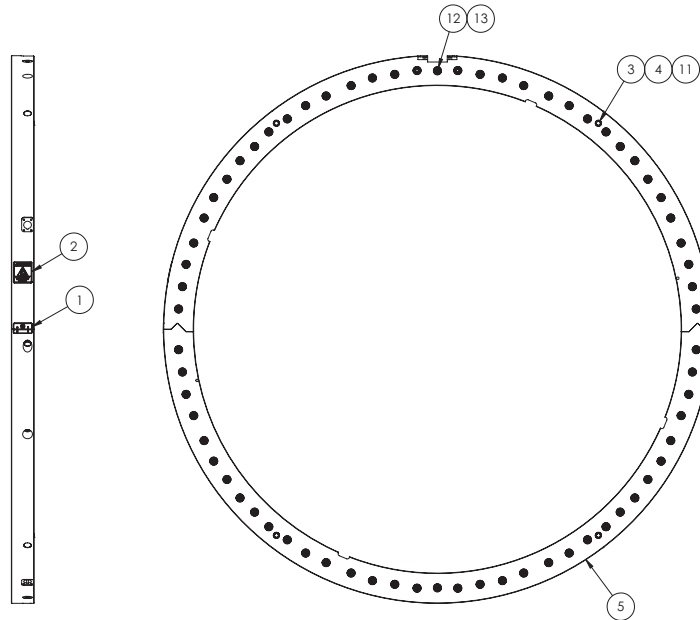
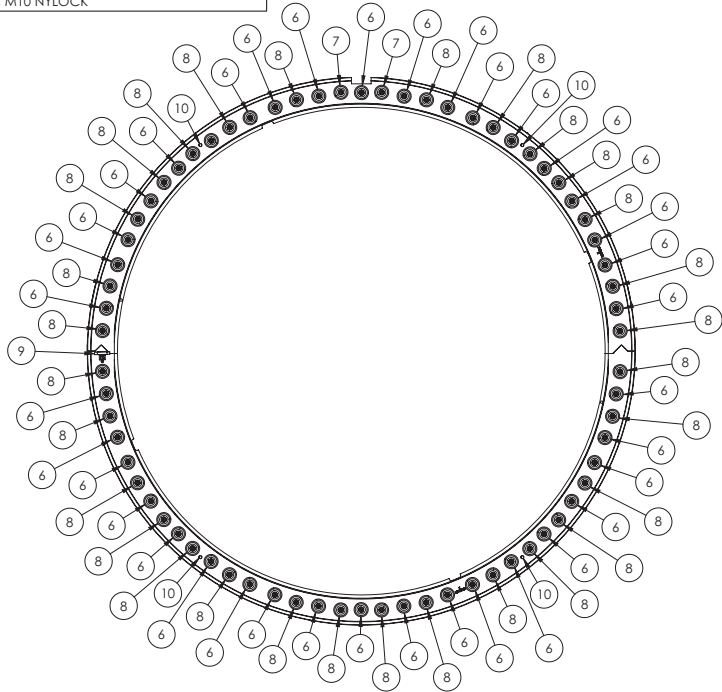
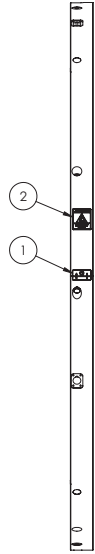
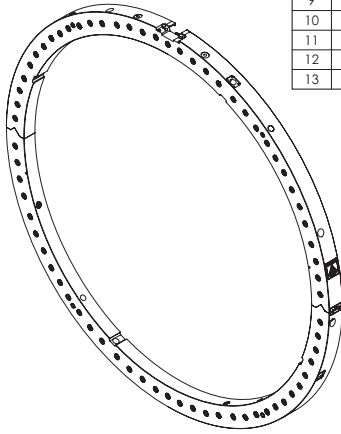

Pied de réglage axial, 69-3062-00

ITEM	PART NUMBER	QTY	DESCRIPTION
1	69-0062-00	1	LEG, ADJUSTABLE
2	69-0063-00	1	RETAINER
3	69-0064-00	1	SCREW, ADJUSTMENT
4	69-0065-00	1	NUT, AXIAL ADJUSTMENT
5	69-8015-00	1	O-RING, (-009) BUNA-N
6	90-1004-16	4	SHCS, M6 X 1MM X 16MM

REV A

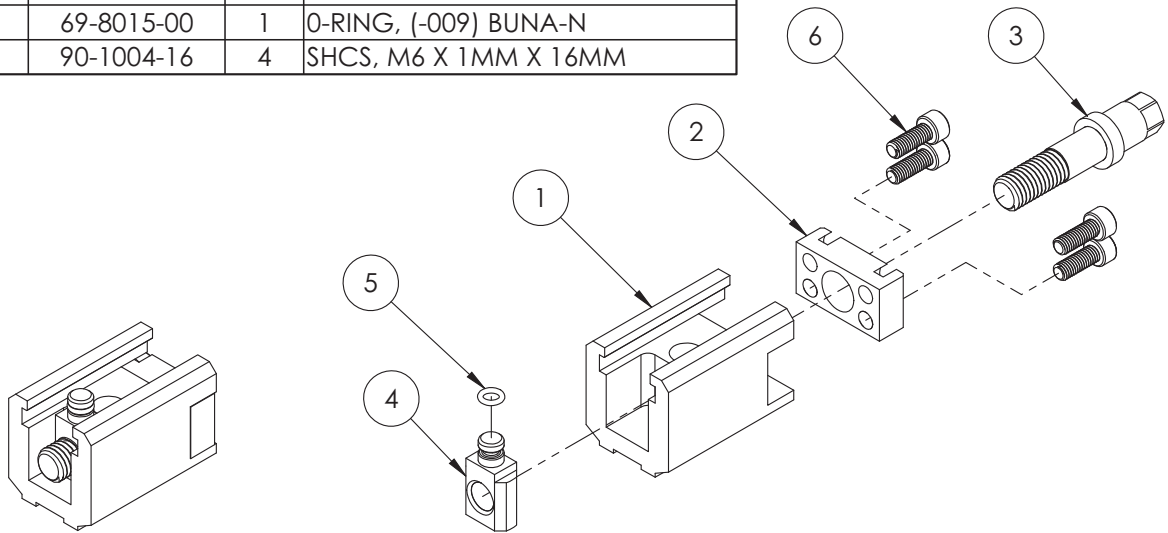

Ensemble de vis de bridage, 69-4500-02

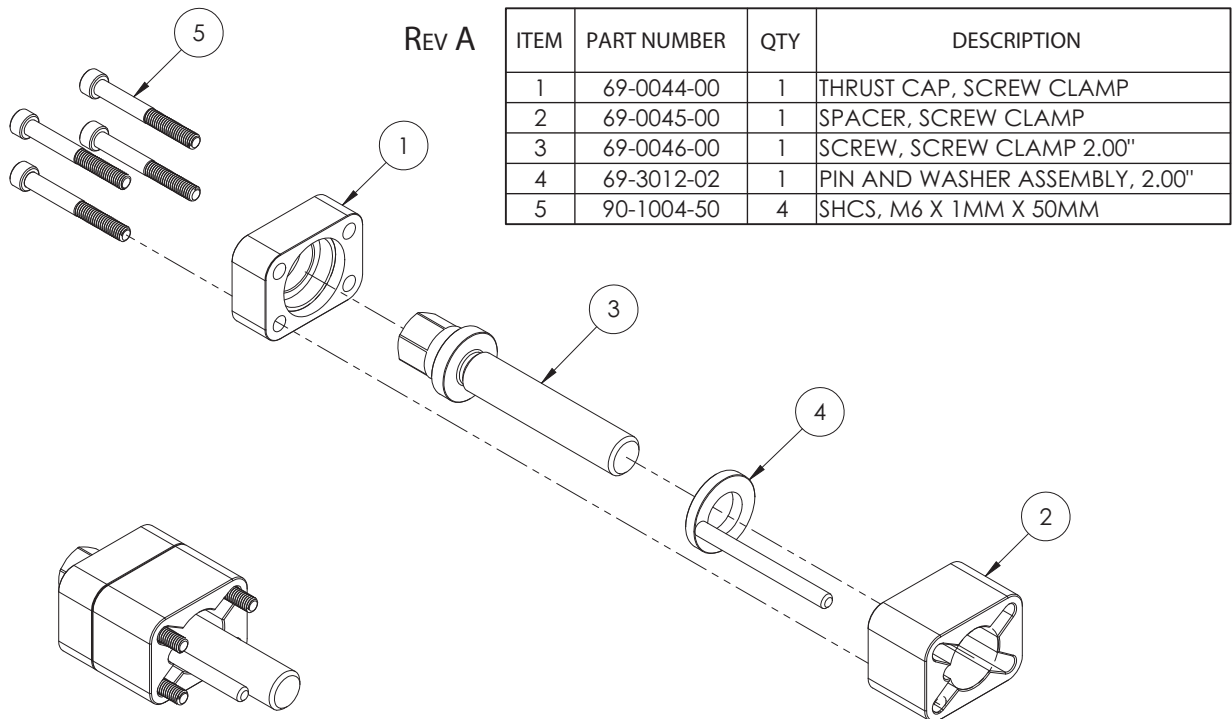

REV A

ITEM	PART NUMBER	QTY	DESCRIPTION
1	69-0044-00	1	THRUST CAP, SCREW CLAMP
2	69-0045-00	1	SPACER, SCREW CLAMP
3	69-0046-00	1	SCREW, SCREW CLAMP 2.00"
4	69-3012-02	1	PIN AND WASHER ASSEMBLY, 2.00"
5	90-1004-50	4	SHCS, M6 X 1MM X 50MM

Chapitre 4

Transmissions, adaptateur de transmission et accessoires d'alimentation



Ce chapitre contient les dessins et listes de pièces des différents éléments de transmission de la DynaPrep MDSF.

Ensemble pignon, 1/2" entraînement carré, 69-3025-01

ITEM	PART NUMBER	QTY	DESCRIPTION
1	69-0128-01	1	COVER, LEGACY PINION HOUSING
2	69-0129-01	1	PINION GEAR, 1/2" SQUARE INPUT
3	69-0130-01	1	HOUSING, LEGACY PINION
4	69-0188-00	4	SHCS, M8 X 1.25MM X 30MM CAPTIVATED
5	69-0243-00	1	FLANGE, PINION
6	69-0244-00	1	SPACER, PINION
7	69-8072-00	1	NUT, BEARING
8	69-8073-00	1	BEARING, 30MM ID X 62MM OD X 17.25 WIDE, ROLLER
9	69-8074-00	1	BEARING, 25MM ID X 47MM OD X 15MM WIDE, ROLLER
10	69-8075-00	1	SEAL, 30MM ID X 60MM OD X 3.6MM WIDE
11	69-8076-00	1	SEAL, 25MM ID X 46MM OD X 3.7MM WIDE
12	90-1004-16	2	SHCS, M6 X 1MM X 16MM
13	90-1023-10	6	SHCS, M4 X 0.7MM X 10MM

Rev A

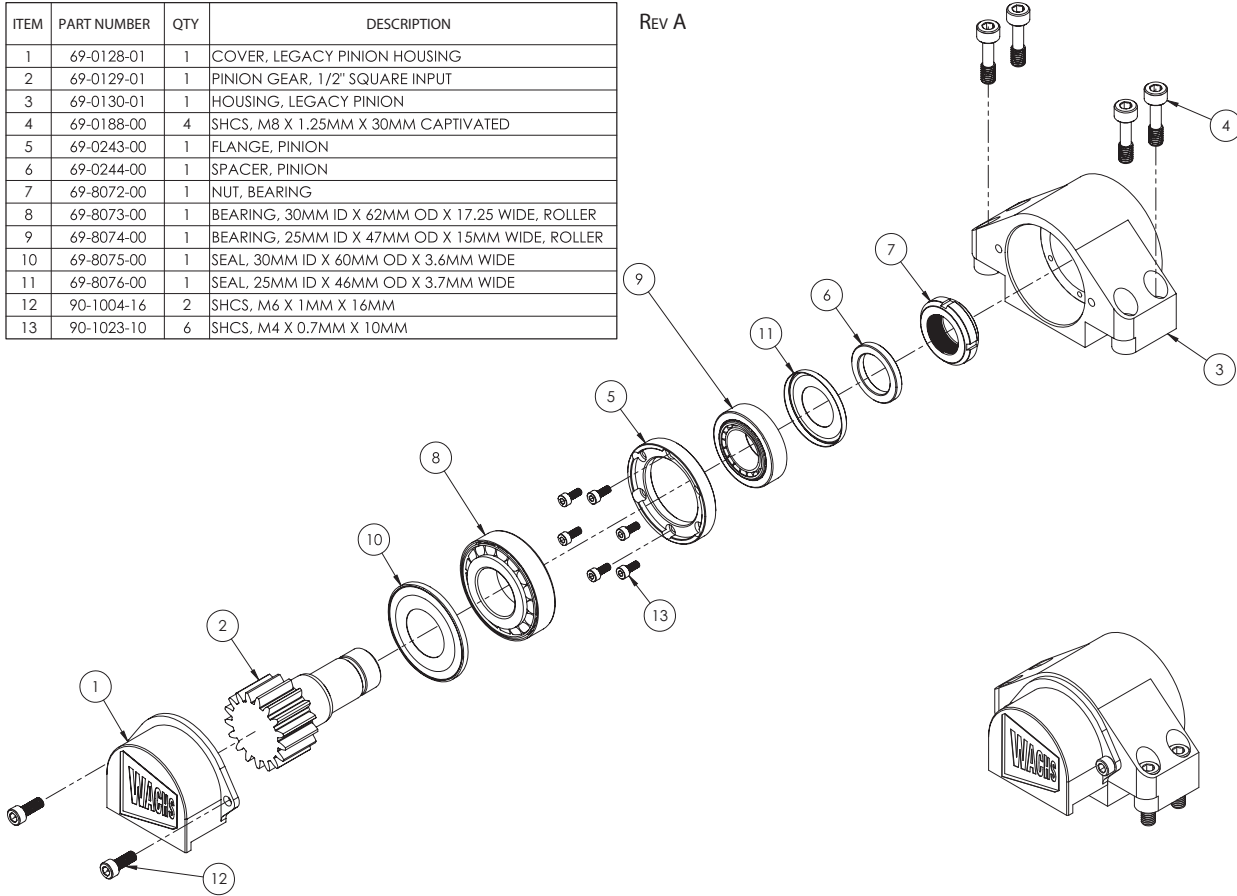

Sous-ensemble de transmission avant du pignon, 69-3038-00

ITEM	PART NUMBER	QTY	DESCRIPTION
1	69-0179-00	1	HOUSING, FRONT DRIVE
2	69-0180-00	1	GEAR, IDLER-FRONT DRIVE
3	69-0181-00	1	GEAR, PINION-FRONT DRIVE
4	69-0182-00	1	SHAFT, IDLER GEAR-FRONT DRIVE
5	69-0183-00	1	RETAINER, BEARING-FRONT DRIVE
6	69-0184-00	1	COVER, FRONT DRIVE
7	69-0188-00	4	SHCS, M8 X 1,25MM X 30MM CAPTIVATED
8	69-8036-00	1	BEARING, 40MM IS X 80MM OD X 30,2MM WIDE, CLEARANCE C2
9	69-8047-00	1	RING, RETAINING-EXTERNAL
10	69-8048-00	2	BEARING, 25MM X 52MM X 15MM
11	69-8049-00	1	RING, RETAINING-INTERNAL
12	69-8050-00	1	RING, RETAINING-EXTERNAL
13	90-1004-45	6	SHCS, M6 X 1MM X 45MM
14	90-1033-40	2	PIN, 8MM X 40MM DOWEL
15	90-1037-20	2	PIN, 5MM X 20MM DOWEL

Rev A

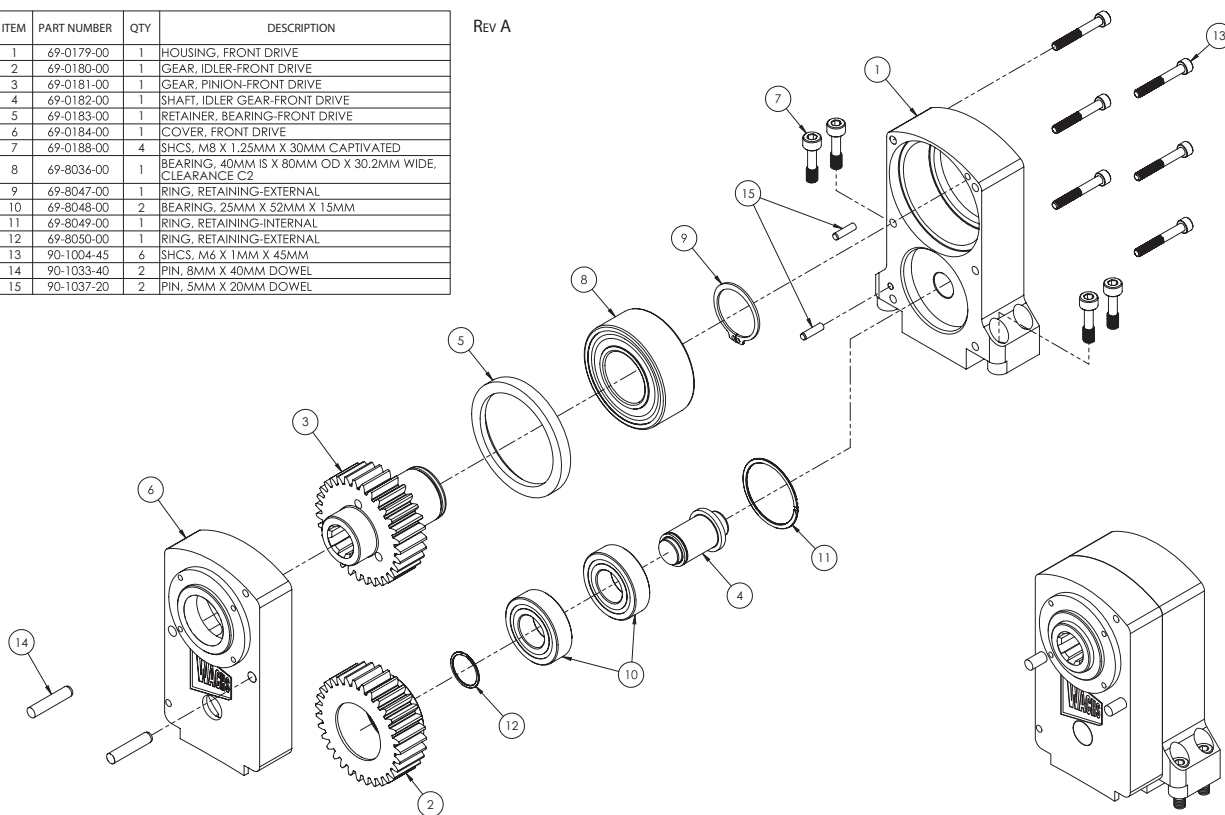

Ensemble de pignons traditionnels, 69-4480-01

Rev B	ITEM	PART NUMBER	QTY	DESCRIPTION
	1	69-0126-00	1	FACE GEAR, COUPLING
	2	69-0131-01	1	ADAPTER, LEGACY AIR MOTOR
	3	69-3025-01	1	PINION ASSEMBLY, 17 TOOTH, 1/2" SQ. DRIVE
	4	69-8037-00	1	CLAMP, RING TOGGLE
	5	90-060-07	2	SHCS, 5/16-18 X 3/4
	6	90-1018-16	4	BHCS, M5 X 0.8MM X 16MM

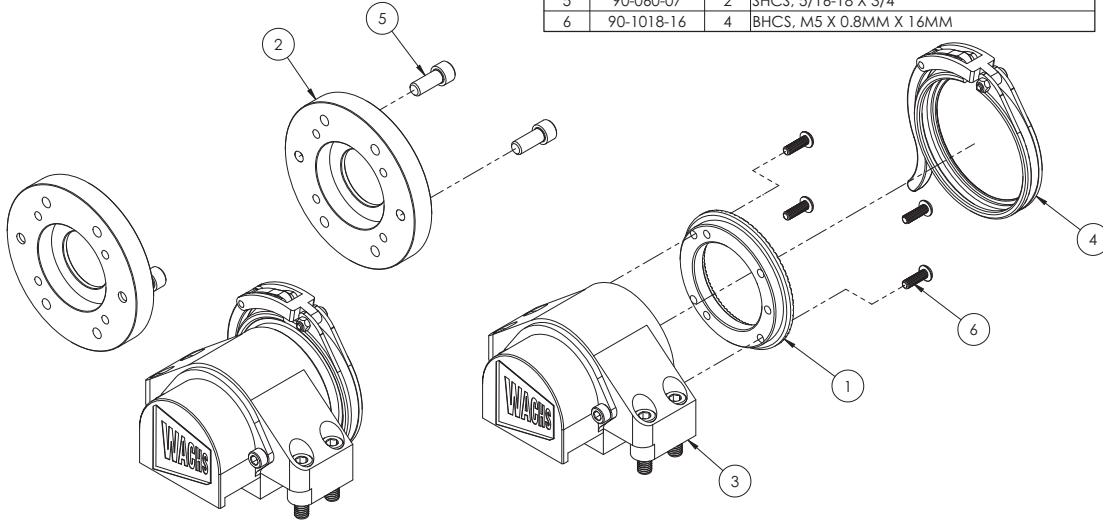

Ensemble de pignons traditionnels de la transmission avant, 69-4480-01

ITEM	PART NUMBER	QTY	DESCRIPTION
1	69-0126-00	1	FACE GEAR, COUPLING
2	69-0185-00	1	ADAPTER, AIR MOTOR-LEGACY FRONT DRIVE
3	69-3037-00	1	ADAPTER, 6B SPLINE TO 1/2 SQ-FRONT DRIVE
4	69-3038-00	1	PINION FRONT DRIVE SUB-ASSEMBLY, MDSF
5	69-8037-00	1	CLAMP, RING TOGGLE
6	90-060-07	2	SHCS, 5/16-18 X 3/4
7	90-1018-16	4	BHCS, M5 X 0.8MM X 16MM

Rev B

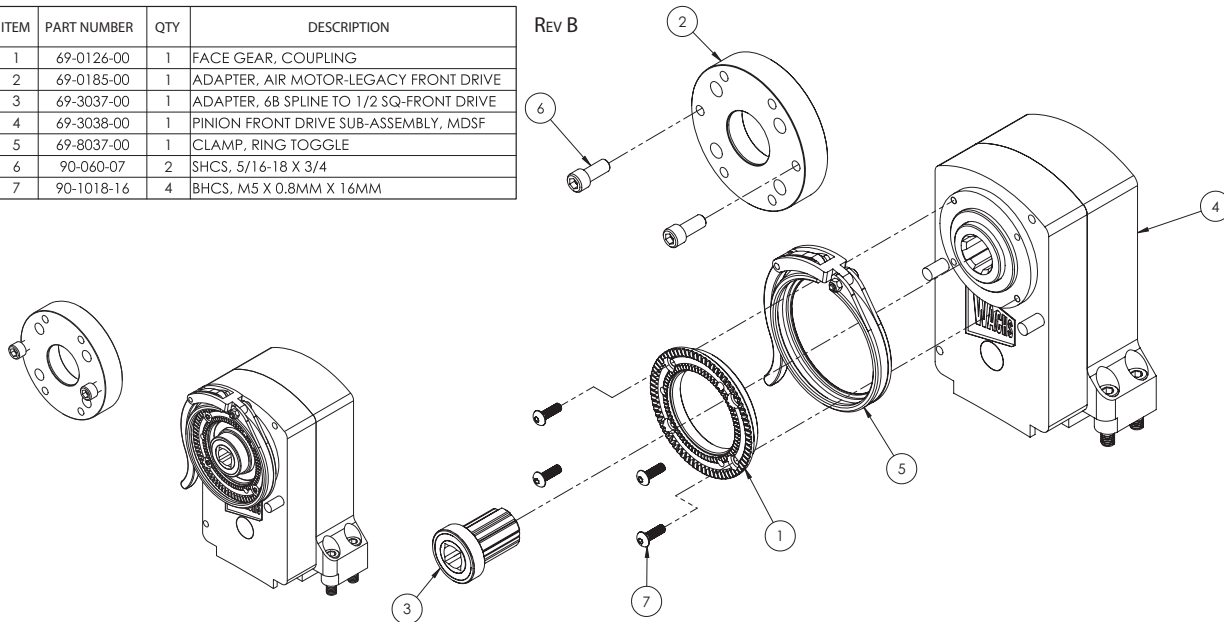

Ensemble de pignons standard, 69-4482-01

ITEM	PART NUMBER	QTY	DESCRIPTION
1	69-0123-01	1	HOUSING, PINION
2	69-0124-01	1	GEAR, PINION
3	69-0125-00	1	COVER, PINION HOUSING
4	69-0126-00	1	FACE GEAR, COUPLING
5	69-0188-00	4	SHCS, M8 X 1.25MM X 30MM CAPTIVATED
6	69-0245-00	1	SPACER, PINION
7	69-0246-00	1	FLANGE, PINION
8	69-8037-00	1	CLAMP, RING TOGGLE
9	69-8077-00	1	NUT, BEARING
10	69-8078-00	2	BEARING, 40MM ID X 80MM OD X 19.75MM WIDE, ROLLER
11	69-8079-00	2	SEAL, 40MM ID X 77.5MM OD X 4.1MM WIDE
12	90-1004-14	6	SHCS, M6 X 1MM X 14MM
13	90-1004-16	2	SHCS, M6 X 1MM X 16MM
14	90-1018-16	4	BHCS, M5 X 0.8MM X 16MM

Rev A

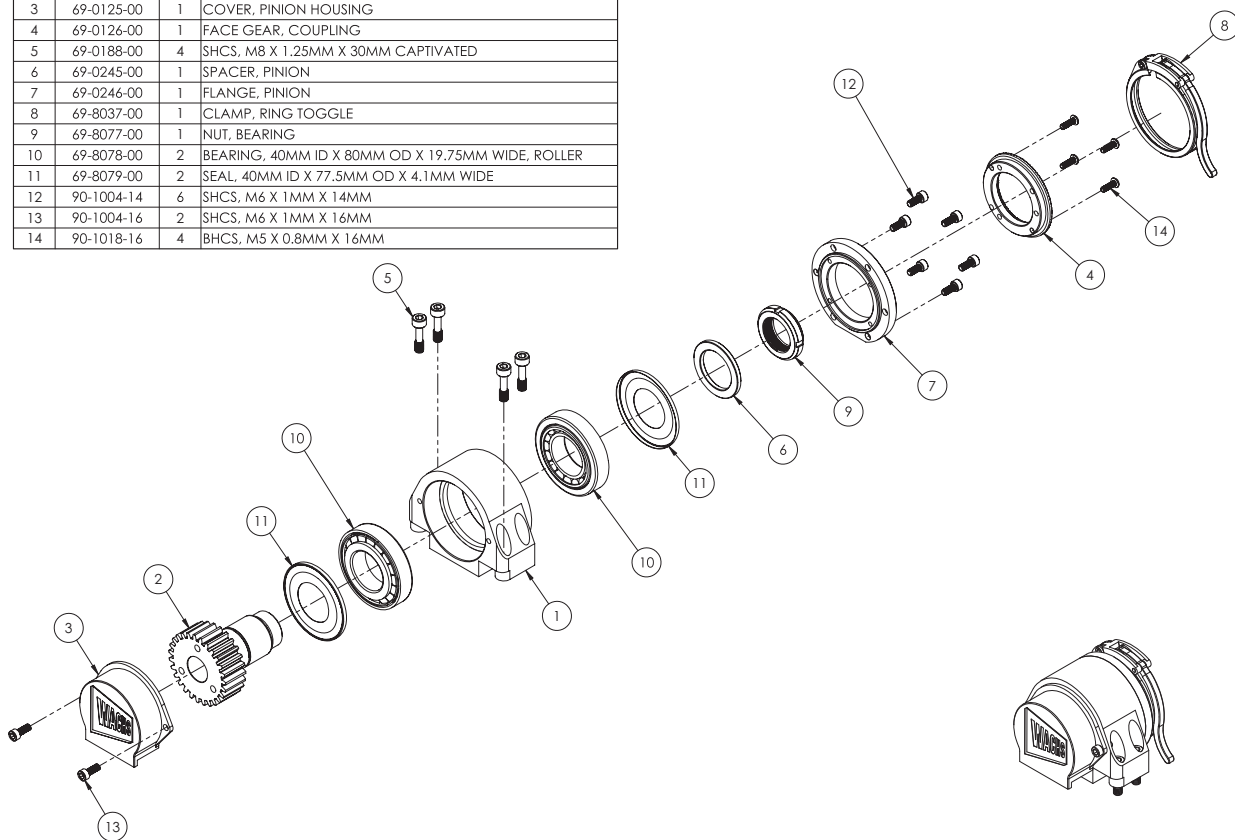

Moteur, transmission pneumatique 3 cv, 69-4351-00

REV C

ITEM	PART NUMBER	QTY	DESCRIPTION
1	66-100-00	1	VALVE, FLOW CONTROL
2	69-0126-00	1	FACE GEAR, COUPLING
3	69-0142-00	1	MODEC AIR MOTOR-MR25RT0133QCA1F
4	90-098-68	1	ADAPTER, 1/2 NPT M X 3/8 NPT M-STRAIGHT
5	90-218-32	1	COUPLING, 1/2 M-NPT CHICAGO
6	90-401-02	1	LABEL, PRESSURE-AIR
7	90-401-03	1	LABEL, EAR AND EYE PROTECTION
8	90-401-04	1	LABEL, CRUSH AND CUT
9	90-405-00	1	LABEL, LUBRICATED AIR

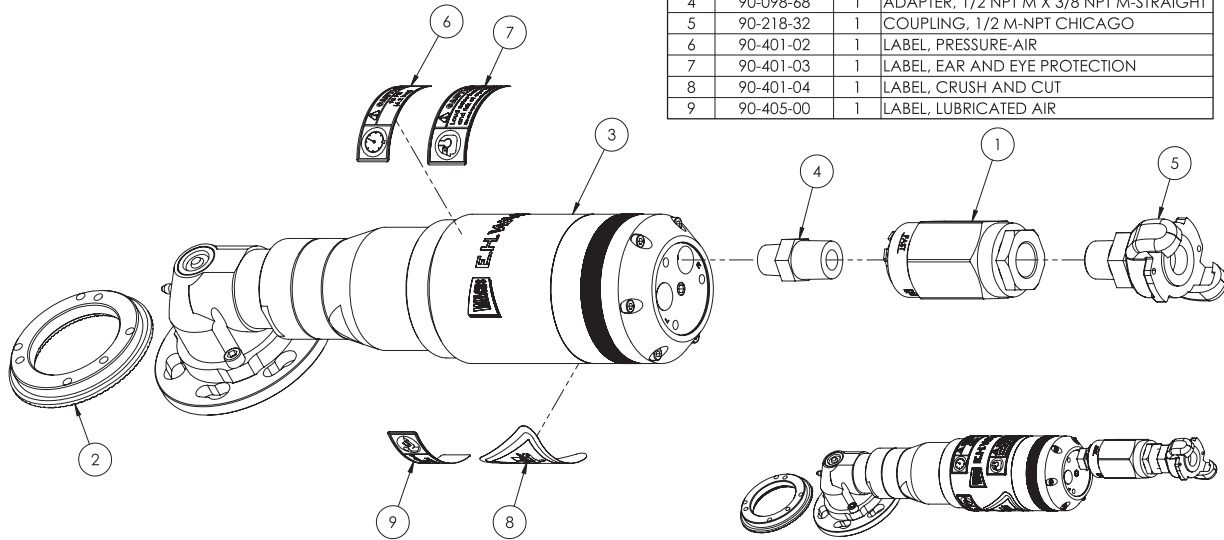

Moteur, transmission pneumatique 1,5 cv à renvoi d'angle (CE), 69-4352-00

ITEM	PART NUMBER	QTY	DESCRIPTION
1	60-211-00	1	CLECO AIR MOTOR (55NL-3T-960)
2	60-1311-00	1	STRAP, 9" VELCRO CINCH
3	66-100-00	1	VALVE, FLOW CONTROL
4	69-0126-00	1	FACE GEAR, COUPLING
5	69-0237-00	1	ADAPTER, 1.5 HP CLECO AIR MOTOR
6	69-0238-00	1	FLANGE, 1.5 HP CLECO AIR MOTOR
7	90-098-01	1	NIPPLE, 1/2 X CLOSE
8	90-218-32	1	COUPLING, 1/2 M-NPT CHICAGO
9	90-1023-06	6	SHCS, M4 X 0.7MM X 6MM
10	90-1040-12	3	BHCS, M6 X 1.0MM X 12MM

Rev A

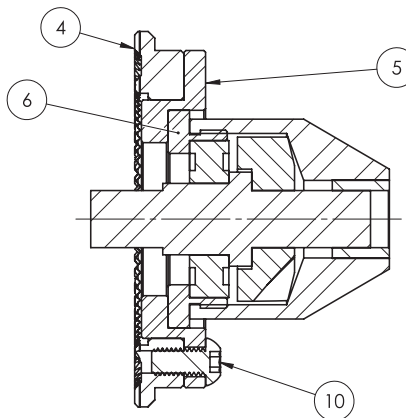

SECTION A-A

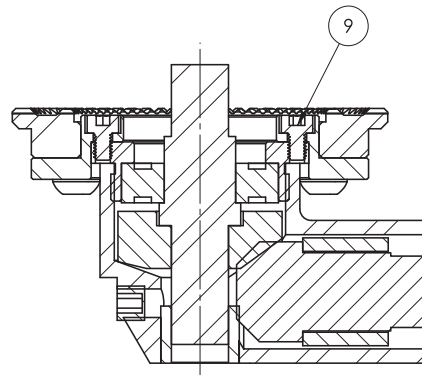
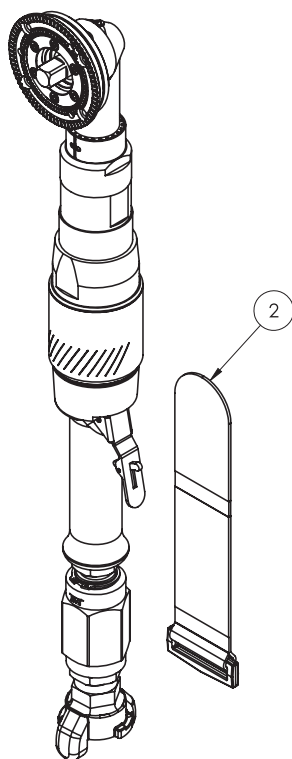

SECTION B-B

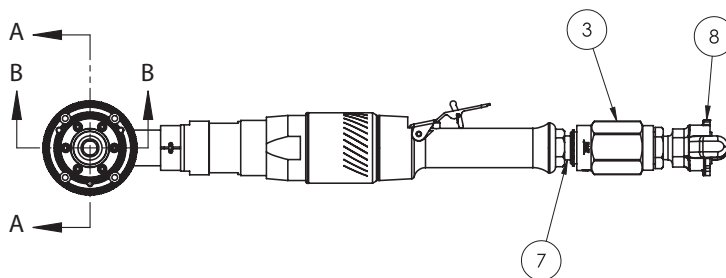
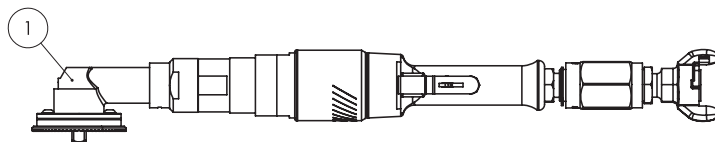

Moteur, transmission pneumatique 1,5 cv à renvoi d'angle avec poignée, 69-4354-00

ITEM	PART NUMBER	QTY	DESCRIPTION
1	05-082-00	1	OILER, AIR LINE
2	60-211-00	1	CLECO AIR MOTOR (55NL-3T-960)
3	66-100-00	1	VALVE, FLOW CONTROL
4	69-0126-00	1	FACE GEAR, COUPLING
5	69-0237-00	1	ADAPTER, 1.5 HP CLECO AIR MOTOR
6	69-0238-00	1	FLANGE, 1.5 HP CLECO AIR MOTOR
7	90-098-01	2	NIPPLE, 1/2 X CLOSE
8	90-1023-06	6	SHCS, M4 X 0.7MM X 6MM
9	90-1040-12	3	BHCS, M6 X 1.0MM X 12MM

Rev A

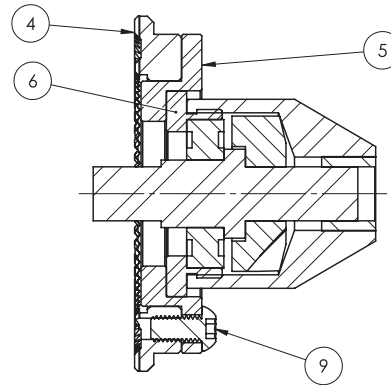
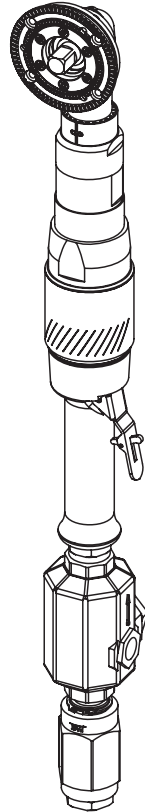

SECTION A-A

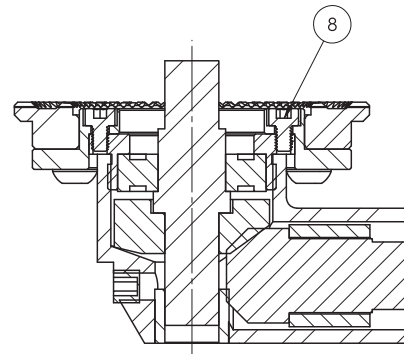

SECTION B-B

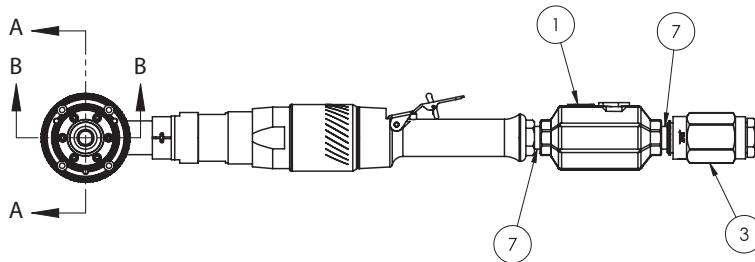
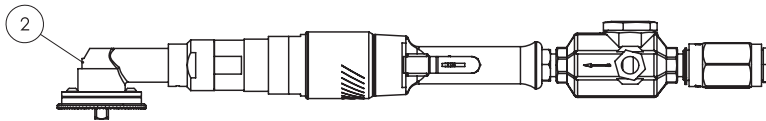

Moteur, transmission pneumatique 4 cv, 69-4355-00

REV D

ITEM	PART NUMBER	QTY	DESCRIPTION
1	66-100-00	1	VALVE, FLOW CONTROL
2	69-0126-00	1	FACE GEAR, COUPLING
3	69-0137-00	1	MODEC AIR MOTOR-MT30RT0095WCNWF
4	90-218-32	1	COUPLING, 1/2 M-NPT CHICAGO
5	90-401-02	1	LABEL, PRESSURE-AIR
6	90-401-03	1	LABEL, EAR AND EYE PROTECTION
7	90-401-04	1	LABEL, CRUSH AND CUT
8	90-405-00	1	LABEL, LUBRICATED AIR
9	90-1018-16	4	BHCS, M5 X 0.8MM X 16MM
10	90-1980-00	1	ADAPTER, 1/2 BSPP MALE X 1/2 NPT MALE

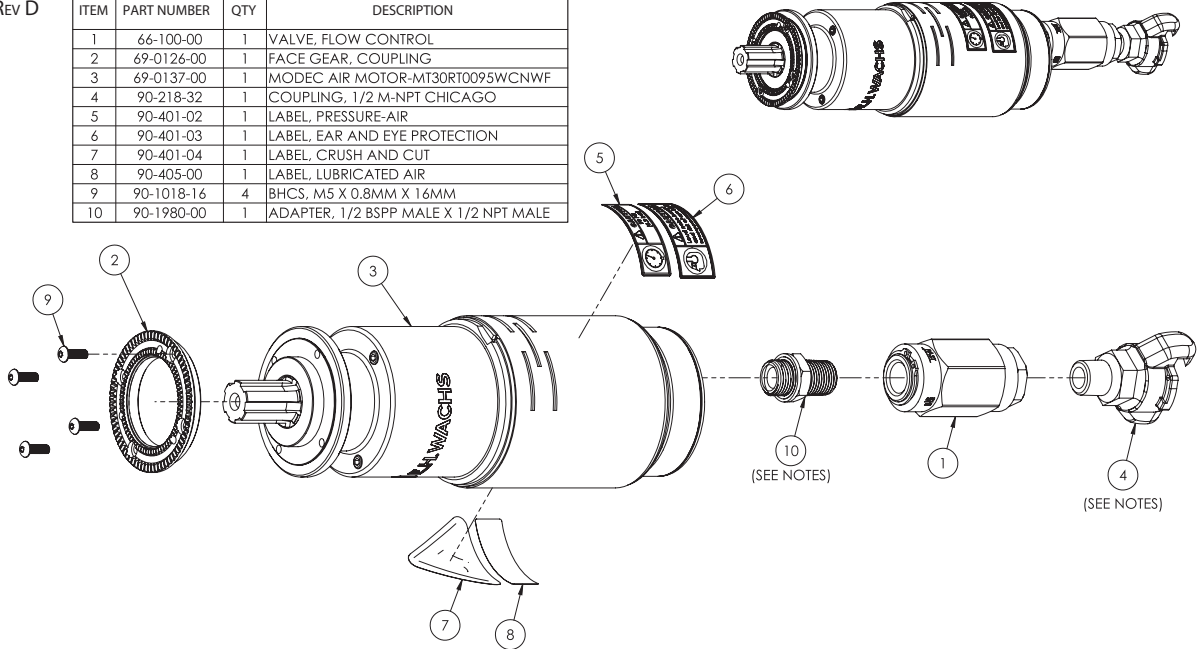

Moteur, transmission pneumatique 3 cv avec poignée, 69-4353-01

REV A

ITEM	PART NUMBER	QTY	DESCRIPTION
1	66-100-00	1	VALVE, FLOW CONTROL
2	69-0126-00	1	FACE GEAR, COUPLING
3	69-0260-00	1	MODEC AIR MOTOR, NR25RV0122QCA1F-W
4	90-218-32	1	COUPLING, 1/2 M-NPT CHICAGO
5	90-401-02	1	LABEL, PRESSURE-AIR
6	90-401-03	1	LABEL, EAR AND EYE PROTECTION
7	90-401-04	1	LABEL, CRUSH AND CUT
8	90-405-00	1	LABEL, LUBRICATED AIR
9	90-1980-00	1	ADAPTER, 1/2 BSPP MALE X 1/2 NPT MALE

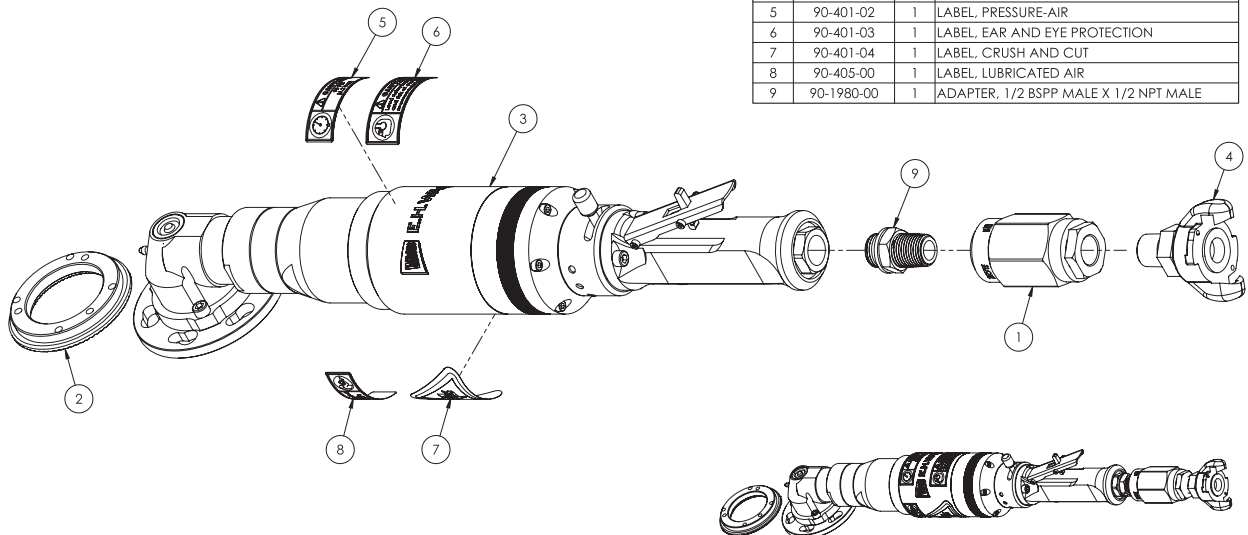

Ensemble moteur à transmission pneumatique 3 cv, 69-3030-00

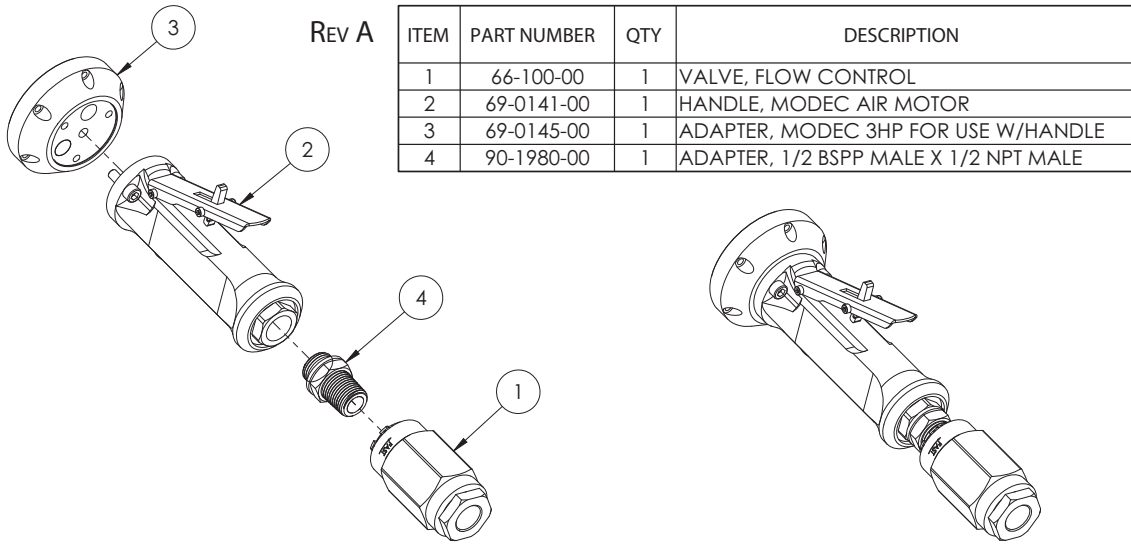

Moteur, transmission pneumatique 4 cv avec poignée, 69-4356-00

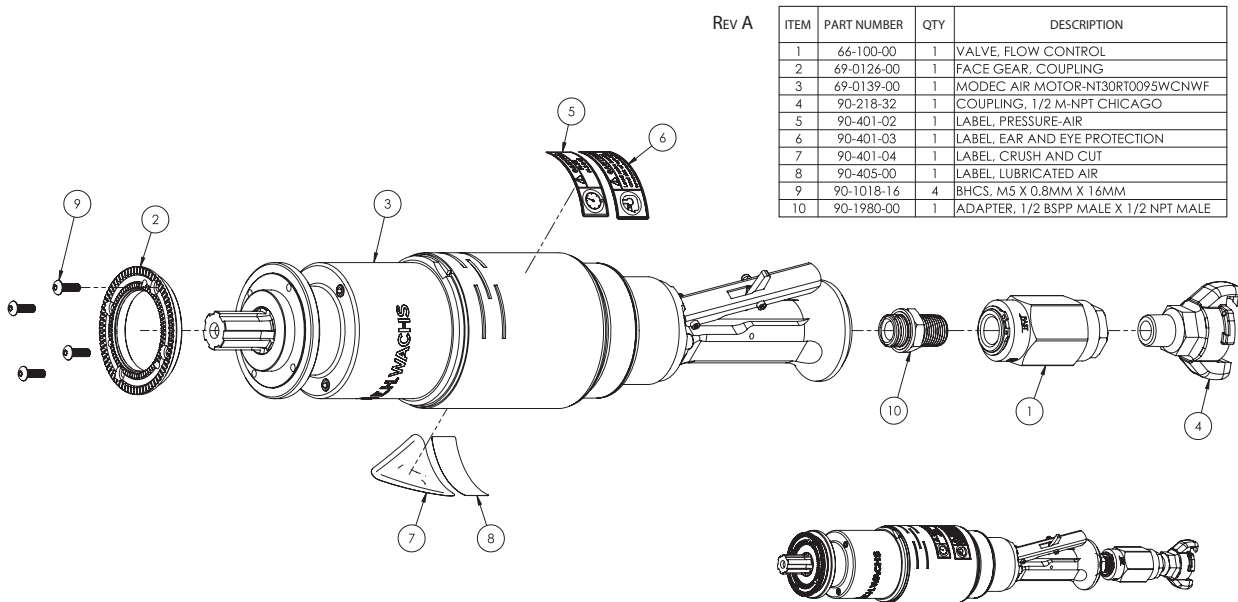

Ensemble moteur à transmission pneumatique 4 cv, 69-3028-00

REV A

ITEM	PART NUMBER	QTY	DESCRIPTION
1	66-100-00	1	VALVE, FLOW CONTROL
2	69-0230-00	1	HANDLE, MODEC AIR MOTOR 4HP
3	90-218-32	1	COUPLING, 1/2 M-NPT CHICAGO
4	90-1980-00	1	ADAPTER, 1/2 BSPP MALE X 1/2 NPT MALE

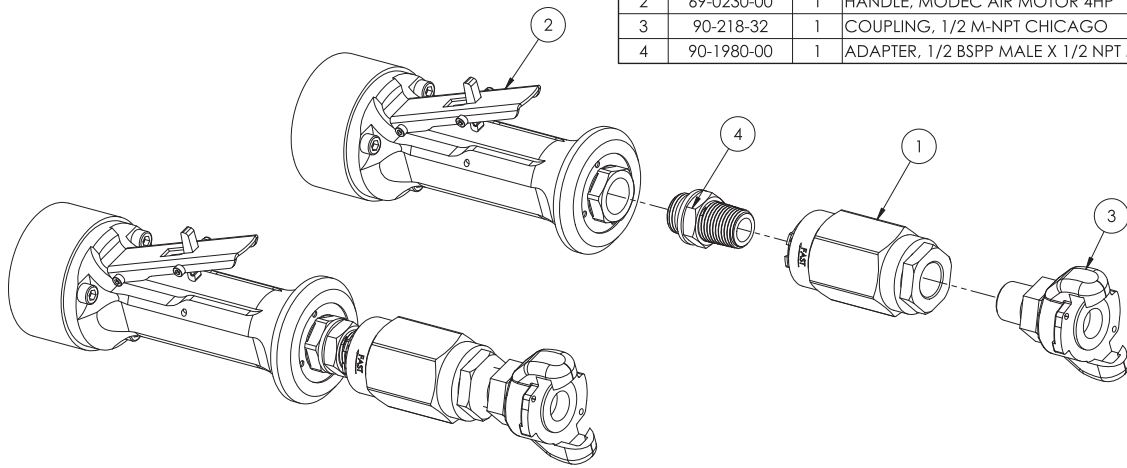

Module pneumatique d'utilisation à distance, 69-4101-00

ITEM	PART NUMBER	QTY	DESCRIPTION
1	69-0213-00	1	LABEL, ACM
2	69-3043-00	1	3/4" HOSE AND COUPLING ASSEMBLY, ATM
3	69-3056-00	1	HAND PENDANT ASSEMBLY
4	69-3061-00	1	ACM AND BRACKET ASSEMBLY
5	69-8052-00	1	TOOL BOX, 22" PRO
6	90-404-01	1	LABEL, GENERAL PRODUCTS 5.5" X 2.5"

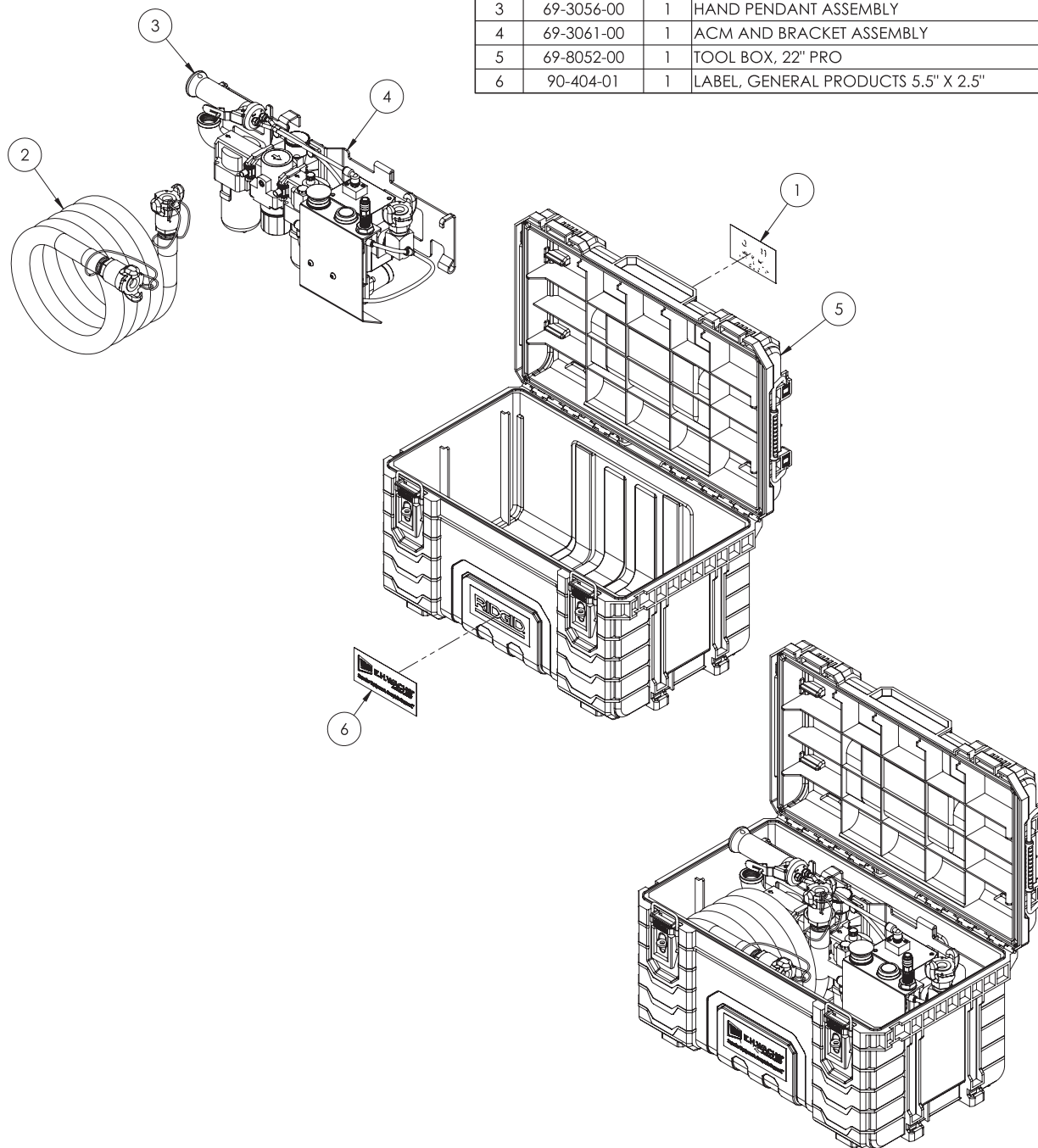

ACM et ensemble de supports, 69-3061-00

ITEM	PART NUMBER	QTY	DESCRIPTION	REV A
1	69-0216-00	1	GUARD	
2	69-0220-00	1	MOUNTING PLATE, FRL/ACM	
3	69-3059-00	1	START/STOP MTG. PLATE ASSEMBLY	
4	69-3060-00	1	FRL AND AIR PILOT ASSEMBLY	
5	69-8067-00	2	SPACER, M6 SCREW SIZE X 45MM LG.	
6	69-8069-00	1	SPACER, 1/4 SCREW SIZE X 1-5/16 LG.	
7	90-055-53	1	WASHER, 1/4 FLAT	
8	90-061-08	4	HHCS, 5/16-18 X 7/8	
9	90-065-03	4	NUT, 5/16-18 NYLOCK	
10	90-065-53	4	WASHER, 5/16 AN	
11	90-902-04	A/R	TUBING, 6MM OD X 4MM ID POLYURETHANE	
12	90-1040-45	1	BHCS, M6 X 1.0MM X 45MM	
13	90-1040-55	2	BHCS, M6 X 1.0MM X 55MM	

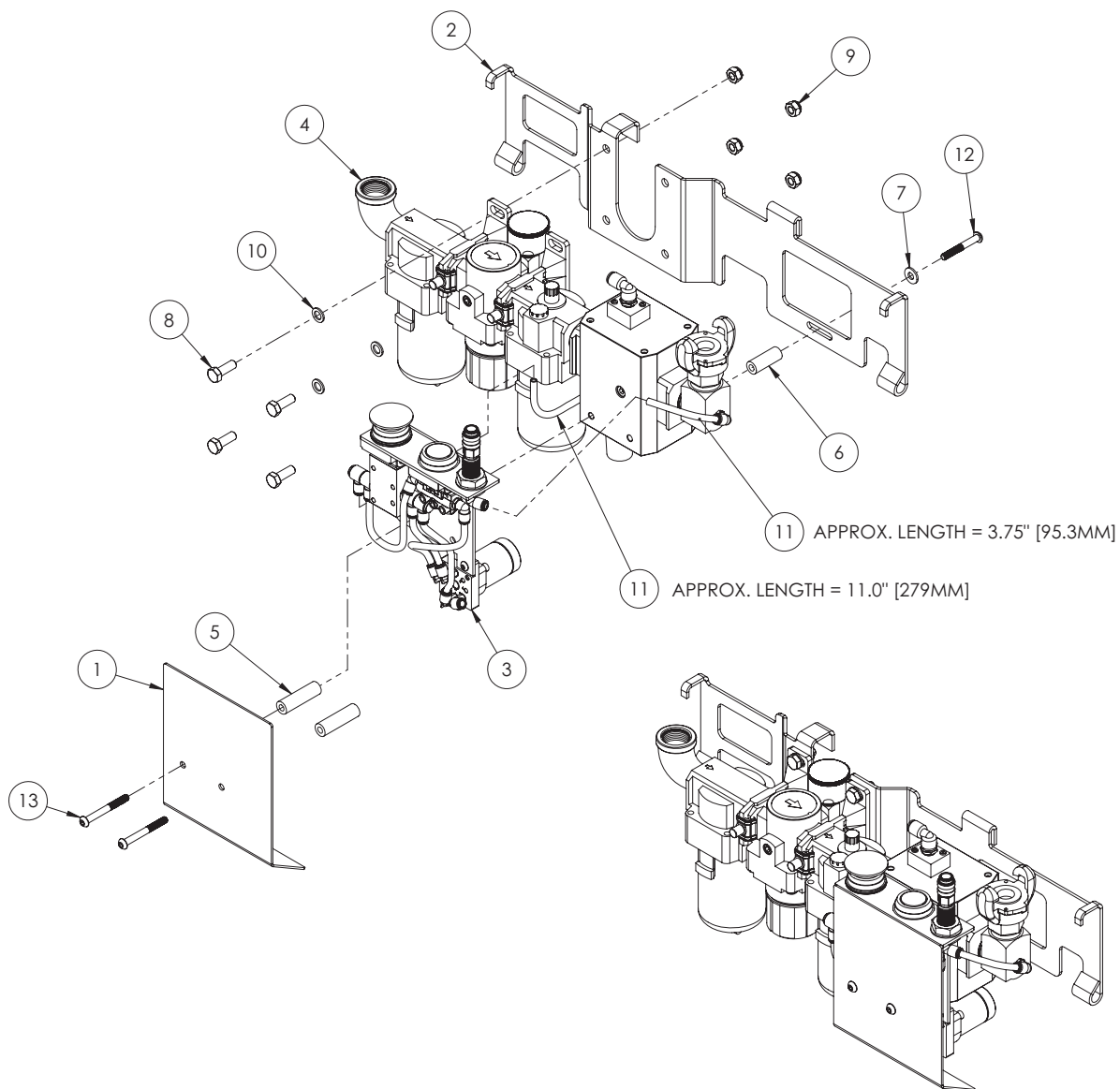

Ensemble plaque de montage Marche/arrêt, 69-3059-00

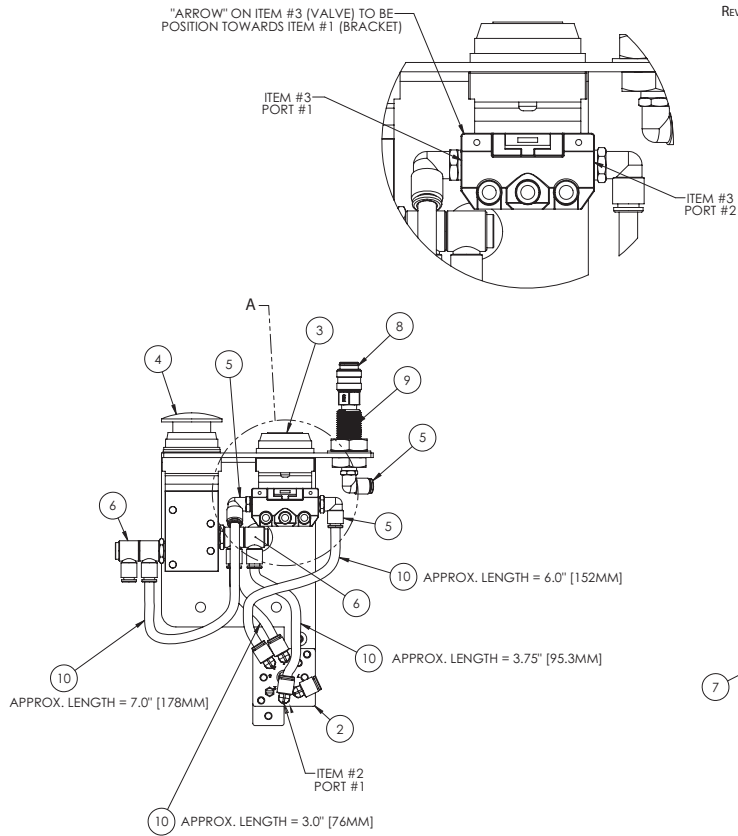

Rev B

ITEM	PART NUMBER	QTY	DESCRIPTION
1	69-0214-00	1	MOUNTING PLATE, E-STOP
2	69-3058-00	1	RESET VALVE ASSEMBLY
3	69-8064-00	1	VALVE, MECHANICAL
4	69-8065-00	1	POPPET VALVE, MECHANICAL
5	90-038-08	3	FITTING, MALE ELBOW 6MM, 1/8RPT
6	90-038-10	2	FITTING, DOUBLE UNIVERSAL MALE ELBOW
7	90-042-04	1	BHCS, 10-32 X 3/8
8	90-078-24	1	QD COUPLING, 1/8" (F) X 1/8" NPT (M)
9	90-078-30	1	COUPLING, THROUGH WALL-BRASS
10	90-902-04	A/R	TUBING, 6MM OD X 4MM ID POLYURETHANE

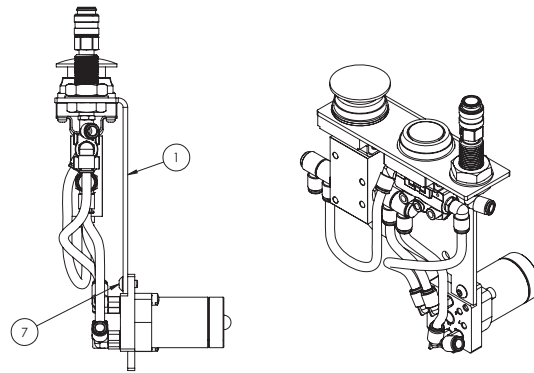

Module de traitement de l'air, 69-4102-00

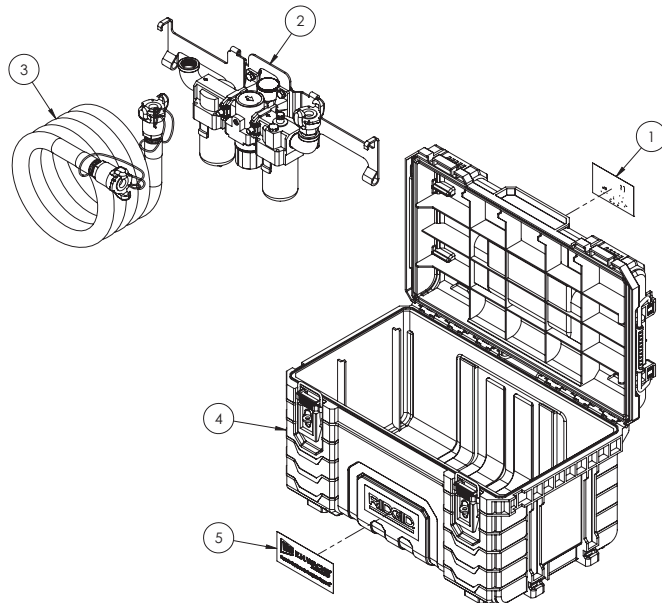

Rev A

ITEM	PART NUMBER	QTY	DESCRIPTION
1	69-0192-00	1	LABEL, ATM
2	69-3042-00	1	FRL AND BRACKET ASSEMBLY
3	69-3043-00	1	3/4" HOSE AND COUPLING ASSEMBLY, ATM
4	69-8052-00	1	TOOL BOX, 22" PRO
5	90-404-01	1	LABEL, GENERAL PRODUCTS 5.5" X 2.5"

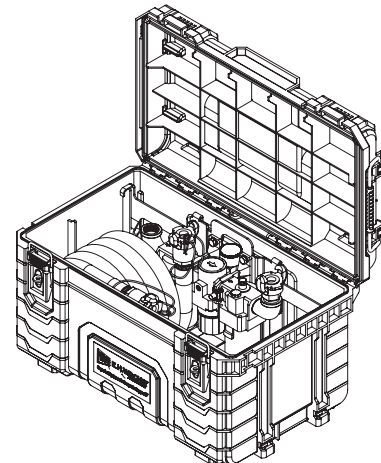

FRL et ensemble de supports, 69-3042-00

REV A

ITEM	PART NUMBER	QTY	DESCRIPTION
1	69-0195-00	1	MOUNTING PLATE, FRL
2	69-8054-00	1	F.R.L. UNIT
3	69-8055-00	1	GAUGE, PRESSURE-ATM
4	90-061-08	4	HHCS, 5/16-18 X 7/8
5	90-065-03	4	NUT, 5/16-18 NYLOCK
6	90-065-53	4	WASHER, 5/16 AN
7	90-098-16	1	ADAPTER, 1/8 NPT F X 1/8 NPT M X 90-DEG.
8	90-218-04	2	ELBOW, 3/4" 90-DEG. LP STREET
9	90-218-34	1	COUPLING, 3/4 M-NPT CHICAGO

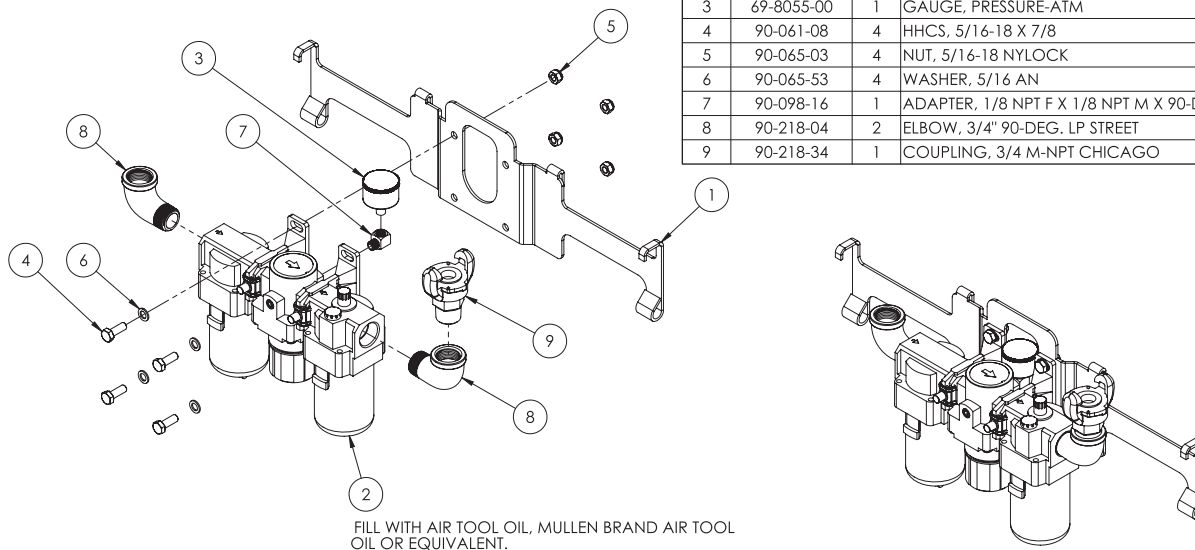

FILL WITH AIR TOOL OIL, MULLEN BRAND AIR TOOL OIL OR EQUIVALENT.

Transmission hydraulique complète, 69-4358-00

ITEM	PART NUMBER	QTY	DESCRIPTION
1	69-0126-00	1	FACE GEAR, COUPLING
2	69-0135-00	1	PLATE, ADAPTOR
3	69-3026-00	1	HYDRAULIC MANIFOLD SUB-ASSEMBLY
4	69-8038-00	1	HYDRAULIC MOTOR
5	90-065-52	4	WASHER, 5/16 FLAT
6	90-078-67	2	O-RING -112
7	90-402-02	1	LABEL, PRESSURE-HYD. 1500 PSI
8	90-1002-90	4	HHCS, M8 X 1.25MM X 90MM
9	90-1013-02	2	NUT, M12 NYLOCK
10	90-1018-14	4	BHCS, M5 X 0.8MM X 14MM
11	90-1029-40	2	FHCS, M12 X 1.75MM X 40MM

Rev B

NOTES:

1. -112 (BUNA-N) O-RING COMES WITH HYDRAULIC MOTOR FOR REPLACEMENTS CONTACT E.H. WACHS PART NUMBER: 90-078-67
2. WEIGHT: TBD
3. MAXIMUM FLOW: 15 GPM [56.8 LPM]
4. MAXIMUM PRESSURE: 1500 PSI [103 BAR]

PERFORMANCE DATA @ 1000 PSI [69 BAR]	
FLOW GPM [LPM]	RPM
2 [7.6]	47
4 [15.1]	94
6 [22.7]	141
8 [30.3]	188
10 [37.9]	235
12 [45.4]	282
14 [53.0]	330
15 [56.8]	353

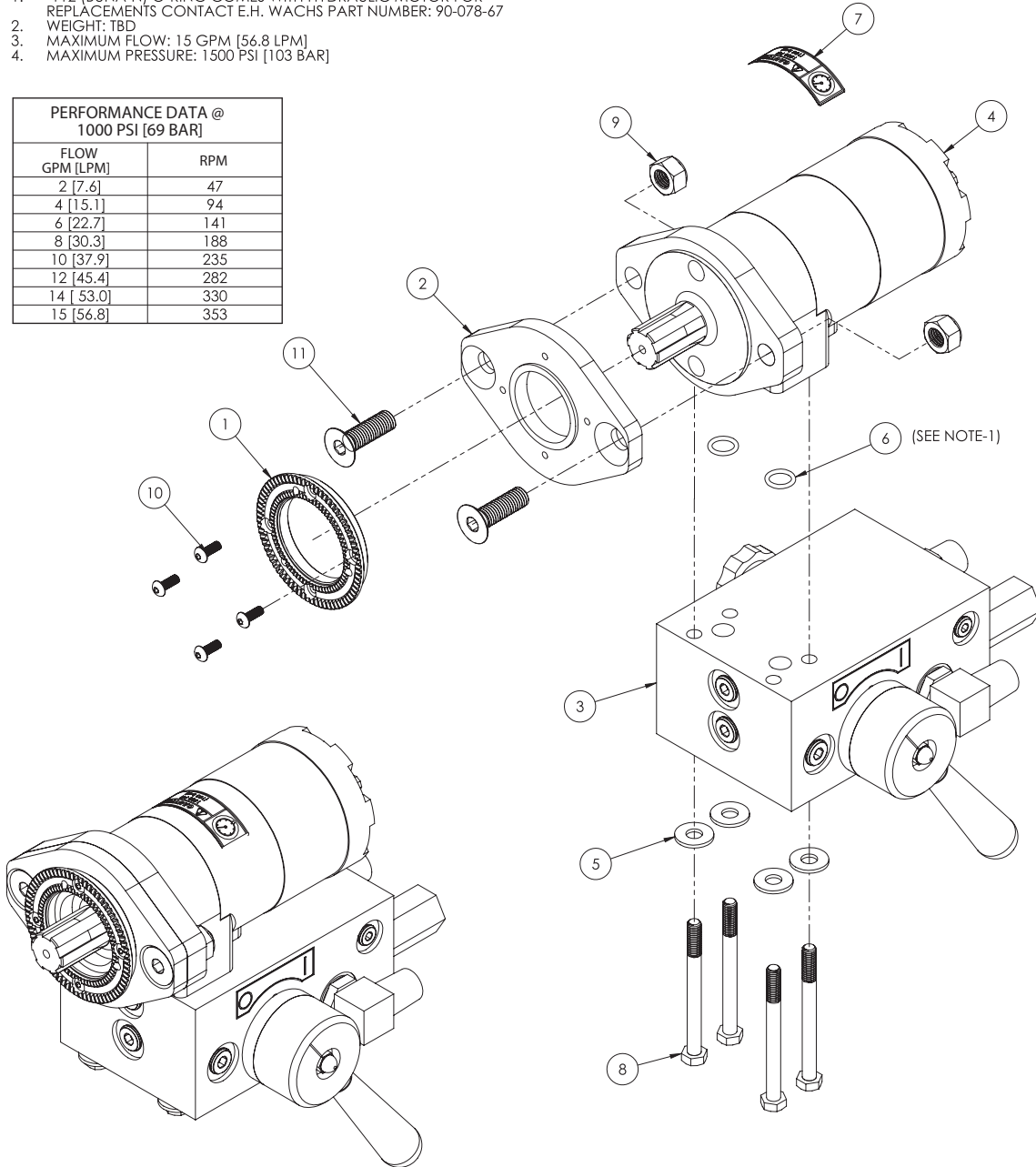

Ensemble transmission hydraulique, utilisation à distance, 69-4358-01

ITEM	PART NUMBER	QTY	DESCRIPTION
1	09-025-00	1	QUICK DISCONNECT, FEMALE
2	09-026-00	1	QUICK DISCONNECT-MALE
3	09-027-00	1	DUST CAP, MALE QUICK-DISCONNECT
4	09-028-00	1	DUST CAP, FEMALE QUICK-DISCONNECT
5	60-199-02	1	MANIFOLD
6	69-0126-00	1	FACE GEAR, COUPLING
7	69-0135-00	1	PLATE, ADAPTOR
8	69-8038-00	1	HYDRAULIC MOTOR
9	90-061-20	4	HHCS 5/16-18 X 2
10	90-065-53	4	WASHER, 5/16 AN
11	90-078-67	2	O-RING -112
12	90-088-86	2	PLUG, -06 ZERO-LEAK ORB
13	90-098-79	2	ADAPTER, 1/2 NPT M X 1/2 ORB M - STRAIGHT
14	90-401-01	1	LABEL, EYE PROTECTION
15	90-402-02	1	LABEL, PRESSURE-HYD. 1500 PSI
16	90-403-02	1	LABEL, BURN HAZARD/HOT SURFACE
17	90-1013-02	2	NUT, M12 NYLOCK
18	90-1018-14	4	BHCS, M5 X 0.8MM X 14MM
19	90-1029-40	2	FHCS, M12 X 1.75MM X 40MM

NOTES:

1. -112 (BUNA-N) O-RING COMES WITH HYDRAULIC MOTOR FOR REPLACEMENTS CONTACT E.H. WACHS PART NUMBER: 90-078-67
2. MAXIMUM FLOW: 15 GPM [56.8 LPM]
3. MAXIMUM PRESSURE: 1500 PSI [103 BAR]

PERFORMANCE DATA @ 1000 PSI [69 BAR]	
FLOW GPM [LPM]	RPM
2 [7.6]	47
4 [15.1]	94
6 [22.7]	141
8 [30.3]	188
10 [37.9]	235
12 [45.4]	282
14 [53.0]	330
15 [56.8]	353

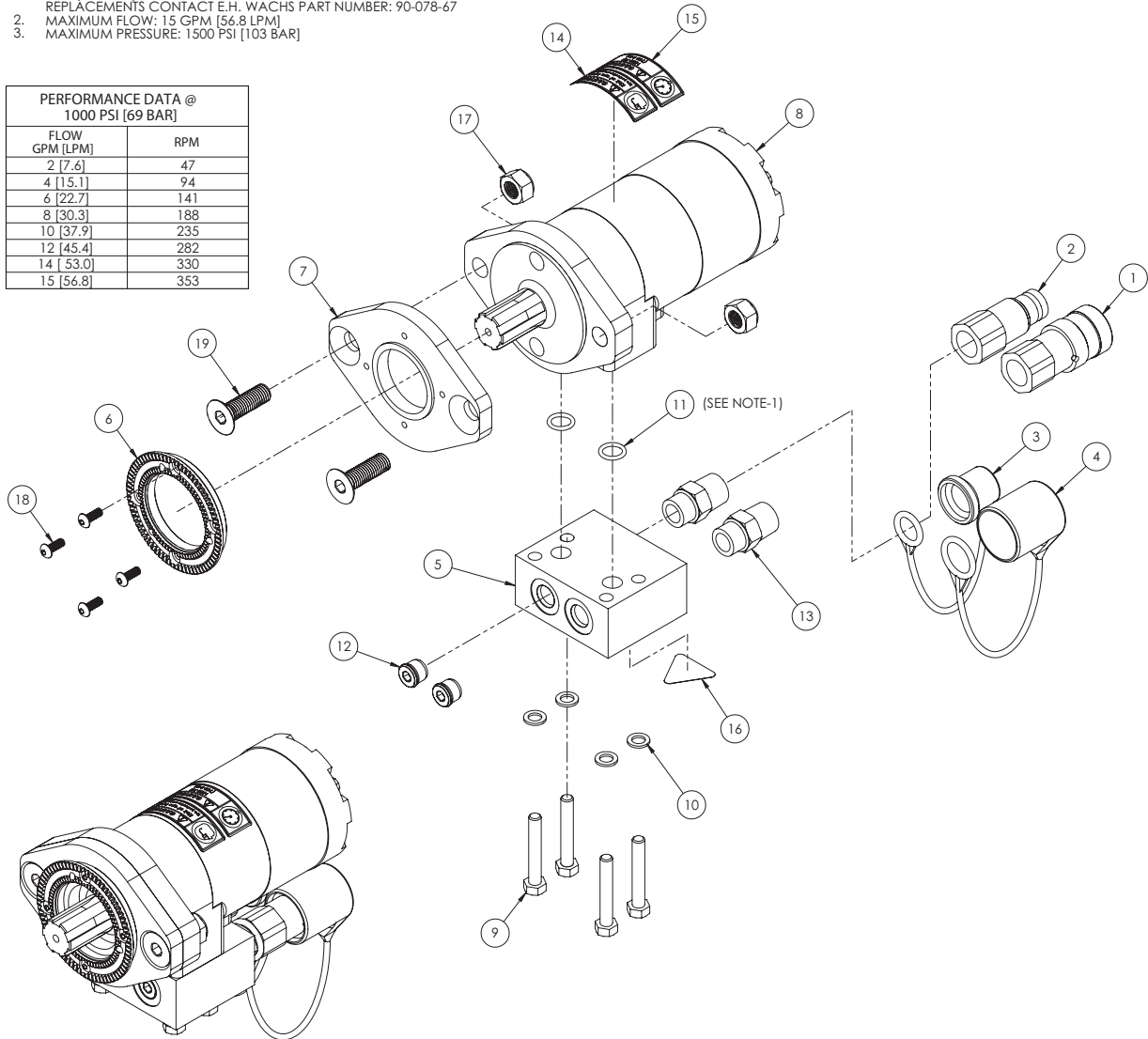

Sous-ensemble collecteur hydraulique, 69-3026-00

ITEM	PART NUMBER	QTY	DESCRIPTION
1	60-198-00	1	VALVE, MRV DIRECTIONAL CONTROL
2	60-199-00	1	MANIFOLD, SDB HYDRAULIC
3	60-1186-00	1	LCSF FLOW DIRECTION LABEL
4	76-072-00	1	PLATE, MRV ANTI-ROTATION
5	76-073-00	1	CAP, MRV OPERATOR
6	76-074-00	1	SPRING, TORSION
7	76-075-00	1	PLATE, SPRING COVER
8	76-175-00	1	RETAINING RING, 43/64
9	76-176-00	1	VALVE, PRESSURE RELIEF
10	76-177-00	1	VALVE, PRESSURE COMPENSATED FLOW CONTROL
11	76-181-00	1	DETENT SPRING
12	76-182-00	1	SPACER
13	76-183-00	1	HANDLE, 5/16"-18
14	76-185-00	1	FLOW CONTROL LABEL
15	90-026-56	1	PIN, 1/8 X 5/8 ROLL
16	90-026-58	2	PIN, 1/8 X 7/8 ROLL
17	90-026-61	2	PIN, 1/8 X 1.125 ROLL
18	90-055-18	1	NUT, 1/4-20 ACORN
19	90-088-84	2	PLUG, -04 ZERO-LEAK ORB
20	90-088-86	8	PLUG, -06 ZERO-LEAK ORB
21	90-098-79	1	ADAPTER, 1/2 NPT M X 1/2 ORB M - STRAIGHT
22	90-098-89	1	ELBOW, 1/2 ORB M X 1/2 NPT M - 90
23	90-401-01	1	LABEL, EYE PROTECTION
24	90-401-04	1	LABEL, CRUSH AND CUT
25	90-403-02	1	LABEL, BURN HAZARD/HOT SURFACE

Rev B

NOTES:
1. SPRING ITEM #6 NEEDS TO BE COMPRESSED BETWEEN PINS ITEM #16.

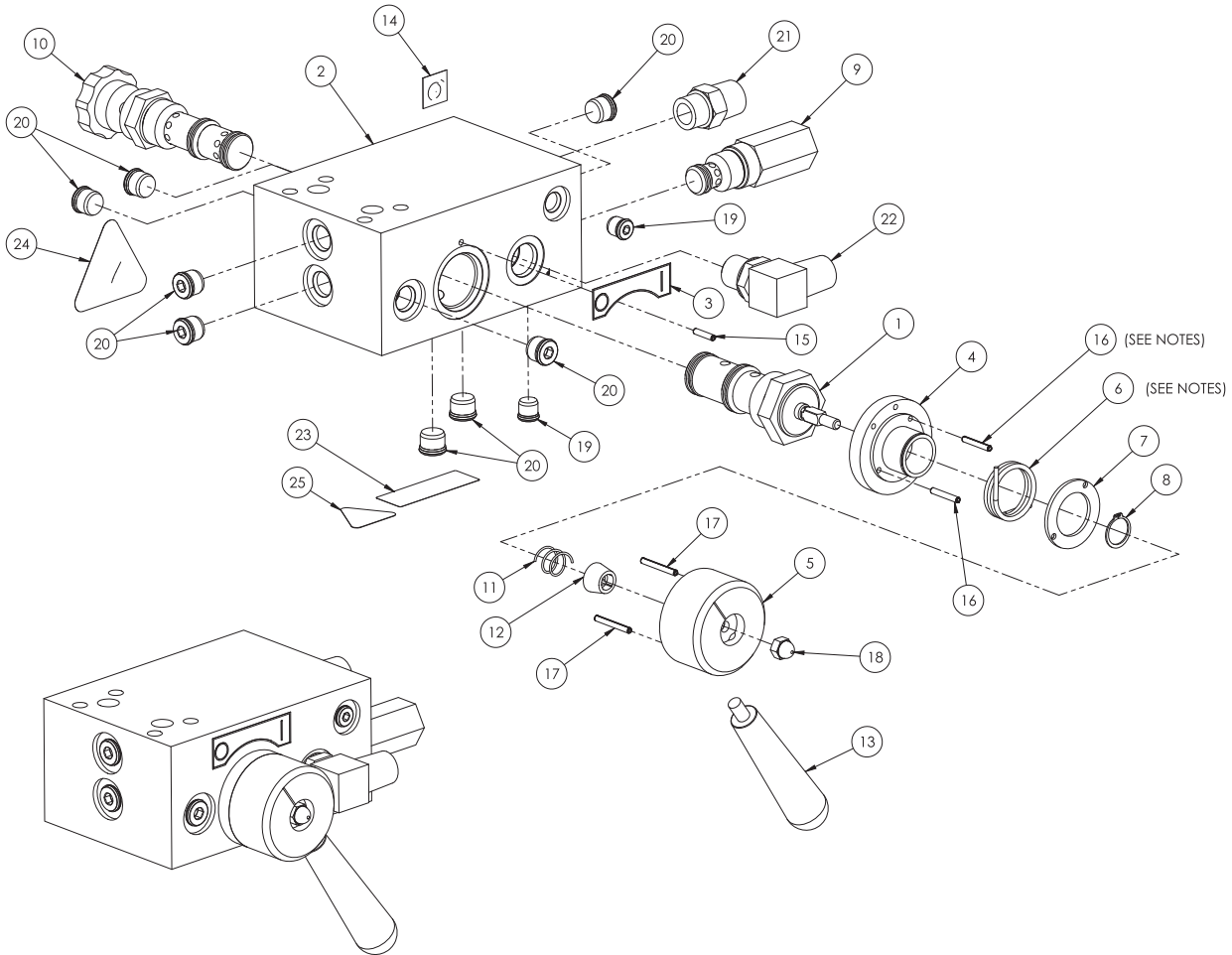

Commande électrique par entraînement (230 V, monophasée), 69-4357-01

ITEM	PART NUMBER	QTY	DESCRIPTION	ORBITALUM PART NUMBER
1	60-1334-00	1	POWER BOX, EPD	900 007 201
2	60-1336-00	1	REMOTE CONTROL, EPD	900 007 301
3	60-1341-00	1	CASE, STORAGE W/INSERT - EPD (NOT SHOWN)	900 007 107
4	60-1343-00	1	CABLE, 220V	900 007 102
5	69-0153-16	1	MOTOR, EPM8-160 MDSF	969 015 316
6	69-3031-00	1	ADAPTER, ELECTRIC DRIVE	969 303 100

Rev A

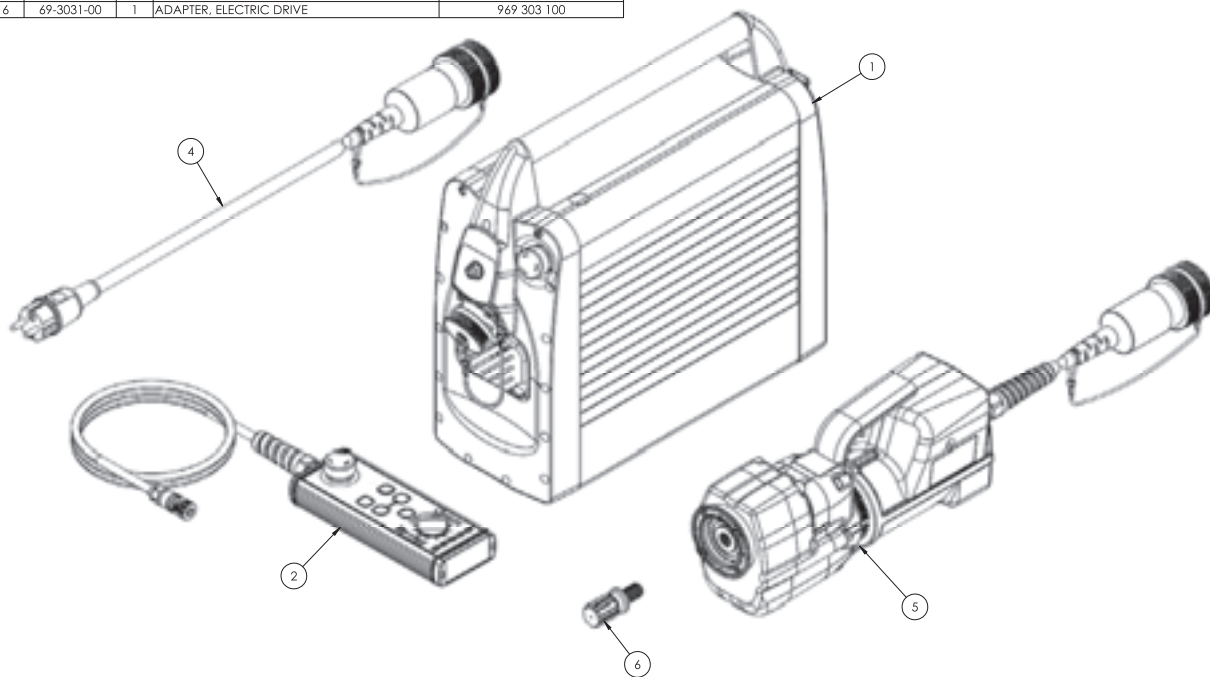

Commande électrique par entraînement (220-480 V, triphasée), 69-4357-03

ITEM	PART NUMBER	QTY	DESCRIPTION	ORBITALUM PART NUMBER
1	60-1334-00	1	POWER BOX, EPD	900 007 201
2	60-1336-00	1	REMOTE CONTROL, EPD	900 007 301
3	60-1338-00	1	CABLE, 380 - 480V	900 007 102
4	60-1341-00	1	CASE, STORAGE W/INSERT - EPD (NOT SHOWN)	900 007 107
5	69-0153-16	1	MOTOR, EPM8-160 MDSF	969 015 316
6	69-3031-00	1	ADAPTER, ELECTRIC DRIVE	969 303 100

Rev A

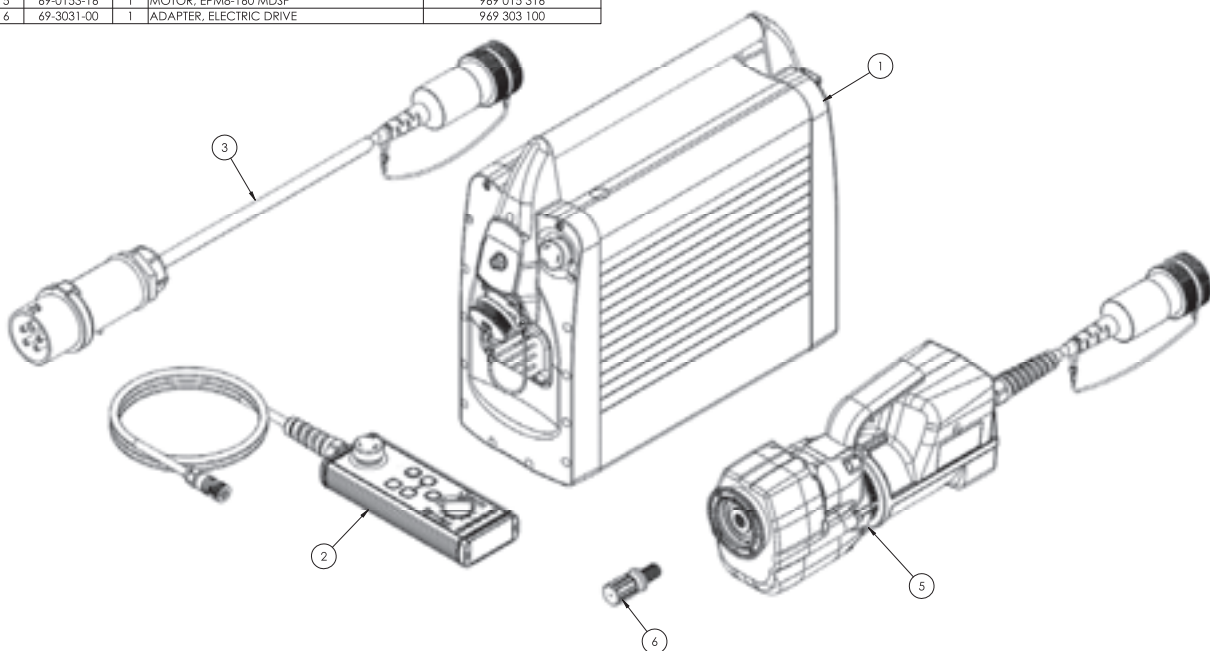

Chapitre 5

Porte-outils et déclencheurs

PLATEAUX STANDARD

Les plateaux DynaPrep standard sont disponibles en six combinaisons, avec trois longueurs différentes de courses et deux vitesses d'alimentation. Les tables suivantes répertorient les ensembles utilisés pour chaque plateau. Les dessins des pages suivantes illustrent l'ensemble de plateaux, avec les références de chaque pièce.

Pour l'entretien, les ensembles sont remplacés par modules.

Tableau 1: Ensemble de plateaux standard

Plateau		Ensemble enfourneuse à vis	Ensemble base du plateau
69-4615-03	Avance de 0,003", course de 1,5"	69-3003-03	69-3004-15
69-4615-06	Avance de 0,006", course de 1,5"	69-3003-06	
69-4625-03	Avance de 0,003", course de 2,5"	69-3005-03	69-3004-25
69-4625-06	Avance de 0,006", course de 2,5"	69-3005-06	
69-4655-03	Avance de 0,003", course de 5,5"	69-3006-03	69-3004-55
69-4655-06	Avance de 0,006", course de 5,5"	69-3006-06	

Tableau 2: Ensemble enfourneuse à vis

Ensemble enfourneuse à vis	Boîtier déclencheur	Ensemble cartouche	Cartouche à visse
69-3003-03	69-0009-00	69-3007-03	69-3008-03
69-3003-06	69-0030-00	69-3007-06	69-3008-06
69-3005-03	69-0009-00	69-3007-03	69-3010-03
69-3005-06	69-0030-00	69-3007-06	69-3010-06
69-3006-03	69-0009-00	69-3007-03	69-3011-03
69-3006-06	69-0030-00	69-3007-06	69-3011-06

Ensemble de plateaux

ITEM	PART NUMBER	QTY	DESCRIPTION
1	69-3001-00	1	TOOL COVER ASSEMBLY
2	69-3002-00	1	TOOL SADDLE ASSEMBLY
3	69-3004-XX	1	SLIDE BASE ASSEMBLY, SEE TABLE 1
4	69-300X-0X	1	WORM FEED ASSEMBLY, SEE TABLE 1

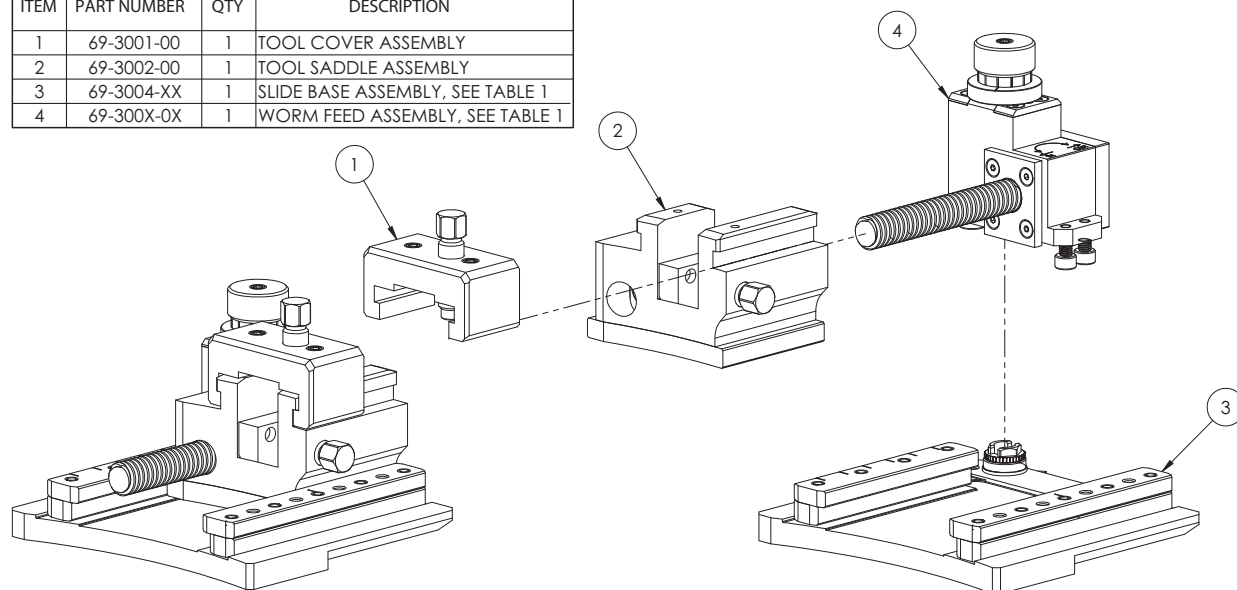

PORTE-OUTILS À LAMER

Porte-outil à lamer 3 po, 69-4605-00

ITEM	PART NUMBER	QTY	DESCRIPTION
1	69-3022-03	1	C'BORE HOUSING ASSEMBLY, 3"
2	69-3023-03	1	C'BORE BAR ASSEMBLY, 3"
3	69-3024-00	1	C'BORE BASE ASSEMBLY

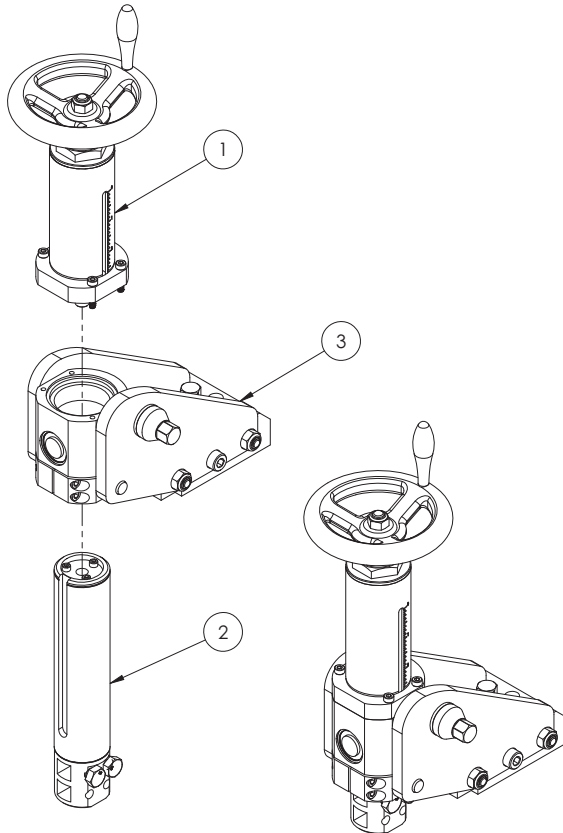

Porte-outil à lamer 6 po, 69-4606-00

ITEM	PART NUMBER	QTY	DESCRIPTION
1	69-3022-06	1	C'BORE HOUSING ASSEMBLY, 6"
2	69-3023-06	1	C'BORE BAR ASSEMBLY, 6"
3	69-3024-00	1	C'BORE BASE ASSEMBLY

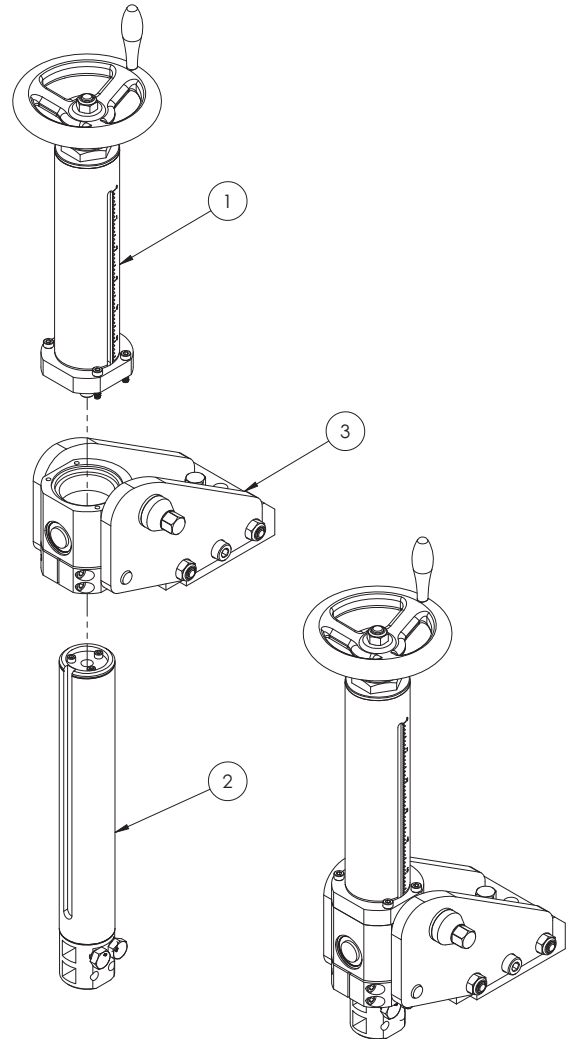

Ensemble embouts de chanfreinage 3 po, 69-3022-03

ITEM	PART NUMBER	QTY	DESCRIPTION
1	69-0101-03	1	TUBE, HOUSING-C'BORE 3"
2	69-0102-00	1	SHAFT, FEED HANDLE
3	69-0103-00	1	HUB
4	69-0104-03	1	SCREW, FEED-C'BORE 3"
5	69-0105-00	1	HAND WHEEL, MODIFIED
6	69-0106-00	1	PLATE, TUBE RETAINING
7	69-8028-00	2	BEARING, 5/8" ID THRUST
8	69-8029-00	1	WASHER, 11/16" WAVE
9	69-8030-00	1	BUSHING, 5/8" X 3/4" X 1/2" LG.
10	69-8031-00	4	THRUST WASHER
11	69-8032-00	1	RING, 1.750 X .068 EXTERNAL RETAINING
12	90-019-43	1	KEY, 3/32 X 3/8 WOODRUFF
13	90-1016-00	1	NUT, M8 NYLOCK
14	90-1022-20	1	PIN, 3.5MM X 20MM ROLL
15	90-1023-20	4	SHCS, M4 X 0.7MM X 20MM SS18-8

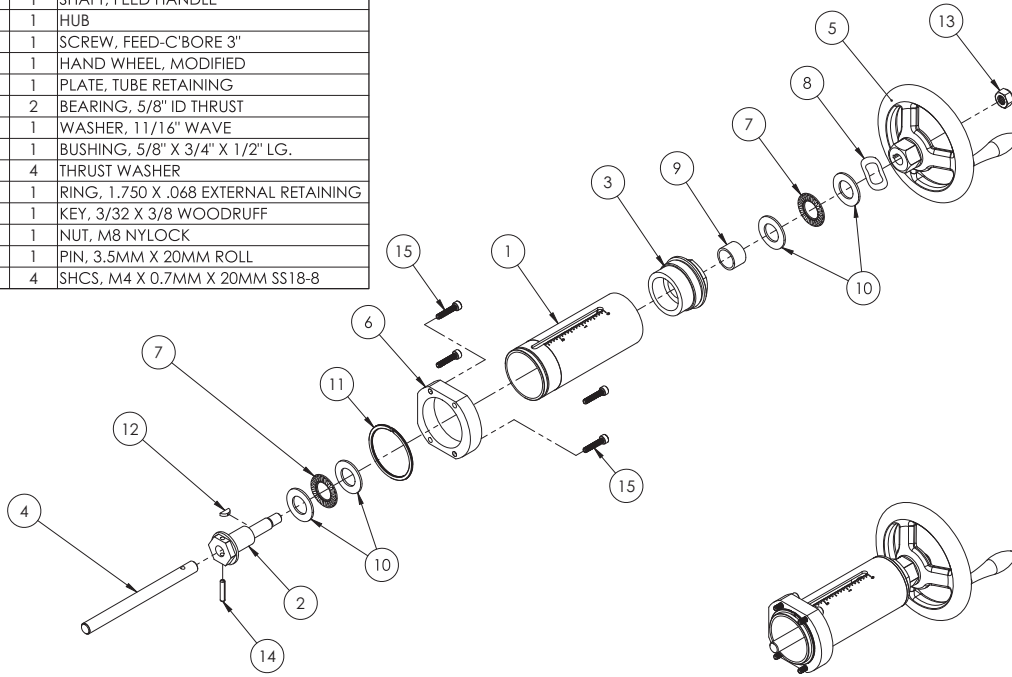

Ensemble embouts de chanfreinage 6 po, 69-3022-06

ITEM	PART NUMBER	QTY	DESCRIPTION
1	69-0101-06	1	TUBE, HOUSING-C'BORE 6"
2	69-0102-00	1	SHAFT, FEED HANDLE
3	69-0103-00	1	HUB
4	69-0104-06	1	SCREW, FEED-C'BORE 6"
5	69-0105-00	1	HAND WHEEL, MODIFIED
6	69-0106-00	1	PLATE, TUBE RETAINING
7	69-8028-00	2	BEARING, 5/8" ID THRUST
8	69-8029-00	1	WASHER, 11/16" WAVE
9	69-8030-00	1	BUSHING, 5/8" X 3/4" X 1/2" LG.
10	69-8031-00	4	THRUST WASHER
11	69-8032-00	1	RING, 1.750 X .068 EXTERNAL RETAINING
12	90-019-43	1	KEY, 3/32 X 3/8 WOODRUFF
13	90-1016-00	1	NUT, M8 NYLOCK
14	90-1022-20	1	PIN, 3.5MM X 20MM ROLL
15	90-1023-20	4	SHCS, M4 X 0.7MM X 20MM SS18-8

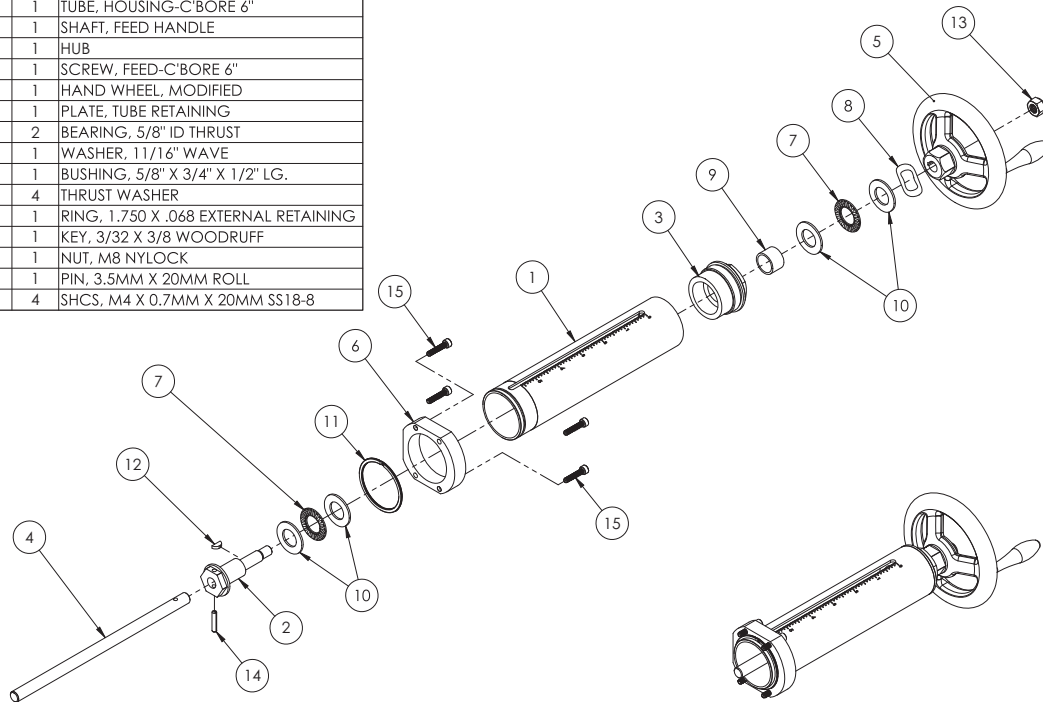

Ensemble barre de chanfreinage 3 po, 69-3023-03

ITEM	PART NUMBER	QTY	DESCRIPTION
1	69-0099-03	1	BAR, C'BORE 3"
2	69-0100-00	1	NUT, FEED
3	90-1002-12	2	HHCS, M8 X 1.25MM X 12MM
4	90-1021-12	3	SHCS, M3.5 X 0.6MM X 12MM

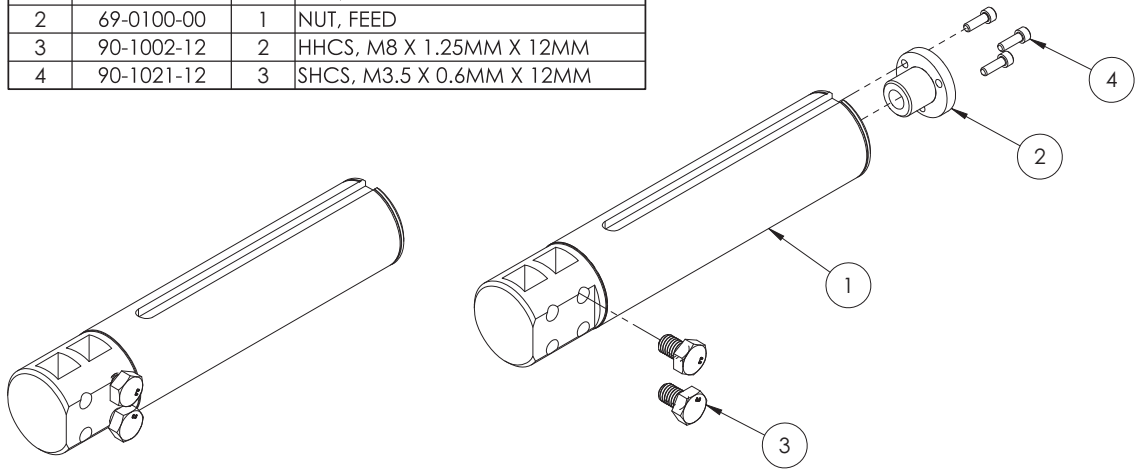

Ensemble barre de chanfreinage 6 po, 69-3023-06

ITEM	PART NUMBER	QTY	DESCRIPTION
1	69-0099-06	1	BAR, C'BORE 6"
2	69-0100-00	1	NUT, FEED
3	90-1002-12	2	HHCS, M8 X 1.25MM X 12MM
4	90-1021-12	3	SHCS, M3.5 X 0.6MM X 12MM

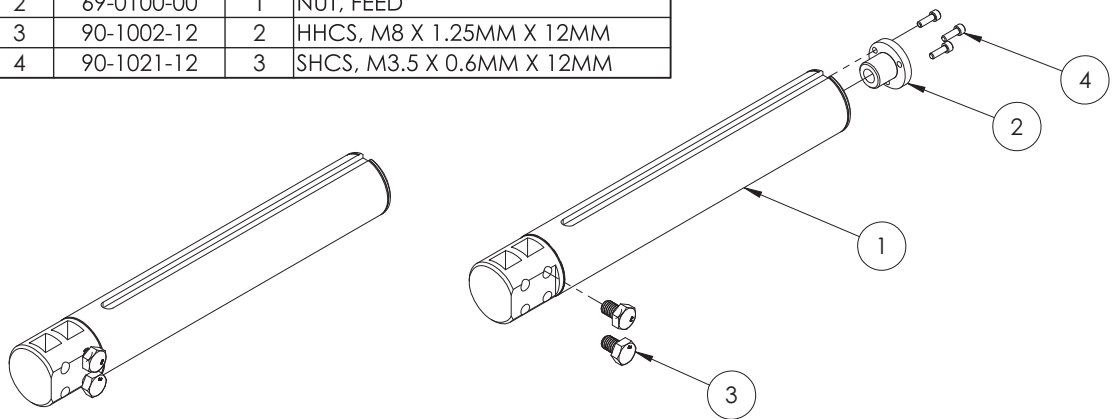

Ensemble base de chanfreinage, 60-434-00

ITEM	PART NUMBER	QTY	DESCRIPTION
1	69-0002-00	2	SCREW, TOP LOCK
2	69-0107-00	1	KEY, BORING BAR
3	69-0108-00	1	HOUSING, PIVOT
4	69-0109-00	1	PLATE, PIVOT SLIDE-LEFT
5	69-0110-00	1	BLOCK, PIVOT SLIDE-LOCKING
6	69-0111-00	1	BLOCK, PIVOT SLIDE-MOUNTING
7	69-0112-00	1	NUT, PIVOT
8	69-0113-00	1	PLATE, PIVOT SLIDE-RIGHT
9	69-8033-00	1	SPRING, 6MM WAVE
10	69-8034-00	1	RING .987 X .037 INTERNAL RETAINING
11	90-1001-22	2	SHCS, M5 X 0.8MM X 22MM
12	90-1003-08	1	PIN, 6MM X 8MM DOWEL
13	90-1010-20	1	SHCS, M8 X 1.25MM X 20MM
14	90-1012-01	1	WASHER, M12 FLAT
15	90-1014-20	2	PIN, 10MM X 20MM DOWEL
16	90-1016-00	2	NUT, M8 NYLOCK
17	90-1024-90	1	HHCS, M10 X 1.5MM X 90MM
18	90-1025-10	1	SSS, M5 X 0.8MM X 10MM FLAT SS18-8
19	90-1026-70	2	SHSB, 10MM X 70MM

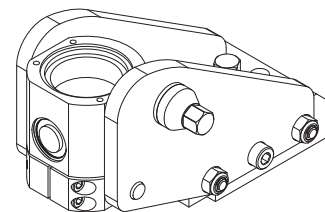
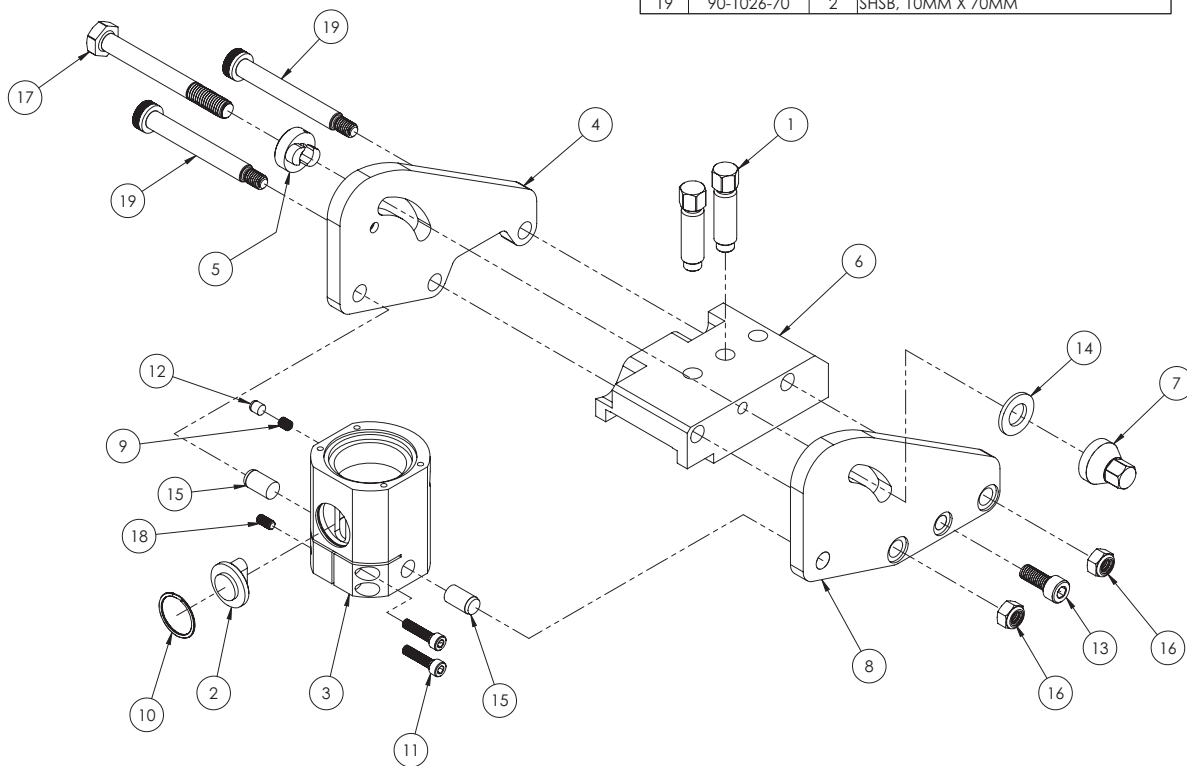

DIAMÈTRE EXTÉRIEUR SUIVEURS DE PROFIL

DIAMÈTRE EXTÉRIEUR Suiveur de profil, 69-4604-01

ITEM	PART NUMBER	QTY	DESCRIPTION
1	60-1042	2	SPRING, 1.795 X 1.271 X 6.0 LG.
2	69-0006-01	1	BLOCK, .67 TOOL SUPPORT
3	69-0006-02	1	BLOCK, .75 TOOL SUPPORT (NOT SHOWN)
4	69-0006-03	1	BLOCK, 1.00 X .92 TOOL SUPPORT (NOT SHOWN)
5	69-0165-01	1	PLATE, BASE-O.D. TRACKING
6	69-0166-01	1	MOUNT, RIGHT GUIDE BAR-O.D. TRACKING
7	69-0167-01	1	MOUNT, LEFT GUIDE BAR-O.D. TRACKING
8	69-0168-01	1	PLATE, GUIDE BAR SUPPORT-O.D. TRACKING
9	69-0169-00	2	ROD, STIFFENER-O.D. TRACKING
10	69-0170-01	2	SHAFT, GUIDE-O.D. TRACKING
11	69-0171-00	2	RETAINER, SPRING-O.D. TRACKING
12	69-0172-00	2	BEARING, 1.002 X 1.259 X 1.0 LG. SLEEVE
13	69-0173-00	1	RETAINER, STARWHEEL-O.D. TRACKING
14	69-0174-01	1	SCREW, FEED-O.D. TRACKING
15	69-0175-00	1	PLATE, TRACKING BAR END
16	69-0176-01	1	SCREW, SPRING TENSIONING-O.D. TRACKING
17	69-0177-00	1	BUSHING, FEED SCREW-O.D. TRACKING
18	69-0178-00	1	STARWHEEL O.D. TRACKING
19	69-3001-00	1	TOOL COVER ASSEMBLY
20	69-3035-00	1	TOOL HOLDER ASSEMBLY, O.D. TRACKING
21	69-3036-01	1	SLIDE SUB-ASSEMBLY, O.D. TRACKING
22	69-8040-00	2	SNAP RING, ROUND 1" SHAFT X .085 DIAMETER
23	69-8041-00	1	BEARING, 15MM X 28MM X 2MM THRUST
24	69-8042-00	1	BEARING, 1/2" X 15/16" X 5/64" THRUST
25	69-8043-00	2	WASHER, 1/2" X 15/16" X 1/32" THRUST
26	69-8044-00	2	WASHER, 15MM X 28MM X 1MM THRUST
27	69-8045-00	1	WASHER, 1/2" TRIPLE WAVE
28	69-8046-00	1	RING, RETAINING, 1.197 X .056 INT.
29	90-019-43	1	KEY, 3/32 X 3/8 WOODRUFF
30	90-054-38	1	ISS, 1/4-28 X 3/8 CUP PT. (NOT SHOWN/SHIPPED LOOSE)
31	90-300-05	1	ZERR, 1/4-28 UNF STR (NOT SHOWN/SHIPPED LOOSE)
32	90-1001-14	6	SHCS, M5 X 0.8MM X 14MM
33	90-1004-14	12	SHCS, M6 X 1MM X 14MM
34	90-1004-18	4	SHCS, M6 X 1MM X 18MM
35	90-1004-18	4	SHCS, M6 X 1MM X 18MM
36	90-1030-10	2	PIN, 4MM X 10MM DOWEL
37	90-1035-22	2	SHCS, M10 X 1.5MM X 22MM
38	90-1036-08	1	PIN, 3MM X 8MM DOWEL
39	90-1037-14	2	PIN, 5MM X 14MM DOWEL

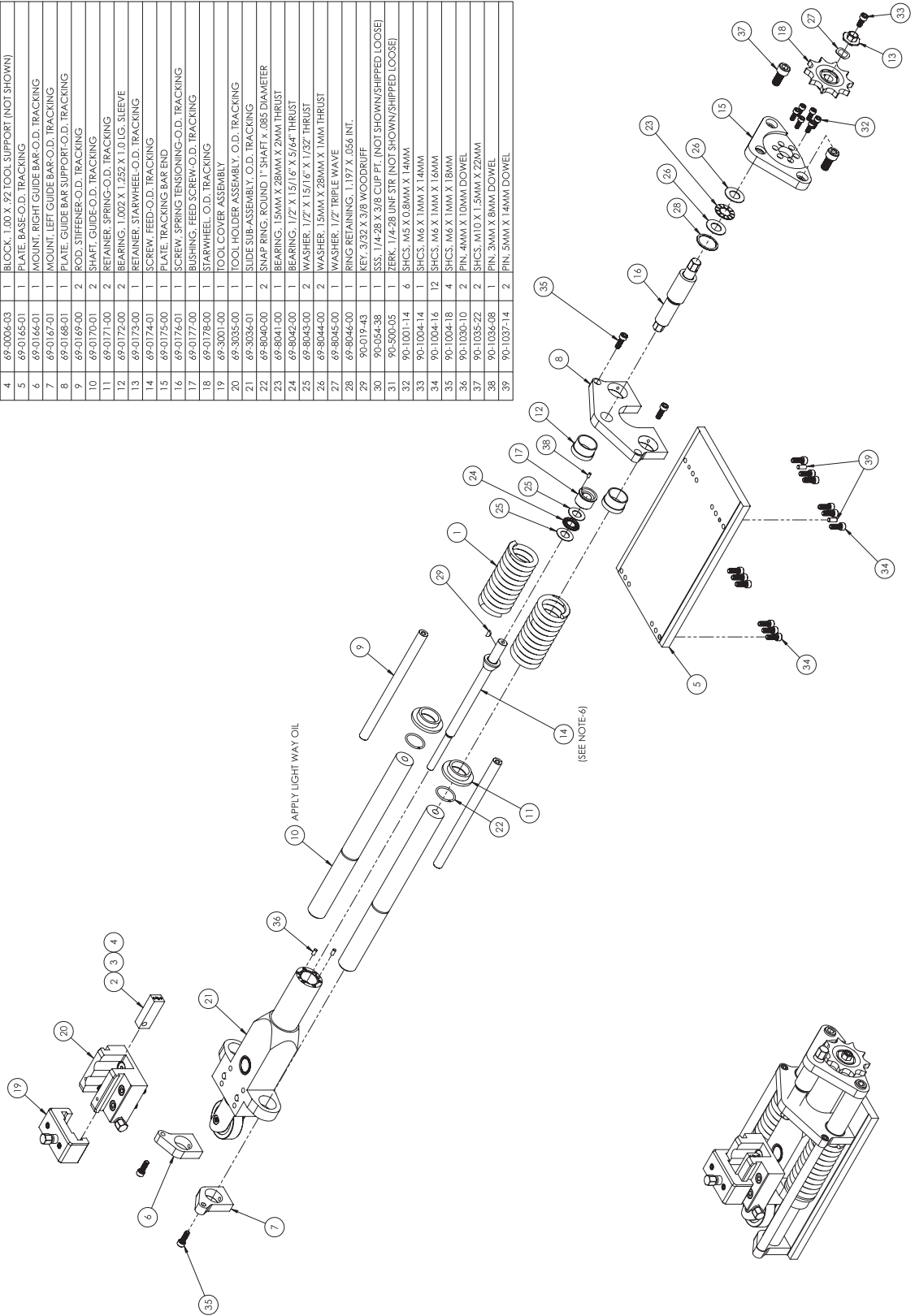

DIAMÈTRE EXTÉRIEUR Sous-ensemble suiveurs de profil, 69-3036-01

ITEM	PART NUMBER	QTY	DESCRIPTION
1	60-1256-00	1	RETAINING RING, EXTERNAL
2	69-0160-00	1	SLIDE, FEMALE-O.D. TRACKING
3	69-0161-01	1	BAR, SLIDE-O.D. TRACKING
4	69-0162-00	1	PIN, SLIDE COUPLING-O.D. TRACKING
5	69-0163-00	1	SPOOL, FOLLOWER-O.D. TRACKING
6	69-0164-00	1	PIN, FOLLOWER-O.D. TRACKING
7	69-8039-00	1	TRACK ROLLER, LR5005-2RS
8	90-054-38	1	SSS, 1/4-28 X 3/8"
9	90-1033-18	2	PIN, 8MM X 18MM DOWEL
10	90-1034-12	1	SSS, M5 X 0.8MM X 12MM DP

REV A

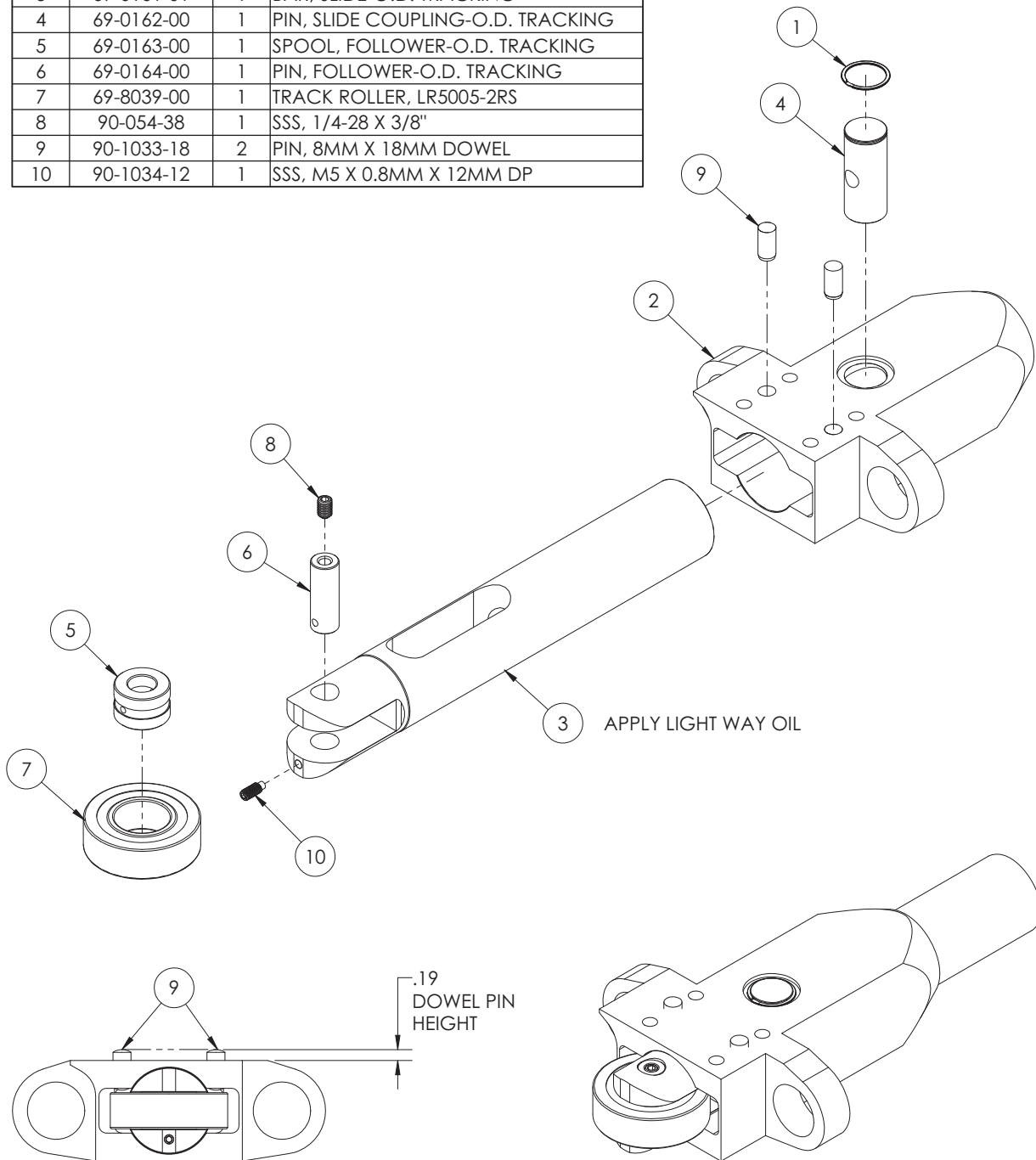

DIAMÈTRE EXTÉRIEUR Ensemble porte-outils de suiveurs de profil, 69-3035-00

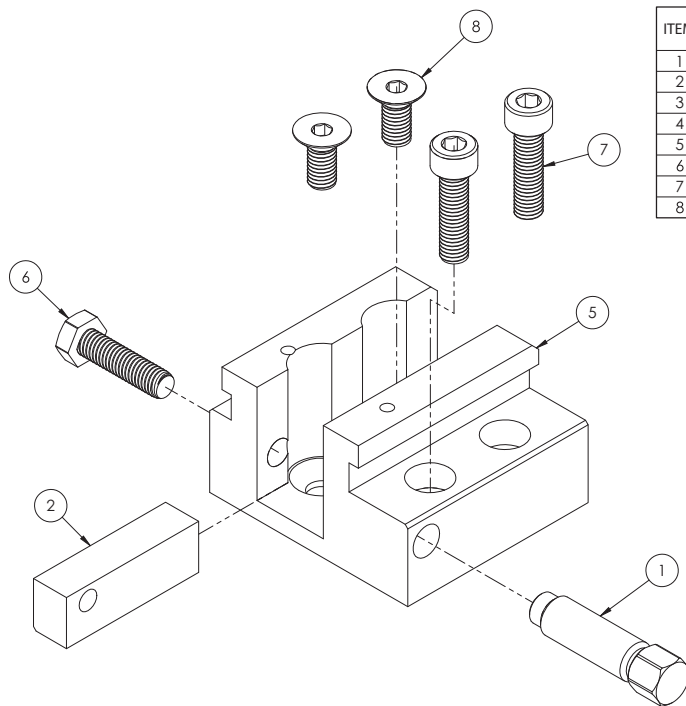

ITEM	PART NUMBER	QTY	DESCRIPTION
1	69-0002-00	1	SCREW, TOP LOCK
2	69-0006-01	1	BLOCK, .67 TOOL SUPPORT
3	69-0006-02	1	BLOCK, .75 TOOL SUPPORT (NOT SHOWN)
4	69-0006-03	1	BLOCK, 1.00 X .92 TOOL SUPPORT (NOT SHOWN)
5	69-0159-00	1	HOLDER, TOOL-O.D. TRACKING
6	90-1002-30	1	HHCS, M8 X 1.25MM X 30MM
7	90-1010-30	2	SHCS, M8 X 1.25MM X 30MM
8	90-1032-18	2	FHCS, M8 X 1.25MM X 18MM

KIT D'ADAPTATEUR POUR TRAVERSE, 69-5300-00

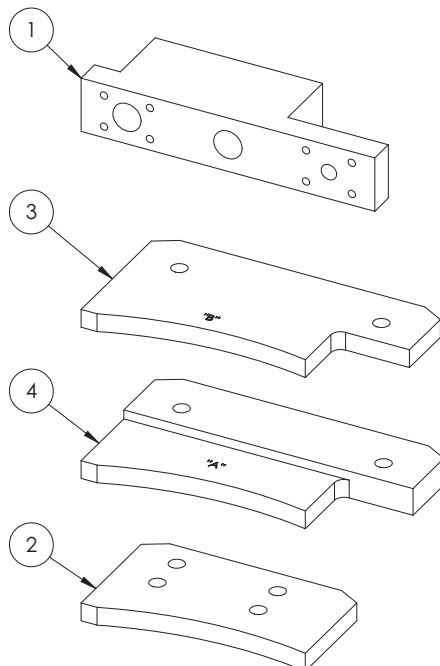

ITEM	PART NUMBER	QTY	DESCRIPTION
1	69-0199-00	1	SUPPORT, BOTTOM
2	69-0200-00	1	SUBPLATE, BRIDGE SLIDE BOTTOM
3	69-0201-00	1	SUBPLATE, 24" BRIDGE SLIDE TOP
4	69-0202-00	1	SUBPLATE, BRIDGE SLIDE TOP "A"
5	69-3046-00	1	DUAL TRIP ASSEMBLY

ENSEMBLES DE DÉCLENCHEMENT

Déclencheur manuel, 69-3018-00

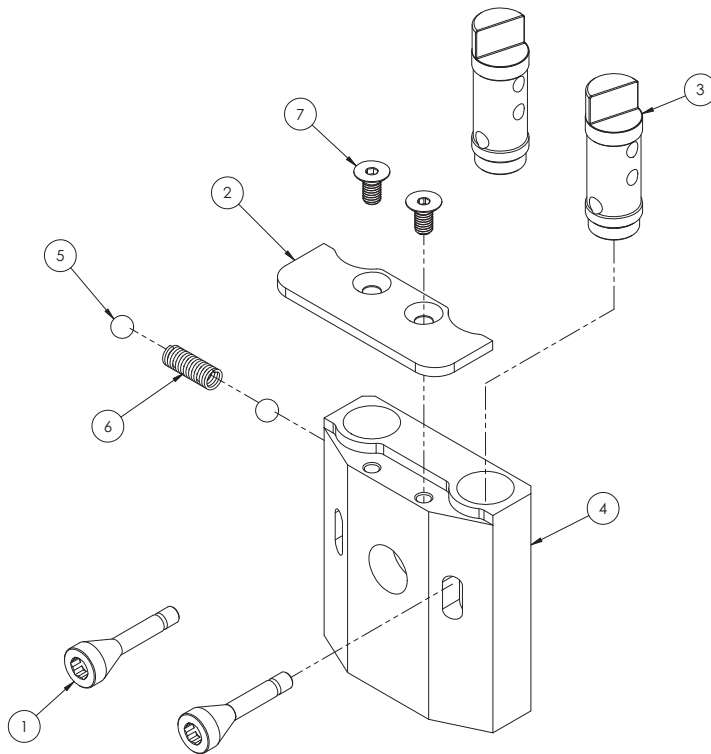

ITEM	PART NUMBER	QTY	DESCRIPTION
1	69-0067-00	2	KNOB, PIN
2	69-0068-00	1	GUARD, TRIP
3	69-0069-00	2	PIN, TRIP
4	69-0070-00	1	BLOCK, TRIP
5	69-8000-00	2	BALL, 1/4" DIA. CHROME
6	69-8016-00	1	SPRING, .25 OD X 1.00 LG X .029 WIRE
7	90-1009-10	2	FHCS, M5 X 0.8MM X 10MM

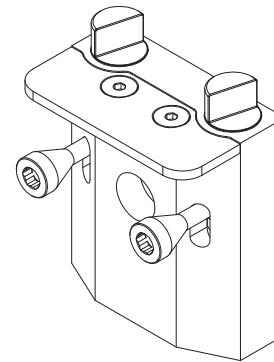

Déclencheur pneumatique avec commande à distance, 69-4741-00

ITEM	PART NUMBER	QTY	DESCRIPTION
1	69-3045-00	1	TRIP REMOTE CONTROL, PNEUMATIC
2	69-3047-00	1	TRIP ASSEMBLY-PNEUMATIC

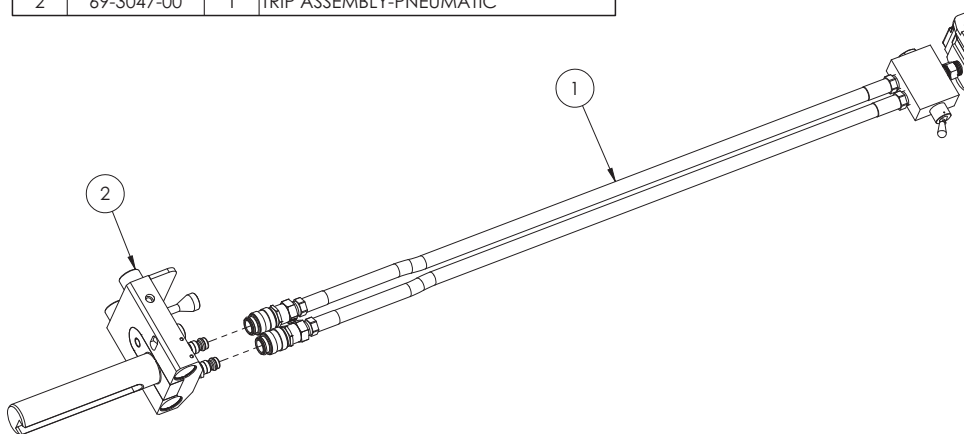

Déclencheur pneumatique avec commande à distance, 69-4741-00

ITEM	PART NUMBER	QTY	DESCRIPTION
1	69-8058-00	2	AIR HOSE, 1/8 NPTF X 10-FT. LONG
2	69-8059-00	1	PRESSURE REGULATOR, SMC
3	69-8060-00	1	SWITCH, TOGGLE
4	90-004-01	1	NIPPLE, 1/8 HEX
5	90-078-22	1	COUPLING, 1/8" MALE x 1/8" NPT (M)
6	90-078-23	2	QD COUPLING, 1/8" (F) X 1/8" NPT (F)

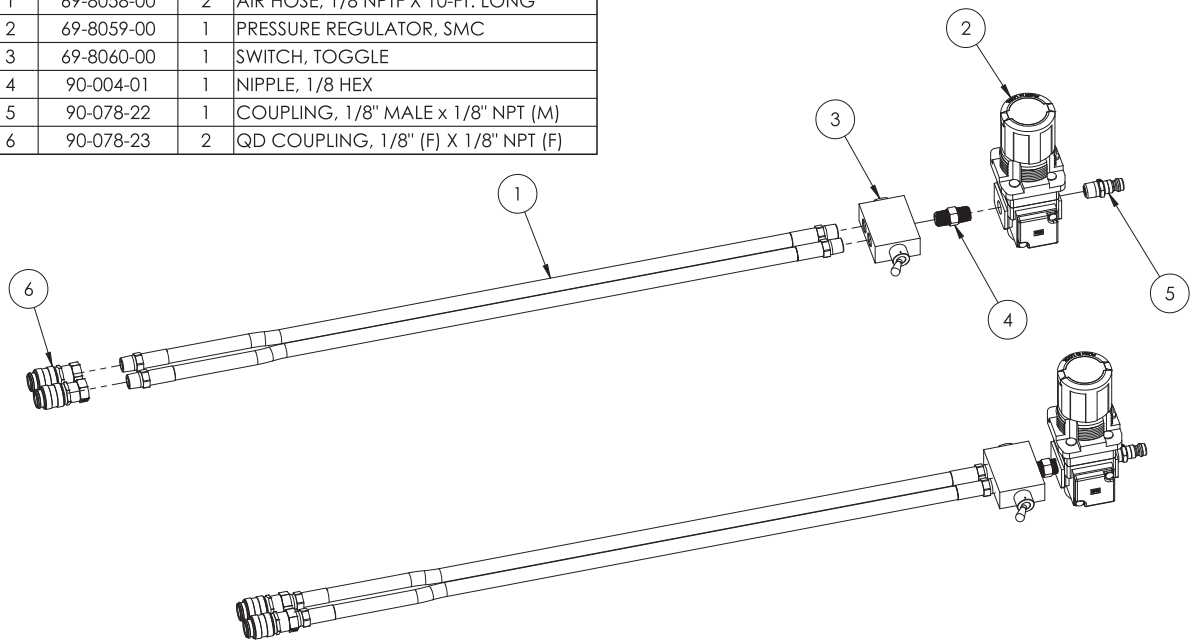

Ensemble déclencheur pneumatique, 60-434-00

ITEM	PART NUMBER	QTY	DESCRIPTION
1	69-0071-00	1	BAR, TRIP POSITIONING
2	69-3020-00	1	TRIP, PNEUMATIC OPERATION
3	90-1010-16	1	SHCS, M8 X 1.25MM X 16MM

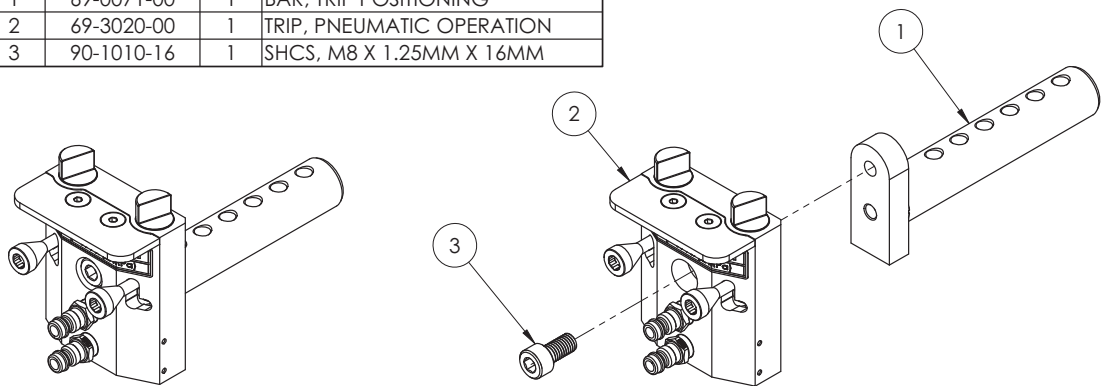

Déclencheur pneumatique, 69-3020-00

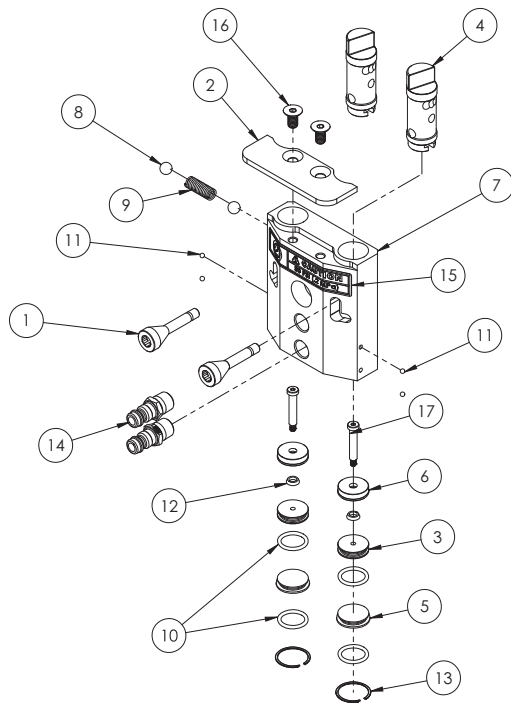

ITEM	PART NUMBER	QTY	DESCRIPTION
1	69-0067-00	2	KNOB, PIN
2	69-0068-00	1	GUARD, TRIP
3	69-0074-00	2	PISTON, PNEUMATIC TRIP
4	69-0075-00	2	PIN, PNEUMATIC TRIP
5	69-0076-00	2	CAP, CYLINDER PNEUMATIC TRIP
6	69-0077-00	2	HEAD, CYLINDER PNEUMATIC TRIP
7	69-0078-00	1	BLOCK, PNEUMATIC TRIP
8	69-8000-00	2	BALL, 1/4" DIA. CHROME
9	69-8016-00	1	SPRING, .25 OD X 1.00 LG X .029 WIRE
10	69-8017-00	4	O-RING, (-014) BUNA-N
11	69-8018-00	4	BALL, 3/32" DIA. CHROME
12	69-8019-00	2	SEAL, U-CUP 5/32" ID x 9/32" OD x 1/16" HT.
13	69-8020-00	2	RING, RETAINING
14	90-078-22	2	COUPLING, 1/8" MALE x 1/8" NPT (M)
15	90-407-00	1	LABEL, PRESSURE-AIR (MPa)
16	90-1009-10	2	FHCS, M5 X 0.8MM X 10MM
17	90-1011-20	2	SHSB, 4MM X 20MM SS18-8

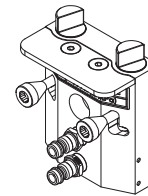

Ensemble déclencheur double, 69-3046-00

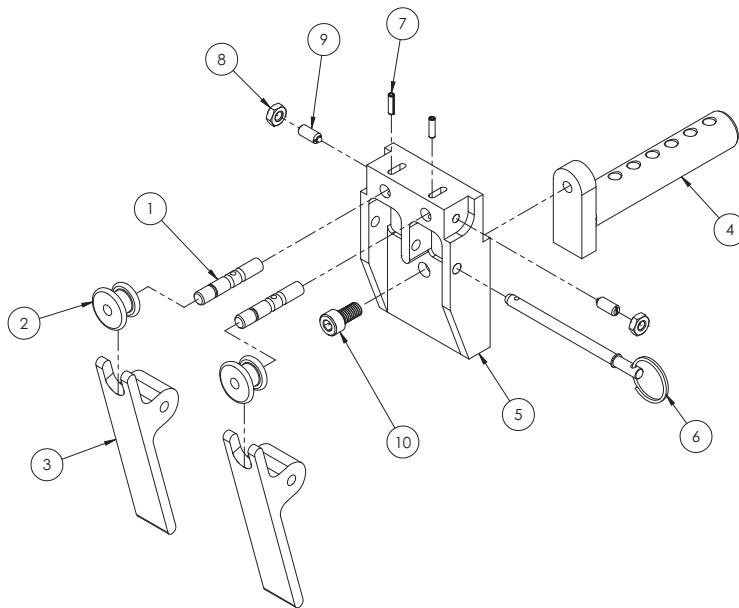

ITEM	PART NUMBER	QTY	DESCRIPTION
1	60-338-00	2	PIN, TRIP
2	60-1048-00	2	SPOOL
3	60-1049-00	2	LEVER
4	69-0071-00	1	BAR, TRIP POSITIONING
5	69-0203-00	1	BLOCK, DUAL TRIP PIN HOUSING
6	69-8057-00	1	QUICK PIN
7	90-026-55	2	1/8" X 1/2" PIN
8	90-055-04	2	NUT, 1/4-20 JAM
9	90-059-08	2	SPRING PLUNGER
10	90-1010-16	1	SHCS, M8 X 1.25MM X 16MM

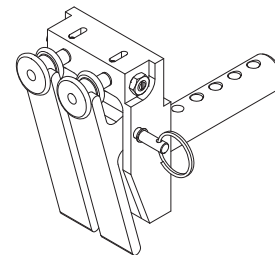

Ensemble déclencheur monté sur ressort pour diamètre extérieur Suiveurs de profil, 69-4744-01

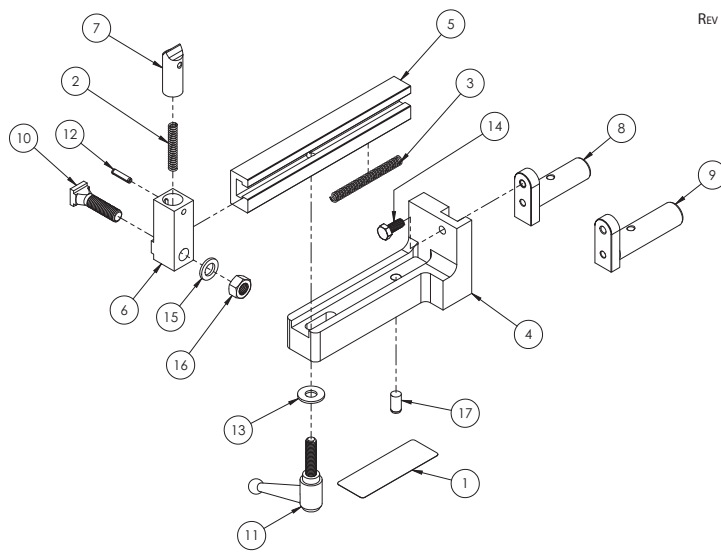

REV A

ITEM	PART NUMBER	QTY	DESCRIPTION
1	03-113-04	1	LABEL, WARNING-MOVING PARTS
2	60-1044	1	SPRING, .329 X .211 X 2.0 LG.
3	60-1225-00	1	SPRING, SLIDE
4	69-0079-00	1	BLOCK, TRIP MOUNTING
5	69-0080-01	1	SLIDE, TRIP
6	69-0081-00	1	HOUSING, FEED PIN
7	69-0082-00	1	FEED, TRIP
8	69-0083-00	1	BAR, TRIP POSITIONING 12"- 24"
9	69-0239-00	1	BAR, O.D. TRACKING TRIP 28"-60"
10	69-8021-00	1	BOLT, T-SLOT M12 X 50MM LG.
11	69-8056-00	1	HANDLE, ADJUSTABLE M10
12	90-146-08	1	PIN, 3/16 X 7/8 ROLL, SS
13	90-175-51	1	WASHER, 3/8 FLAT SS18-8
14	90-1002-20	1	HHCS, M8 X 1.25MM X 20MM
15	90-1012-00	1	WASHER, M12 FLAT-EXTRA THICK SS18-8
16	90-1013-00	1	NUT, M12 HEX SS18-8
17	90-1014-22	1	PIN, 10MM X 22MM DOWEL

