

| | |
|--|--|
|  | PIPE & VALVE |
| | MAINTENANCE MACHINERY |
| Mod. RS-2 S/N: | <input type="text"/> <input type="text"/> <input type="text"/> <input type="text"/> <input type="text"/> <input type="text"/> <input type="text"/> |
| E.H. Wachs Water Utility Products 600 Knightsbridge Parkway, Lincolnshire, IL 60069 | |

PART NUMBER: 78-MAN-01

REVISION NO: R1_1

Revised:
Jan. 2004

RS-2

TABLE OF CONTENTS

| | | |
|--------------------|------------------------------------|-------|
| SECTION I | INTRODUCTION & SPECIFICATIONS..... | 3-4 |
| SECTION II | SAFETY INSTRUCTIONS..... | 5 |
| SECTION III | SET UP & OPERATING PROCEDURES..... | 6-16 |
| SECTION IV | CHARTS & SCHEMATICS..... | 17-19 |
| | Electric RS-2..... | 19 |
| | Hydraulic RS-2..... | 19 |
| | Pneumatic RS-2..... | 19 |
| SECTION V | BILL OF MATERIALS..... | 20-33 |
| | Main Head Assembly..... | 21-22 |
| | Revolution Counter Assembly..... | 21-22 |
| | Hydraulic Drive Assembly..... | 21-22 |
| | Pneumatic Drive Assembly..... | 23-24 |
| | Electric Drive Assembly..... | 25-26 |
| | ACCESSORIES..... | 27-30 |
| | Universal Handwheel..... | 27-28 |
| | 1" Inch Drive Adapter..... | 27-28 |
| | Handwheel Adaptor Plate..... | 27-28 |
| | General Accessories..... | 29-30 |
| | Cleco Air Motor..... | 31-33 |
| SECTION VI | ORDERING INFORMATION..... | 34 |

RS-2

SECTION I INTRODUCTION-SPECIFICATIONS

INTRODUCTION:

The **RS-2** Portable Valve Operator for rising and non-rising stem valves offers reliable opening and closing of water, wastewater, pipeline and petroleum valves.

The RS-2 offers these advantages:

- Available in Hydraulic, Pneumatic or Electric Drive.
- Operate all Rising & Non-Rising Stem valves. From 6" to 60".
- 4" Opening for operating Rising Stem Valves.
- Mount to any Hand Wheel with "Universal Hand Wheel Adapter".
- Forward and Reverse operation.
- Variable Speed Control.
- Built in easy view LCD counter.



**OPERATE YOUR RS-2 AND OTHER
VALVE TURNING AND PIPE
CUTTING EQUIPMENT WITH....**

WACHS

HYDRAULIC POWER UNITS

- Cart Mounted / Electric Start
- 9 to 15 H.P. Gas or Diesel Engines
- 8 to 15 G.P.M. units Available



RS-2

SECTION I

INTRODUCTION-SPECIFICATIONS

SPECIFICATIONS

| | | | |
|--|--|---|--|
| <p><u>CAPACITY:</u></p> <p><u>DRIVE:</u></p> <p><u>DRIVE HUB:</u></p> <p><u>REVOLUTION COUNTER:</u></p> <p><u>FINISH:</u></p> <p><u>DIMENSIONS:</u></p> <p><u>WEIGHT:</u></p> | <p>Operate all rising and non-rising stem valves from 6" to 60", which require mechanized turning.</p> <ul style="list-style-type: none"> • Lightweight Aluminum gear box. • Planetary motor drive. • Two stage reduction. • Steel Ring and Pinion secondary drive. <p>4" opening for rising stem valve operation.</p> <p>Built in "easy view" LCD Counter. Push button reset counts 1/10 revolution increments, forward and reverse automatically.</p> <p>Aluminum gear housing, Zinc plated handle.</p> <p>42" length, 4.75" width, 10.3" height</p> <p>40-45 lbs.</p> | | |
| <u>POWER REQUIREMENTS:</u> | AIR | ELECTRIC | HYDRAULIC |
| | Air drive, 60 cfm @ 90 psi. | Electric, 110 volt AC (15 amps or 3500 watt generator) | Hydraulic, 8 gpm @ 1800 psi |
| <u>MOTOR CONTROLS:</u> | Adjustable speed. Forward and reverse dial. | 2 Speed gear box Forward and reverse control knob. | Variable speed. Adjustable torque control. Forward and reverse control valve |
| <u>OPTIONAL ACCESSORIES:</u> | <ul style="list-style-type: none"> • Universal Handwheel Adaptor (pn: 09-405-00) • 1" Square drive adopter (pn: 09-402-00) • Dedicated Handwheel Adapter Plate (pn: 09-404-00) • 8 ft. Valve Key (pn: 05-402-00) | | |

***NOTE: SEE PAGE 19 FOR PEAK TORQUE AND MAXIMUM RPM OUTPUT**

RS-2

SECTION II

SAFETY INSTRUCTIONS



Read the Following thoroughly before proceeding

Since 1883, EH Wachs has built a reputation for quality and a commitment to consumer satisfaction. In accordance with this, Wachs must take on the added responsibility of doing our best to assure the safest use of our equipment.

We have assembled a list of safety reminders to aid in creating the safest possible working environment. We recommend that the precautionary steps listed there be closely observed.

1. **READ THE OPERATING MANUAL!!**

Reading the setup and operating instructions prior to beginning the setup procedures can save valuable time and help prevent injury to operators or damage to machines.

2. **INSPECT MACHINE & ACCESSORIES!**

Prior to machine setup physically inspect the machine and it's accessories. Look for worn tool slides, loose bolts or nuts, lubricant leakage, excessive rust, etc. A properly maintained machine can greatly decrease the chances for injury.

3. **ALWAYS READ PLACARDS & LABELS!**

All placards, labels and stickers must be clearly legible and in good condition. Replacement labels can be purchased from the manufacturer.

4. **KEEP CLEAR OF ROTATING PARTS!**

Keep hands, arms and fingers clear of all rotating or moving parts. Always turn machine off before attempting any adjustments requiring contact with the machine or it's accessories.

5. **SECURE LOOSE CLOTHING & JEWELRY!**

Loose fitting clothing, jewelry; long, unbound hair can get caught in the rotating parts on machines. By keeping these things secure or removing them you can greatly reduce the chance for injury.

6. **KEEP WORK AREA CLEAR!**

Be sure to keep the work area free of clutter and nonessential materials. Only allow those personnel directly associated with the work being performed to have access to the area if possible.

ALWAYS WEAR PROTECTIVE EQUIPMENT:

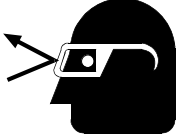
| | |
|--|---|
|  | WARNING Impact resistant eye protection must be worn while operating or working near this tool. |
|--|---|

For additional information on eye and face protection, refer to federal OSHA regulations, 29 Code of Federal Regulations, Section 1019.133., Eye and Face Protection and American National Standards Institute, ANSI Z87.1, Occupational and Educational Eye and Face Protection. Z87.1 is available from the American National Standards Institute, Inc., 1430 Broadway, New York, NY 10018

| | |
|--|--|
|  | CAUTION Personal hearing protection is required at all times when operating or working near this tool. |
|--|--|

Hearing protectors are required in high noise areas, 85dBA or greater. The operation of other tools and equipment in the area, reflective surfaces, process noises and resonant structures can substantially contribute to and increase the noise level in the area. For additional information on hearing protection, refer to federal OSHA regulations, 29 Code of Federal Regulations, section 1910.95, Occupational Noise Exposure and ANSI S12.6 Hearing Protectors.

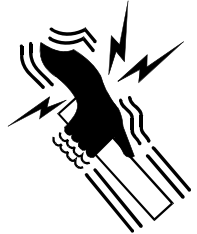
| | |
|--|--|
|  | CAUTION Some individuals are susceptible to disorders of the hands and arms when exposed to tasks which involve repetitive motions and/or vibration. Disorders such as Carpal Tunnel Syndrome and Tendonitis can be caused or aggravated by repetitious, forceful exertions of the hands and arms. |
| <ul style="list-style-type: none">• Use minimum hand grip force.• Keep wrists straight• Avoid prolonged, continuous vibration exposure• Avoid repeated bending of wrists and hands.• Keep arms and hands warm and dry. | |

Section III

**Set Up
&
Operating Procedures**

RS-2

SECTION III

SET-UP AND OPERATION



Valve Maintenance Procedure

A valve that has not been operated for a number of years needs to be closed by using a series of up and down motions. Occasionally, crews attempting to close a difficult valve use a T-handle or a cheater bar, applying a great deal of pressure in one direction simply to force the valve closed. The correct way to exercise a valve is to begin with a steady amount of torque in the direction necessary to close the valve, moving through five to ten rotations, then the direction should be reversed for two or three revolutions, followed by five or ten more turns in the closing direction. This procedure should be repeated until full closure is attained.

The reason for the cautious approach is that tuberculation and sediment have probably built up on the gates, stem, and slides. By using the procedure described, water in the system can flush the debris that has broken away from the gate slide.

The stem is exercised through the series of up and down motions. Once the valve has been fully closed, it should be opened a few turns so that the higher velocity water flowing under the gates can move the remainder of the sediment downstream. After the valve is reopened, it should be turned in the closing direction one or two revolutions. Thus, the next time the valve is operated, it will not be

necessary to start with a nut and stem jammed against the bonnet, and there will be no guesswork about which way to turn the nut because the valve will be free. Also, if it is inadvertently turned the wrong way, one or two turns can be made before a positive stop occurs, and by reversing direction, full operation of the valve can be effected. Using the RS-2 machines to operate valves is easier on the valve because a steady turning torque is applied rather than jerky motions. This prevents the stem breakage that is sometimes caused by turning the valve by hand. Also, more valves can be turned in less time. A further advantage is that information about each valve can be generated automatically by the revolution counter and torque gauges for inclusion on permanent records.

HOW TO DETERMINE AN UNKNOWN VALVE ROTATION:

When the direction to turn the valve stem is not known, select a rotation direction and proceed with caution. If resistance is felt, immediately reverse the rotation. Continue this procedure, reversing direction when resistance is felt, until a free turning direction is achieved. Document the direction, open or closed position, and number of turns required.

RS-2

SECTION III

SET-UP AND OPERATION

I. SET UP PROCEDURE (Valve Key & Socket):

1. Insert 1" drive adaptor into RS-2 drive hub, secure with 1/4 20x5/8" SHCS. (Ref. 1)

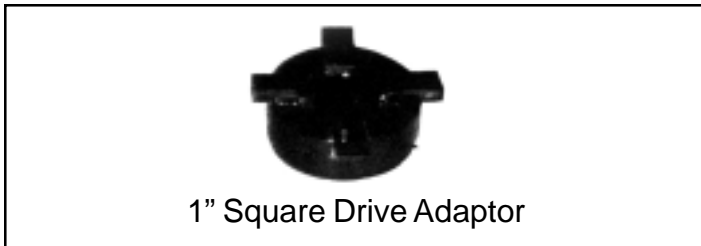

Ref. 1

2. Insert valve key and socket into valve. (Ref. 2)

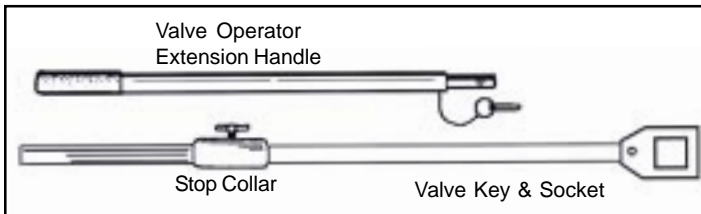

Ref. 2

3. Install stop collar at a comfortable operating height to support the weight of the RS-2.
4. Mount the RS-2 on the valve key and rest on stop collar. Connect the power source.
5. Zero the counter when valve is ready to be turned by pressing the red reset button on the counter face. Always use the counter to determine the number of rotations the valve has turned.
6. Determine direction of valve rotation and which side of RS-2 to operate from. The operator should stand on the side of the machine which allows the torque to **PULL** the machine handle away from his body.



CAUTION: The RS-2 is capable of producing up to 800 ft./lbs. of torque to turn valves. It is very important that proper procedure be exercised when using the valve operating machine.

II. OPERATOR POSITIONING

Standing on the wrong side of the machine will allow the handle to **PUSH** against the operator and can knock him off balance or pin him against an obstacle if torque suddenly increases. When positioned properly, an increase in torque will **PULL** the handle and control out of the operator's hand and stop the machine (See illustrations below).

IMPORTANT: Always refer to the manual or the **valve direction decal** located on valve handle for correct operation positions.

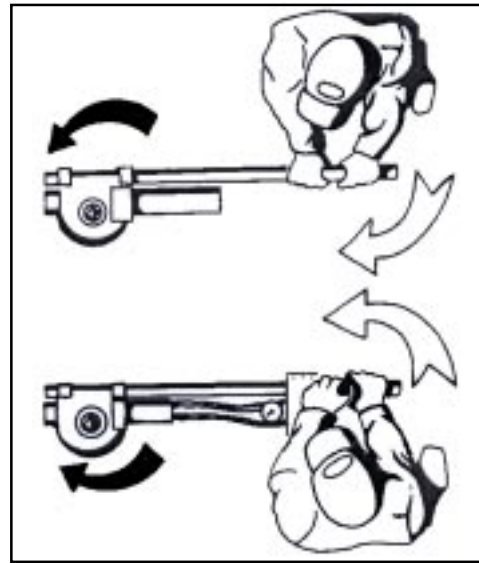

Operator should always change sides for opposite rotation



Valve Key Operation

RS-2

SECTION III

SET-UP AND OPERATION

I. SET UP PROCEDURE

(Universal Handwheel Adapter)

1. Install the 4 handwheel fingers onto the RS-2 rotating drive hub slots with the provided 1/4 20x1" socket head cap screws.
2. Measure the valve handwheel to determine the correct length torque arm required to mount to the universal hand wheel. Install the torque arms using the provided flat head screws and nuts.
3. Set the assembly over the rising stem valve. Center the opening of the universal handwheel adapter over the rising stem screw.
4. Mount the 3 straddle clamps over the torque arms and under the valve handwheel and secure the assembly with the 1/2 13x2" square head screws in the straddle clamps.

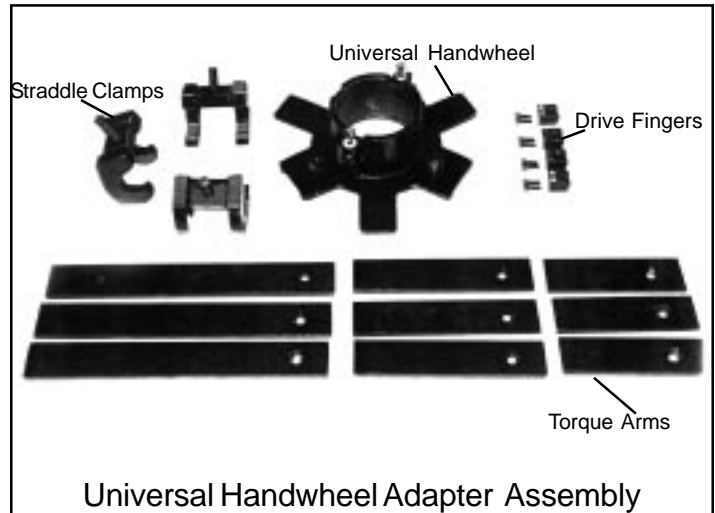

I. SET UP PROCEDURE

(Mounting Dedicated Handwheel Adaptor Plate)

1. The dedicated adaptor plate must be mounted to rising stem valve with U-bolts supplied with your dedicated adaptor plate. Holes must be drilled into adaptor plate to bolt plate to handwheel spokes.



NOTE: Center dedicated handwheel plate hole over center of rising stem screw.



2. After mounting adapter plate, bolt fingers to RS-2 drive hub using the slots provided for this purpose, located on bottom of actuator, using 1/4 20x5/8" socket head cap screws.
3. Place RS-2 on adapter dedicated plate so that fingers rest in adapter plate slots.
4. Insert "fast-pins" in holes provided to lock actuator on adapter plate.
5. Place the RS-2 onto the Universal hand wheel adopter by inserting the 4 drive fingers into the 4 mounting slots on the Universal handwheel adopter. Insert the swing bolt assemblies into the slots and tighten the nuts to secure the assembly.

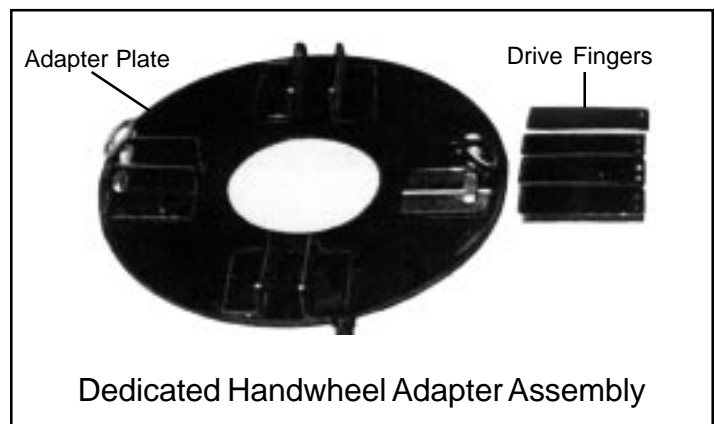

RS-2

SECTION III

SET-UP AND OPERATION

CONTROLS AND COMPONENTS ELECTRIC RS-2

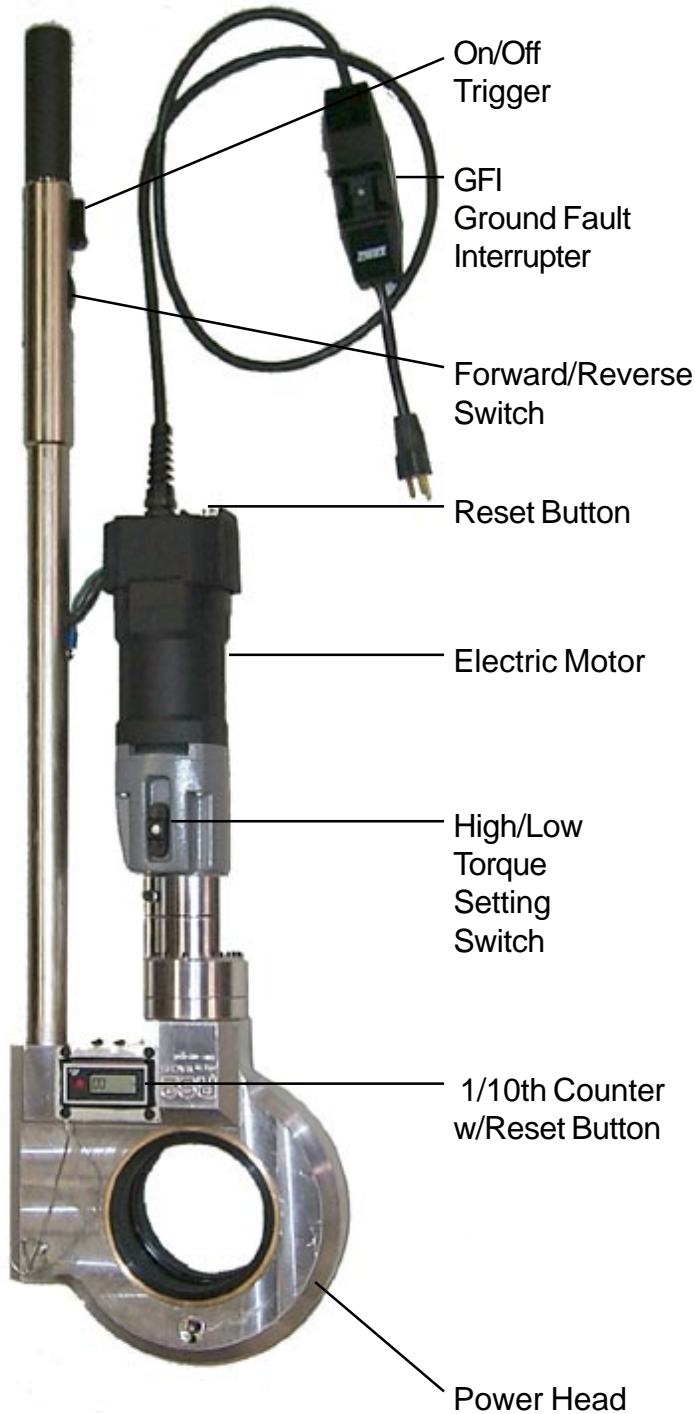

Valve Key Operation

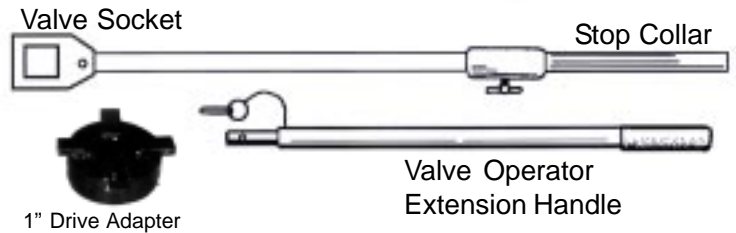

Universal Handwheel Operation

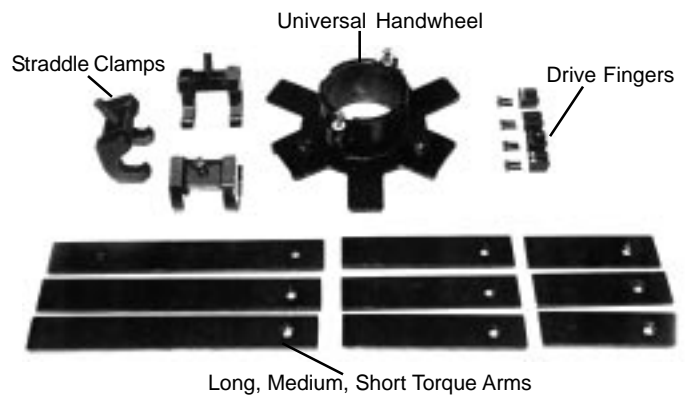

Dedicated Handwheel Operation



CAUTION: DO NOT connect or disconnect hoses to valve operator or power source while power source is operating.

INTRODUCTION

It is impossible to determine how much torque a valve stem can take before breaking. Size, age, condition, tuberculation, and period of time since last operation will have an effect to this. The recommended start-up procedure for operating a valve is to set the RS-2 to its lowest torque setting.

RS-2

SECTION III

SET-UP AND OPERATION

OPERATING PROCEDURE:

ELECTRIC RS-2



CAUTION: Before beginning turning sequence, know which direction to turn the valve to avoid breaking the valve stem.



CAUTION: Only use extension cords rated for 10 AMPS or higher.

1. After plugging in power cord, push reset button on GFI to power up unit.
2. Set speed control knob to high speed/low torque setting (see illustration below).



NOTE: If the motor overload circuit breaker pops while attempting to free a frozen valve, reset the circuit breaker by pressing the reset button and attempt to free the valve again before switching to the low speed/high torque setting.

3. If the valve does not move in either direction, switch speed control to low speed/high torque setting.

Once the valve has started turning, return the speed control switch to the high speed/low torque setting. This procedure will assure you that the machine stops operating as soon as any type of obstruction is encountered or when the valve is seated.



NOTE: More torque will be required to seat, unseat or clear tuberculin from the valve.

DURING OPERATION:

When operating a valve, a build up of torque can be felt by the operator. When this occurs, it is a sign of either build up of material in the valve gate slides or that the end of travel is approaching. The operator should change sides and reverse the valve direction for a few turns, doing this each time resistance is felt. This method of exercising cleans out tuberculin and other contaminant build up. The counter will keep track of how many turns you have put on the valve.

RS-2

SECTION III

SET-UP AND OPERATION

CONTROLS AND COMPONENTS HYDRAULIC RS-2

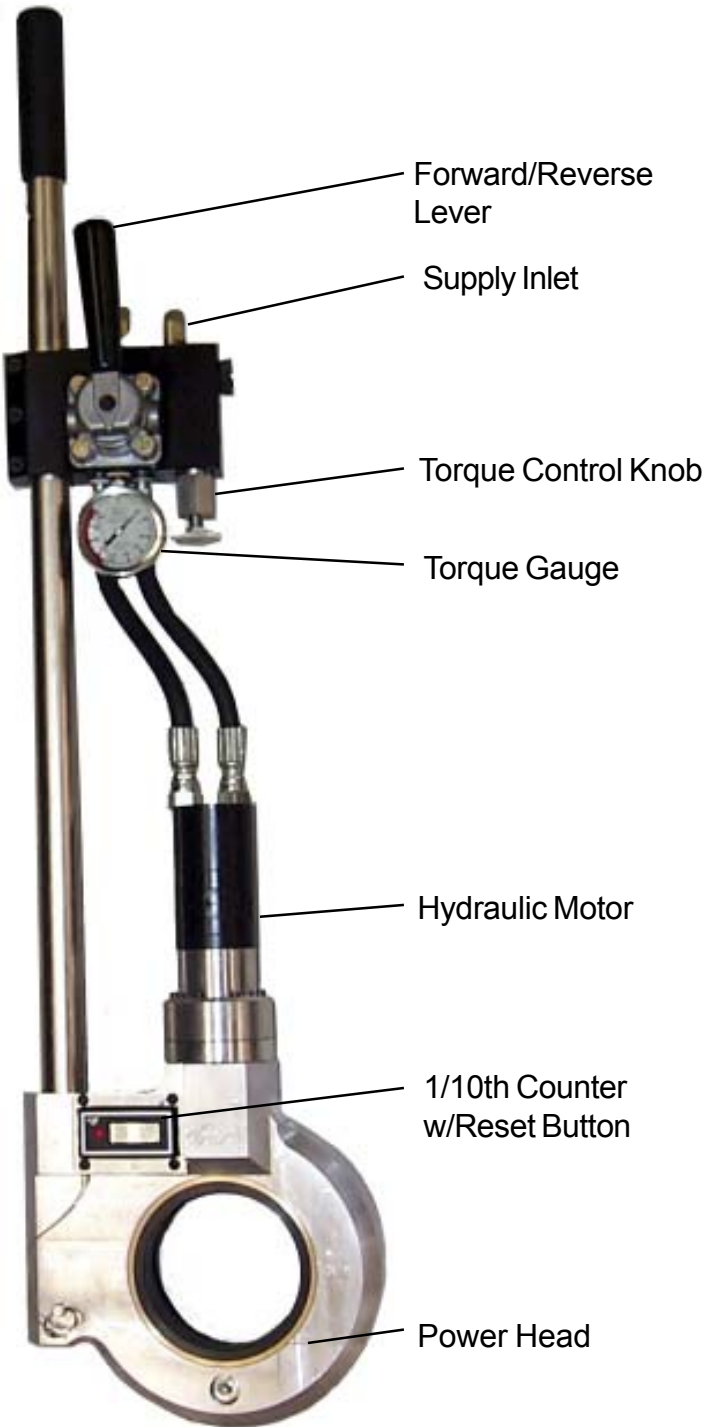

Valve Key Operation

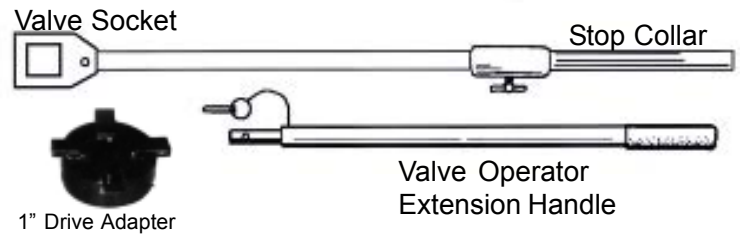

Universal Handwheel Operation

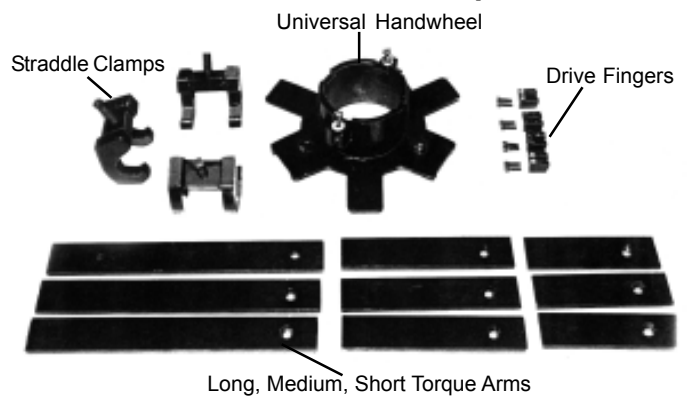

Dedicated Handwheel Operation

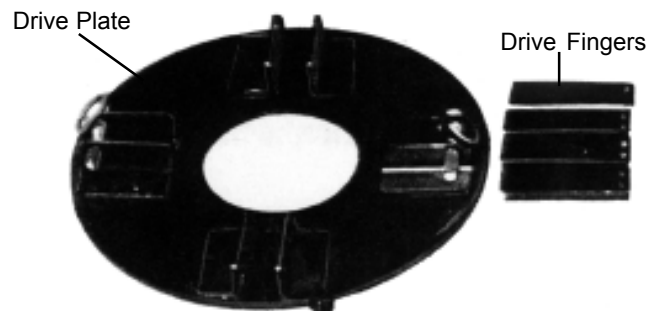

CAUTION: DO NOT connect or disconnect hoses to valve operator or power source while power source is operating.

INTRODUCTION

It is impossible to determine how much torque a valve stem can take before breaking. Size, age, condition, tuberculation, and period of time since last operation will have an effect to this. The recommended start-up procedure for operating a valve is to set the RS-2 to its lowest torque setting.

RS-2

SECTION III

SET-UP AND OPERATION

OPERATING PROCEDURE:

HYDRULIC RS-2



CAUTION: Before beginning turning sequence, know which direction to turn the valve to avoid breaking the valve stem.

1. Rotate torque control knob counterclockwise to the lowest torque setting.
2. Engage the “power on” handle in either forward or reverse direction. If valve does not turn, release handle and engage in the opposite direction.



NOTE: When lever is depressed, torque indicator will read the torque value being applied to valve stem.

3. Continue this process, increasing the torque value 1/2 turn on the torque control until valve stem breaks free. This method ensures that only enough torque is supplied to turn the valve. Once the valve has started turning, reduce the torque setting to the lowest setting which will keep the machine operating. This procedure assures you that the machine will stop operating as soon as any type of obstruction is encountered or valve begins to seat.



NOTE: More torque will be required to seat, unseat or clear tuberculin from the valve.

DURING OPERATION:

When operating a valve, a build up of torque can be felt by the operator. When this occurs, it is a sign of either build up of material in the valve gate slides or that the end of travel is approaching. The operator should change sides and reverse the valve direction for a few turns, doing this each time resistance is felt. This method of exercising cleans out tuberculin and other contaminant build up. The counter will keep track of how many turns you have put on the valve.

RS-2

SECTION III

SET-UP AND OPERATION

CONTROLS AND COMPONENTS

PNEUMATIC RS-2

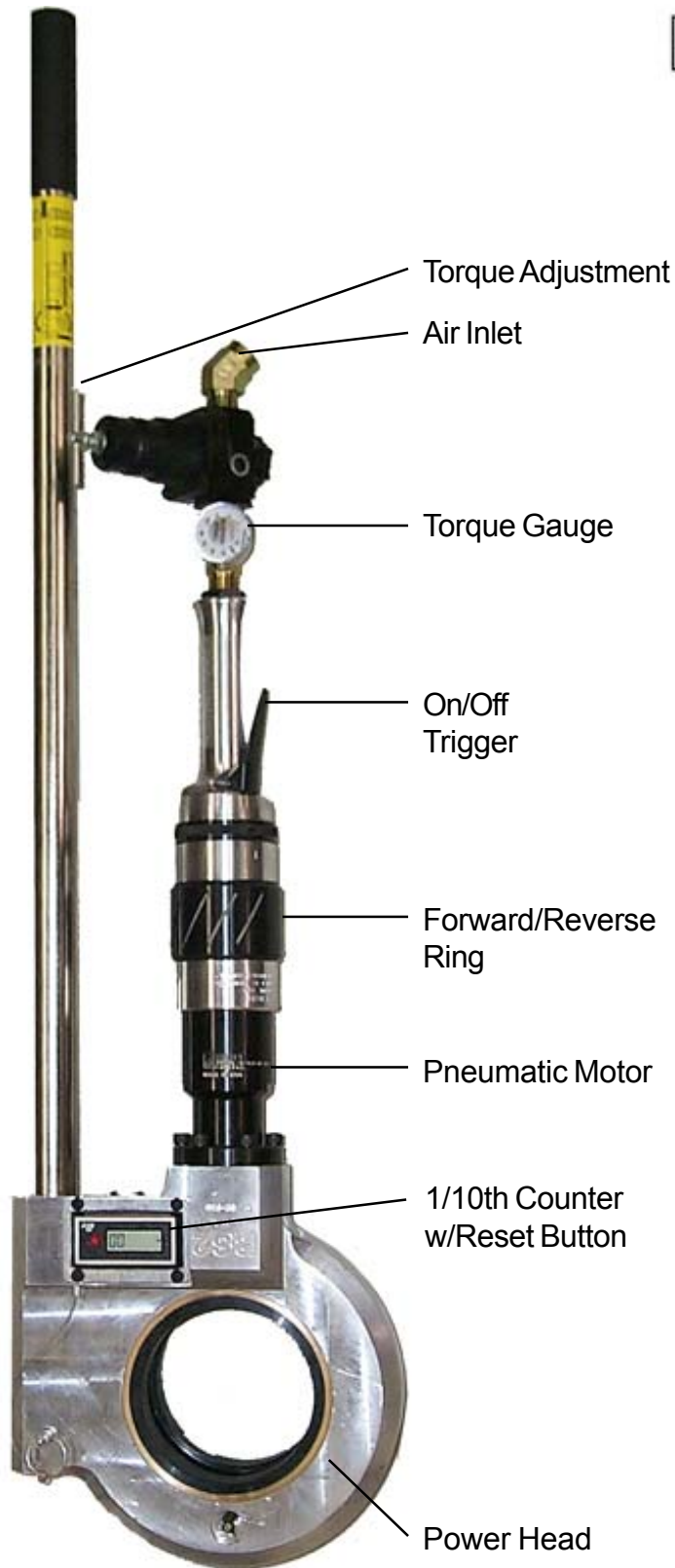

Valve Key Operation

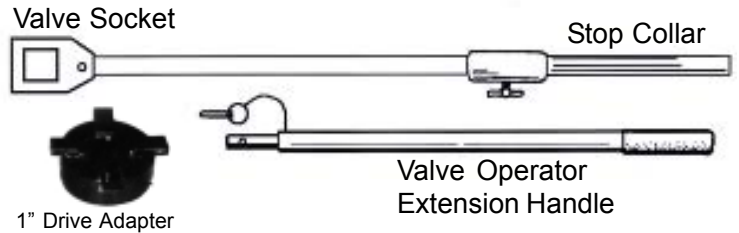

Universal Handwheel Operation

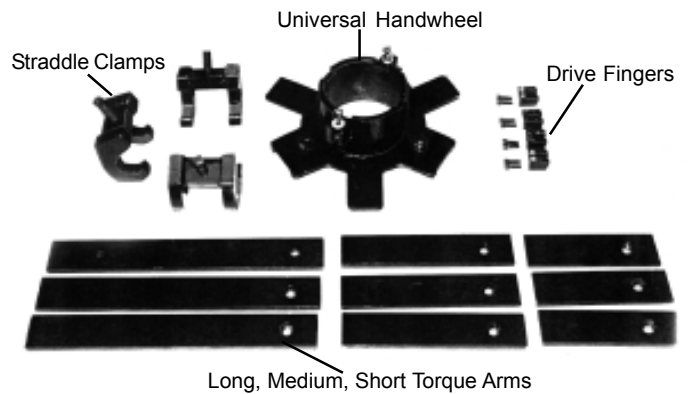

Dedicated Handwheel Operation

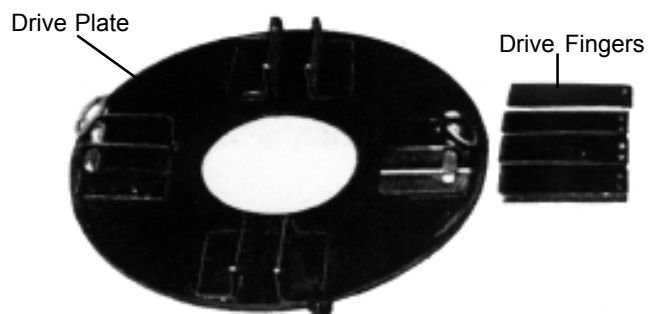

CAUTION: DO NOT connect or disconnect hoses to valve operator or power source while power source is operating.

INTRODUCTION

It is impossible to determine how much torque a valve stem can take before breaking. Size, age, condition, tuberculation, and period of time since last operation will have an effect to this. The recommended start-up procedure for operating a valve is to set the RS-2 to its lowest torque setting

RS-2

SECTION III

SET-UP AND OPERATION

OPERATING PROCEDURE:

PNEUMATIC RS-2

1. Rotate torque control knob counterclock wise to the lowest torque setting
2. Press the power on lever in either forward or reverse direction. If valve does not turn, release lever and rotate motor direction ring on motor body and repeat procedure.



NOTE: When lever is depressed, torque indicator will read the torque value being applied to valve stem.

3. Continue this process, increasing the torque value 1/4 turn on the torque control until valve stem breaks free. This method ensures that only enough torque is supplied to turn the valve. Once the valve has started turning, reduce the torque setting to the lowest setting which will keep the machine operating. This procedure assures you that the machine will stop operation as soon as any type of obstruction is encountered or valve begins to seat.



NOTE:

1. More torque will be required to seat, unseat or clear tuberculin from the valve.
2. Maximum torque cut-off can be reset by free running RS-2 with no load and adjusting torque control until torque indicator gauge reads desired torque cut-off.

DURING OPERATION

When operating a valve, a build up of torque can be felt by the operator. When this occurs, it is a sign of either build up of material in the valve gate slides or that the end of travel is approaching. The operator should change sides and reverse the valve direction for a few turns, doing this each time resistance is felt. This method of exercising cleans out tuberculin and other contaminant build up. The counter will keep track of how many turns you have put on the valve.

USE OF AIR LINE OIL:

An in-line oiling system should be utilized when operating the pneumatic Pow-R-Drive II to lubricate motor on a continuous basis.

When continuous load and high torque settings are required, the use of an antifreeze oil to lubricate the motor will reduce ice buildup and maintain motor performance. (Kilfrost Anti-Freeze Solution, Wachs Part No. 02-403-00)



CAUTION: RS-2 Must be used with an inline filtration system to stop water and air borne contaminants. FAILURE TO COMPLY WILL DAMAGE MOTOR AND VOID WARRANTY.

RS-2

SECTION III

SET-UP AND OPERATION

TWO OPERATOR OPERATION:



An extension handle is provided with each RS-2. It is designed to be inserted into the end of the handle assembly near the powerhead. A convenient quick release pin attached to the extension handle is inserted through the handle and extension to secure them.

An extension handle should be used when the torque required to turn a valve is more than one operator can control easily.

The second operator should stand on the opposite side of the RS-2 as the primary operator. (see photograph) The torque should be pulling the machine handle away from both the secondary and primary operator.

Section IV

Charts & Schematics

RS-2

SECTION IV CHARTS & SCHEMATIC

EIBENSTOCK MOTOR SWITCH SCHEMATIC

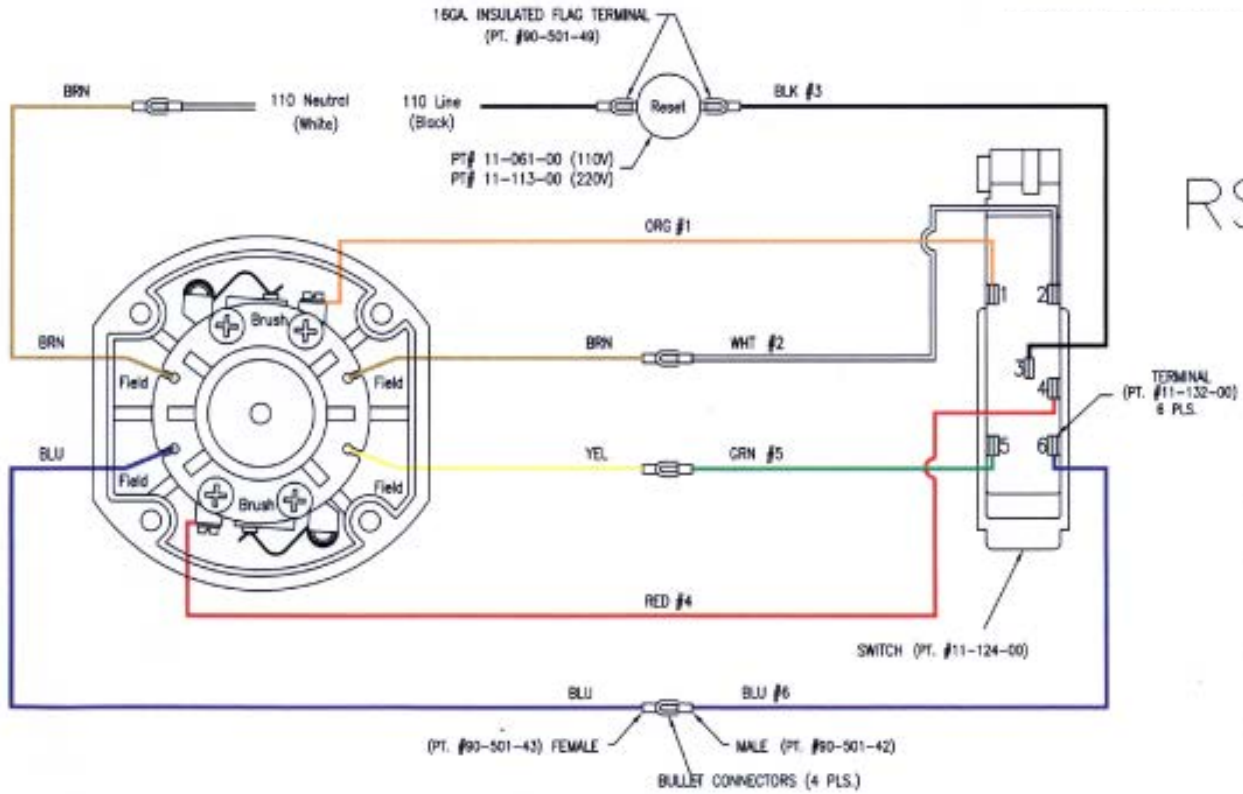

REVOLUTION COUNTER CONNECTION

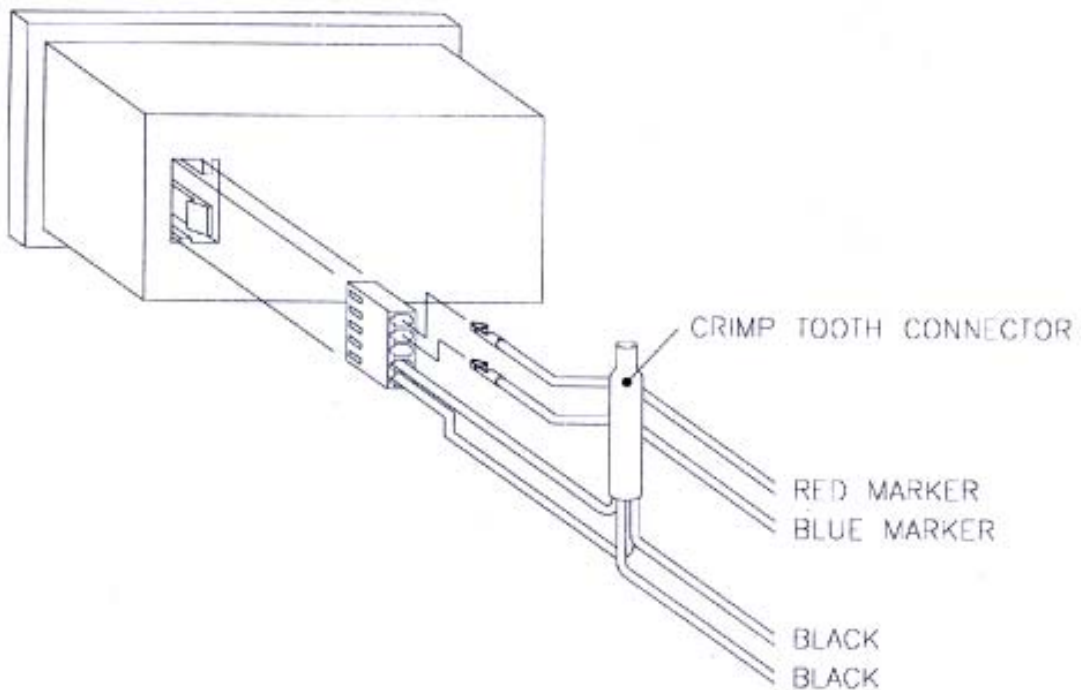

RS-2

SECTION IV

CHARTS & SCHEMATIC

Torque Charts

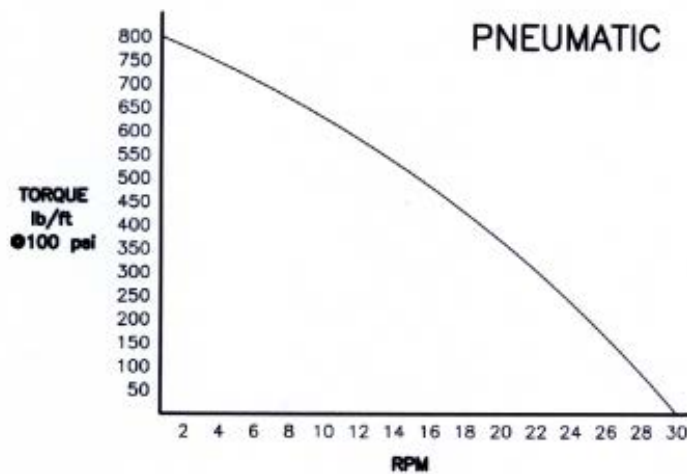
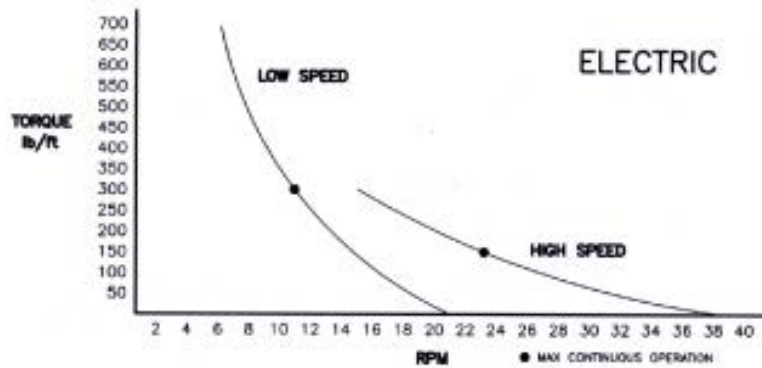
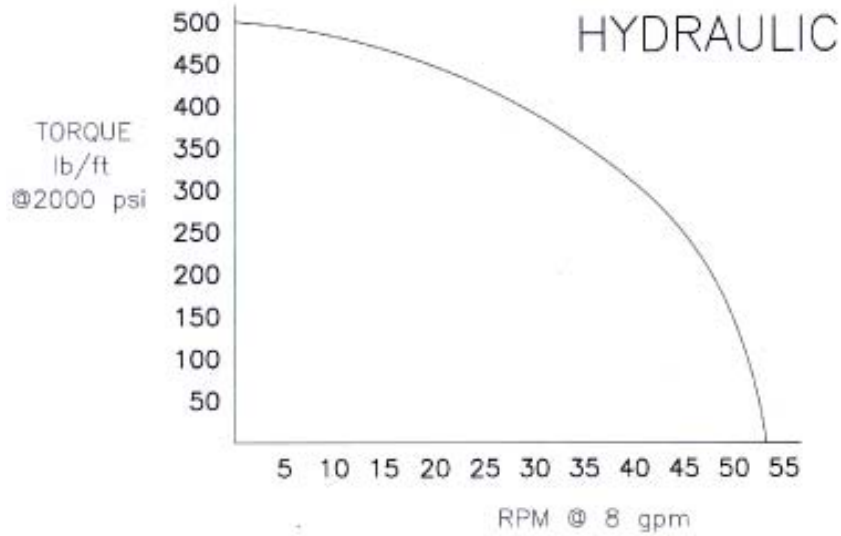

Section V

Bill of Materials

RS-2

Main Head Assembly BOM 78-000-01

| Ref. | Part No. | Qty. | Description |
|----------|-----------|------|---------------------|
| 001 | 78-001-00 | 1 | HOUSING |
| 002 | 78-002-00 | 1 | RETAINER, BEARING |
| 005 | 78-005-00 | 1 | HUB, DRIVE |
| 006 | 78-006-00 | 1 | BUSHING, LOWER |
| 007 | 78-007-00 | 1 | BUSHING, UPPER |
| 015 | 78-015-02 | 1 | .002" SHIM |
| 015 | 78-015-04 | 1 | .004" SHIM |
| 039 | 56-039-00 | 1 | SNAP RING #5101-98* |
| 040 | 56-040-00 | 1 | BEARING,"INA"** |
| NS | 63-026-00 | 10 | MAGNET |
| Fastners | | | |
| 1 | 90-060-10 | 8 | SHCS,5/16-18 X 1 |
| 009 | 66-009-00 | 1 | GEAR, PINION |

Revolution Counter Assembly BOM 78-000-01

| Ref. | Part No. | Qty. | Description |
|----------|-----------|------|---------------------|
| 008 | 78-008-00 | 1 | PLATE, MOUNTING |
| 145 | 11-145-00 | 2 | SENSOR, POSITION |
| 045 | 58-045-00 | 1 | COUNTER, REVOLUTION |
| 121 | 62-121-00 | 1 | LANYARD 6"LG |
| Fastners | | | |
| 1 | 90-501-46 | 1 | CONNECTOR, MOLEX |
| 2 | 90-042-03 | 4 | BHCS,10-24 X 3/8 |
| 3 | 90-079-20 | 1 | PIN,FAST3/8 X 2 1/8 |
| 4 | 90-500-05 | 1 | GRSE.FTG,1/4-28 STR |

RS-2

Main Head Assembly BOM 78-000-01

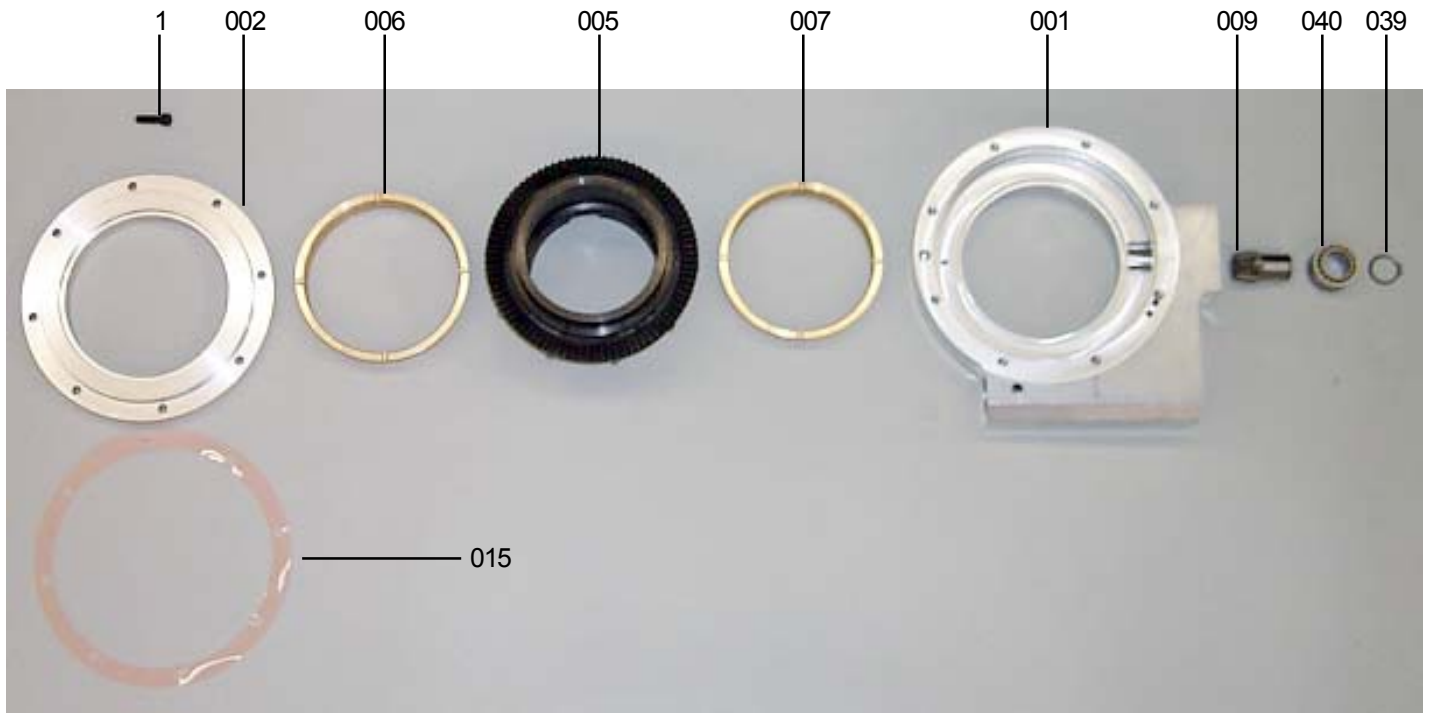

Revolution Counter Assembly BOM 78-000-01

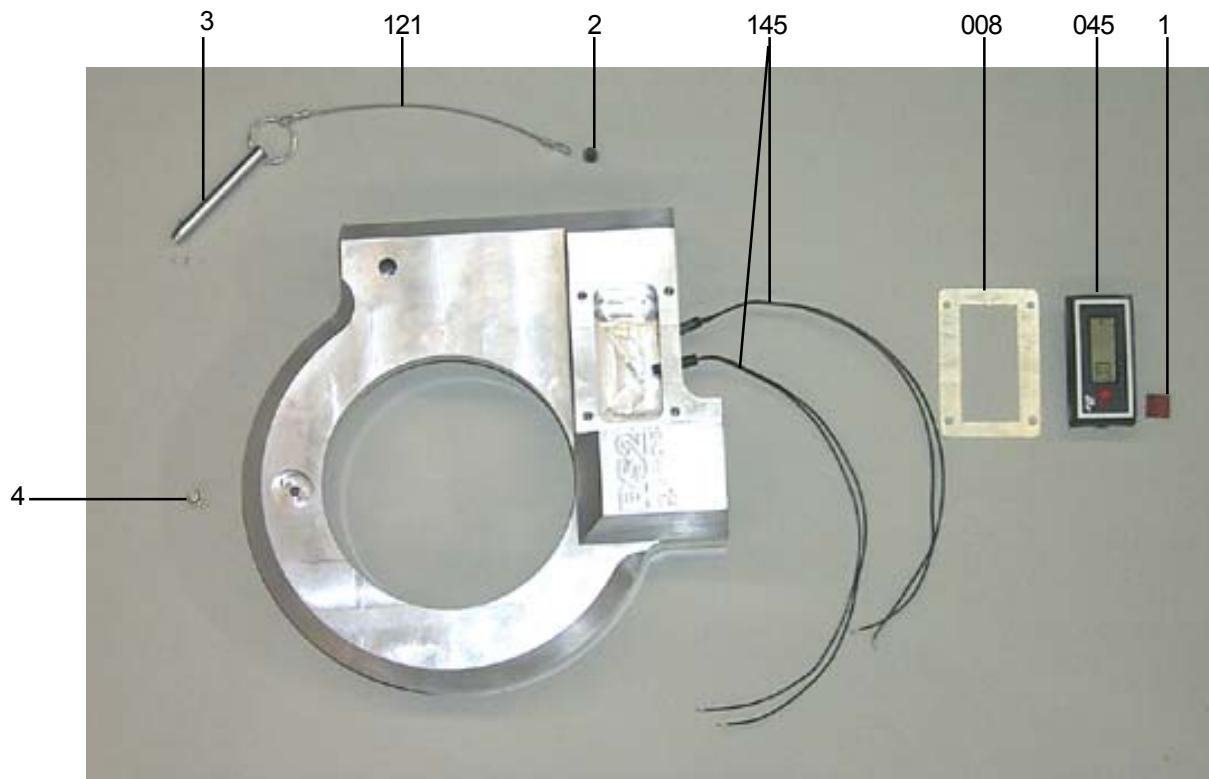

RS-2

Hydraulic Drive Assembly BOM 78-000-04

| Ref. | Part No. | Qty. | Description |
|----------|-----------|------|----------------------|
| 010 | 78-010-00 | 1 | PLATE, ADAPTER |
| 199 | 02-199-00 | 1 | KEY, DRIVE |
| 013 | 78-013-00 | 1 | HOUSING, GEARSET-HYD |
| 014 | 78-014-00 | 1 | COUPLING, INPUT |
| NS | 11-044-00 | 1 | HANDLE EXTENSION |
| 054 | 11-054-00 | 2 | GRIP, RUBBER |
| 081 | 11-081-00 | 1 | BAR, HANDLE - AIR |
| 088 | 11-088-00 | 2 | HOSE, HYDRAULIC |
| 089 | 11-089-00 | 1 | HANDLE, TAPERED* |
| 092 | 11-092-00 | 1 | MOTOR* |
| 103 | 11-103-00 | 1 | GEAR, PLANETARY* |
| 110 | 11-110-00 | 1 | GAUGE, TORQUE* |
| 141 | 11-141-00 | 1 | MANIFOLD* |
| 142 | 11-142-00 | 1 | REGULATOR, PRI.FLOW |
| 116 | 05-116-00 | 1 | VALVE, RELIEF* |
| 151 | 05-151-00 | 1 | VALVE, REVERSING* |
| 048 | 70-048-00 | 1 | RING, SPACER |
| NS | 78-MAN-01 | 1 | MANUAL, RS2 |
| NS | 78-016-00 | 1 | CASE, STORAGE |
| 011 | 78-011-00 | 1 | SHAFT, OUTPUT |
| Fastners | | | |
| 1 | 90-020-15 | 7 | SHCS, 8-32 X 1 1/2 |
| 2 | 90-028-01 | 6 | SHPP, 1/8 DRYSEAL |
| 3 | 90-050-67 | 5 | SHCS, 1/4-28X1-3/4 |
| 4 | 90-060-08 | 3 | SHCS, 5/16-18 X 7/8 |
| 5 | 90-075-65 | 1 | SSS, 3/8-16 X 1-1/2 |
| 6 | 90-178-01 | 2 | ST.EL 3/8NPT-45 |

Pneumatic Drive Assembly BOM 78-000-03

| Ref. | Part No. | Qty. | Description |
|----------|-----------|------|----------------------|
| NS | 11-044-00 | 1 | HANDLE EXTENSION |
| 054 | 11-054-00 | 2 | GRIP, RUBBER |
| 081 | 11-081-00 | 1 | BAR, HANDLE - AIR |
| 093 | 11-093-01 | 1 | REGULATOR* |
| 093 | 11-093-02 | 1 | GAUGE, 1.5"X1/8"PIPE |
| 137 | 11-137-00 | 1 | NIPPLE |
| 017 | 78-017-00 | 1 | MOTOR, PNEUMATIC |
| NS | 78-016-00 | 1 | CASE, STORAGE |
| NS | 78-MAN-01 | 1 | MANUAL, RS2 |
| Fastners | | | |
| 1 | 90-098-62 | 1 | ST.EL, 1/2-45DEG |
| N/S | 90-060-10 | 6 | SHCS 5/16-18X1" |

RS-2

Hydraulic Drive Assembly BOM 78-000-04

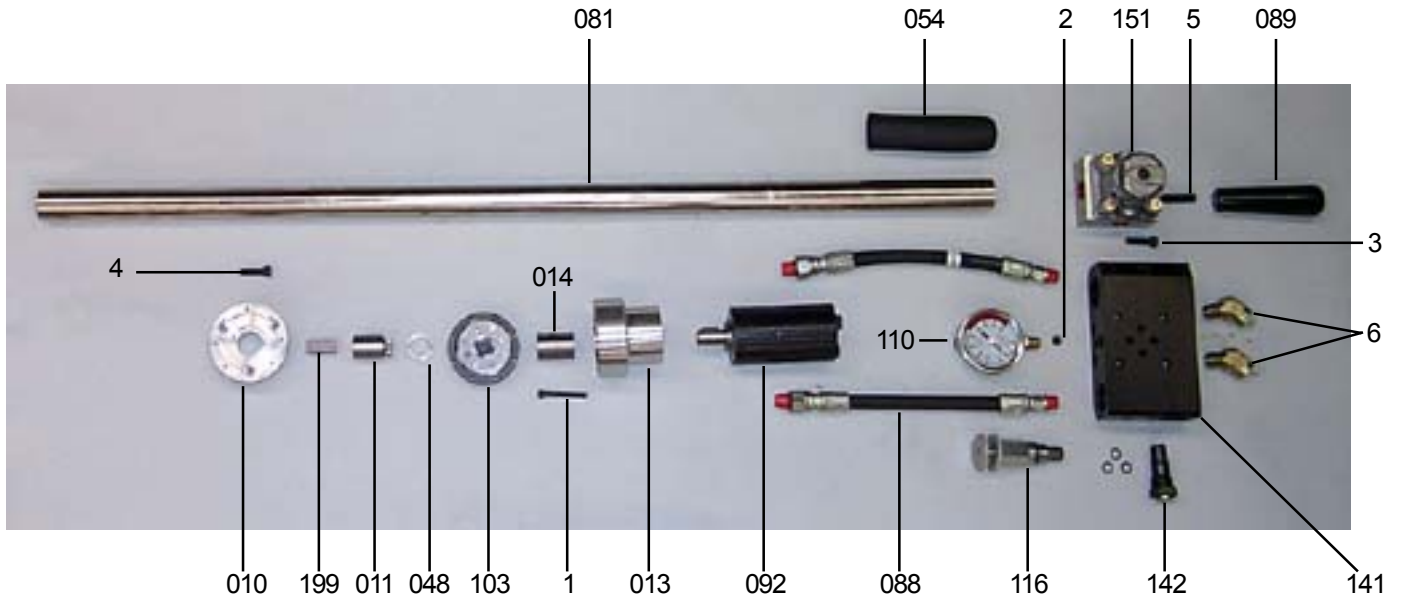

Pneumatic Drive Assembly BOM 78-000-03

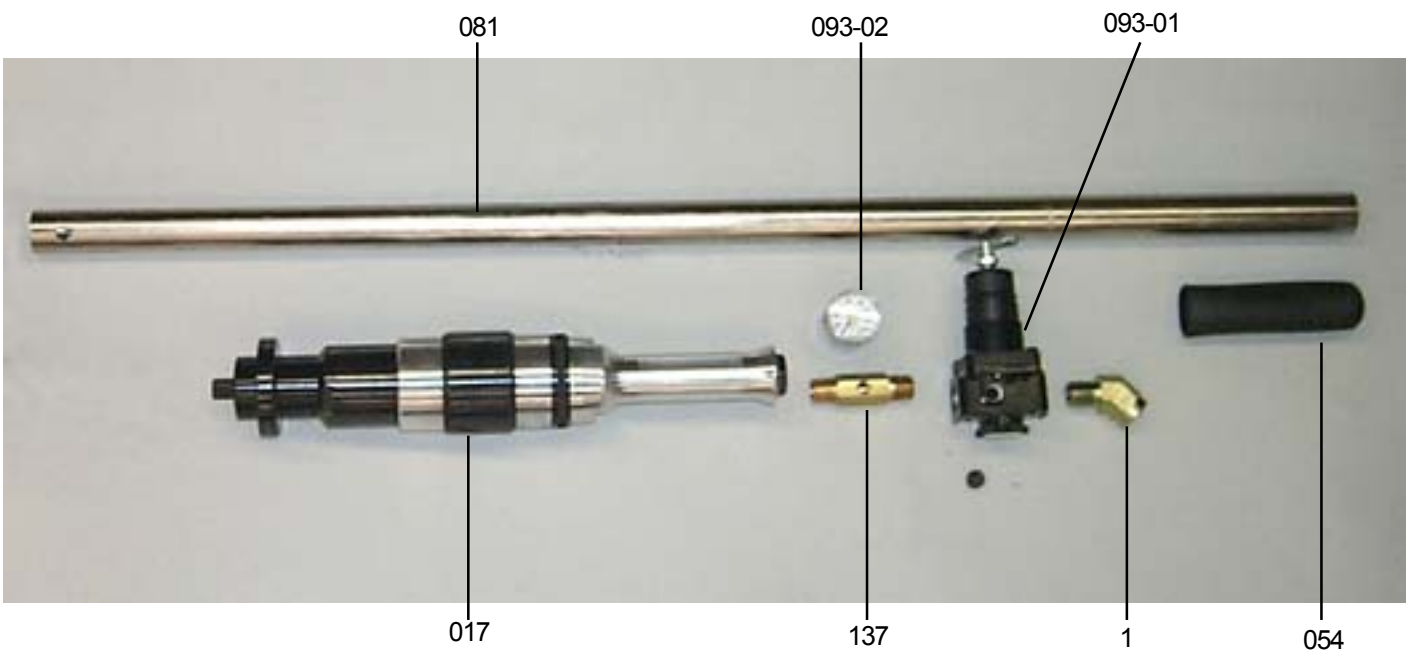

RS-2

Electric Drive Assembly BOM 78-000-01

| Ref. | Part No. | Qty. | Description |
|-----------|-----------|------|-------------------------|
| 009 | 78-009-01 | 1 | HOUSING, GEARSET |
| 010 | 78-010-00 | 1 | PLATE, ADAPTER |
| 011 | 78-011-00 | 1 | SHAFT, OUTPUT |
| 199 | 02-199-00 | 1 | KEY, DRIVE |
| NS | 11-044-00 | 1 | HANDLE EXTENSION |
| 054 | 11-054-00 | 2 | GRIP, RUBBER |
| 122 | 11-122-00 | 1 | WELDMENT, SWITCH HNDL |
| 123 | 11-123-00 | 1 | HOUSING, SWITCH |
| 124 | 11-124-00 | 1 | SWITCH, MODIFIED |
| 131 | 11-131-00 | 22" | WIRE, 6COND. 16GA. POLY |
| NS | 11-132-00 | 6 | TERMINAL, END |
| NS | 11-133-00 | 1 | GROMMET, RUBBER |
| NS | 11-134-00 | 1 | PLUG, #4 RUBBER |
| NS | 11-135-00 | 1 | PLUG, #6 RUBBER |
| 103 | 11-103-00 | 1 | GEAR, PLANETARY* |
| 018 | 78-018-00 | 1 | MOTOR |
| 020 | 78-020-00 | 1 | BLANKING PLATE |
| 041 | 11-041-00 | 1 | INTERRUPTER, CIRCUIT |
| 061 | 11-061-00 | 1 | BUTTON, RESET |
| NS | 11-069-00 | 1 | LABEL, GFI RESET |
| 048 | 70-048-00 | 1 | RING, SPACER |
| NS | 78-MAN-01 | 1 | MANUAL, RS2 |
| NS | 78-016-00 | 1 | CASE, STORAGE |
| Fasteners | | | |
| 1 | 90-042-06 | 2 | BHCS, 10-32 X 3/8 |
| NS | 90-501-42 | 4 | TERM, 16GA. BULLET-M |
| NS | 90-501-49 | 2 | 1/4 FLAG, INSULATED |
| 2 | 90-020-15 | 8 | SHCS, 8-32 X 1 1/2 |
| 3 | 90-050-08 | 1 | SHCS, 1/4-20 X 7/8 |
| 4 | 90-060-08 | 3 | SHCS, 5/16-18 X 7/8 |

RS-2

Electric Drive Assembly
BOM 78-000-01

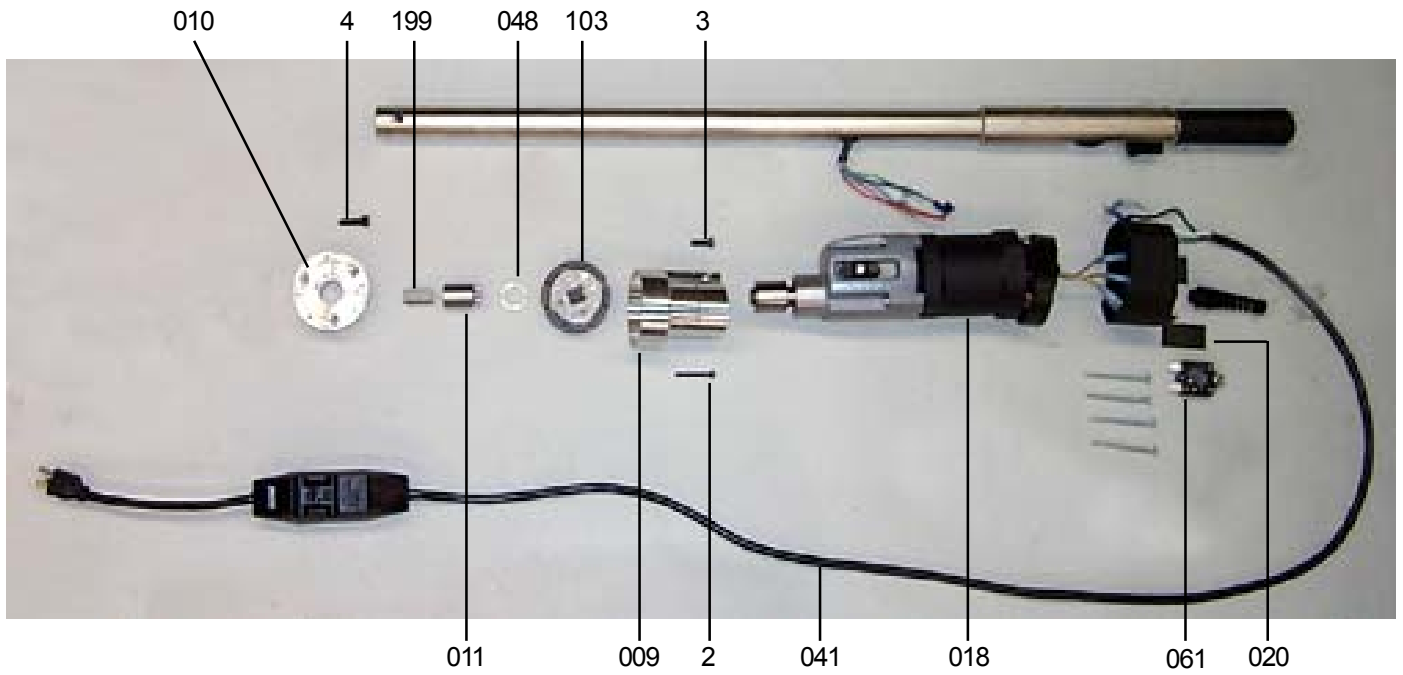
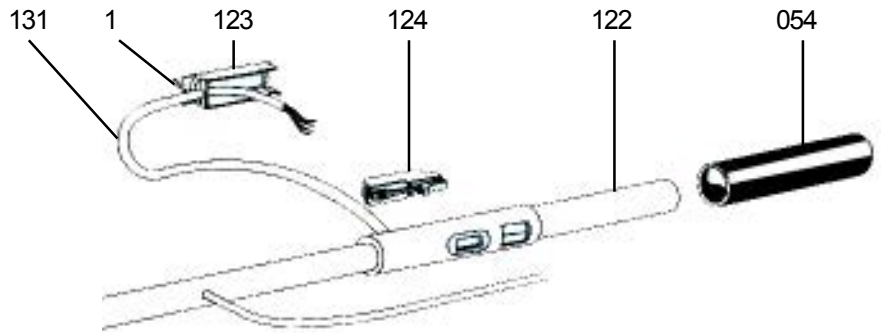

RS-2

Universal Handwheel

| Ref. | Part No. | Qty. | Description |
|------|-----------|------|--------------------------|
| 36 | 09-036-00 | 1 | HUB, UNIVERSAL HANDWHEEL |
| 37 | 09-037-01 | 3 | CLAMP, STRADDLE |
| 38 | 09-038-01 | 3 | ARM, SHORT TORQUE |
| 38 | 09-038-02 | 3 | ARM, MEDIUM TORQUE |
| 38 | 09-038-03 | 3 | ARM, LONG TORQUE |
| 48 | 09-048-00 | 2 | EYE BOLT |
| 61 | 09-061-00 | 4 | FINGER, HANDWHEEL DRIVE |
| 99 | 90-099-01 | 3 | SCREW, 1/2-13 X 2 SQ HD |
| NS | 90-050-10 | 8 | SHCS, 1/4-20 X 1 |
| NS | 90-056-10 | 2 | PIN, DOWEL 1/4 X 1 |
| NS | 90-065-01 | 2 | NUT, HEX 5/16-18 |
| NS | 90-065-52 | 2 | WASHER, 5/16 FLAT |
| NS | 90-073-12 | 3 | FHCS, 3/8-16 X 1-1/4 |
| NS | 90-075-01 | 3 | NUT, HEX 3/8-1/6 |

1" Inch Drive Adaptor

| Ref. | Part No. | Qty. | Description |
|------|-----------|------|---------------------|
| 18 | 09-018-00 | 1 | 1" DRIVE ADAPTOR |
| NS | 90-050-06 | 2 | SHCS, 1/4-20 X 5/8" |

Handwheel Adaptor Plate

| Ref. | Part No. | Qty. | Description |
|------|-----------|------|------------------------|
| 6 | 09-006-00 | 4 | FINGER, DRIVE |
| 40 | 09-040-00 | 1 | PLATE, HANDWHEEL DRIVE |
| NS | 90-050-06 | 8 | SHCS, 1/4-20 X 5/8 |
| NS | 90-079-20 | 4 | PIN, FOAST 3/8 X 2-1/8 |
| NS | 90-900-11 | 4 | BOLT, 1-3/8 X 2-3/16 |

RS-2

1" Inch Drive Adaptor
Handwheel Adaptor Plate
Universal Handwheel

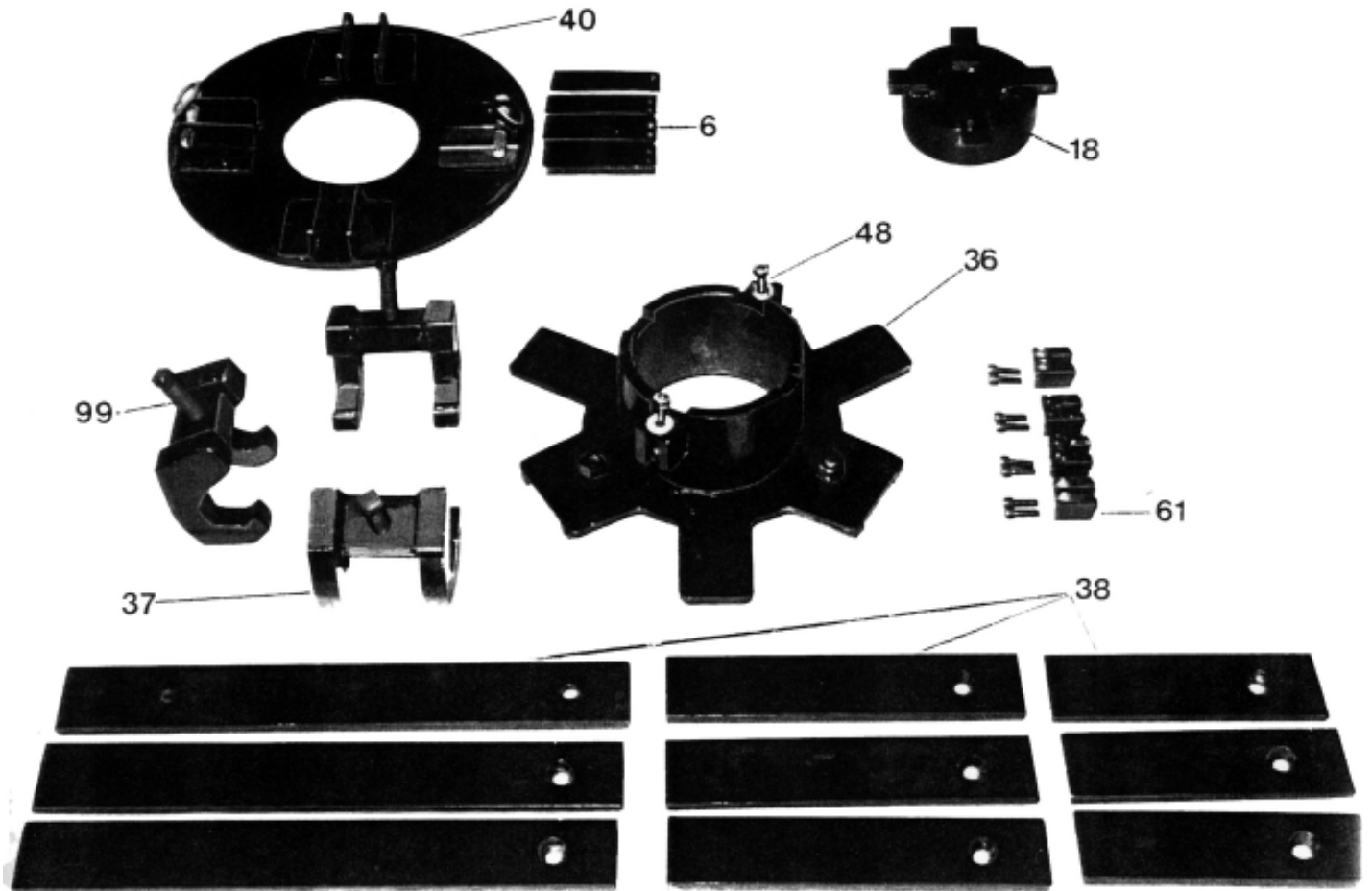

RS-2

Bill of Material RS-2 Accessories

| REF | PART NO | QTY | DESCRIPTION |
|-----|-----------|-----|--------------------------|
| 34 | 05-034-00 | 1 | STOP/COUPLING COLLAR |
| 35 | 05-035-00 | 1 | LOCKING SCREW |
| 36 | 05-036-00 | 1 | 2" SOCKET |
| 37 | 05-037-00 | 1 | 8 FT. LONG KEY |
| 42 | 90-042-00 | 1 | BHCS, 10-32 x 1/4" |
| 44 | 11-044-00 | 1 | EXTENSION, HANDLE ASSY |
| 45 | 11-045-00 | 1 | PIN, QUICK RELEASE |
| 54 | 11-054-00 | 1 | GRIP RUBBER |
| 82 | 05-082-00 | 1 | AIR LINE OILER ASSY |
| 64 | 90-098-01 | 1 | 1/2" CLOSE NIPPLE LP. |
| 86 | 90-098-10 | 1 | BUSHING, RED 1/2 x 3/4 |
| 130 | 90-076-75 | 1 | 3/8 X 2-1/2 ROLL PIN |
| 132 | 90-218-00 | 1 | 3/4 X 1-1/4 GALV BUSHING |
| 136 | 05-136-00 | 1 | 15/16 DRIVE SOCKET |
| 138 | 05-138-00 | 1 | DRIVE KEY |
| 12 | 62-121-00 | 1 | LANYARD 6.0 |
| 139 | 90-056-70 | 1 | 1/4 X 2 ROLL PIN |
| 163 | 02-163-00 | 1 | FILTER BODY |
| 164 | 02-164-00 | 1 | FILTER ELEMENT |
| 192 | 02-192-00 | 1 | END PLUG |
| N/S | 05-061-01 | 1 | 6FT.X1/2HOSEWHIP |
| N/S | 05-403-00 | 1 | 4 FT. VALVE KEY EXT. |
| N/S | 02-401-00 | 1 | H.D. WORM GEAR OIL/QT |
| N/S | 02-402-00 | 1 | AIR MOTOR OIL/i GALLON |
| N/S | 02-403-00 | 1 | ANTI-FREEZE/1 GALLON |
| N/S | 03-404-00 | 1 | 45 FT 1/2 HYD HOSE ASSY |

RS-2

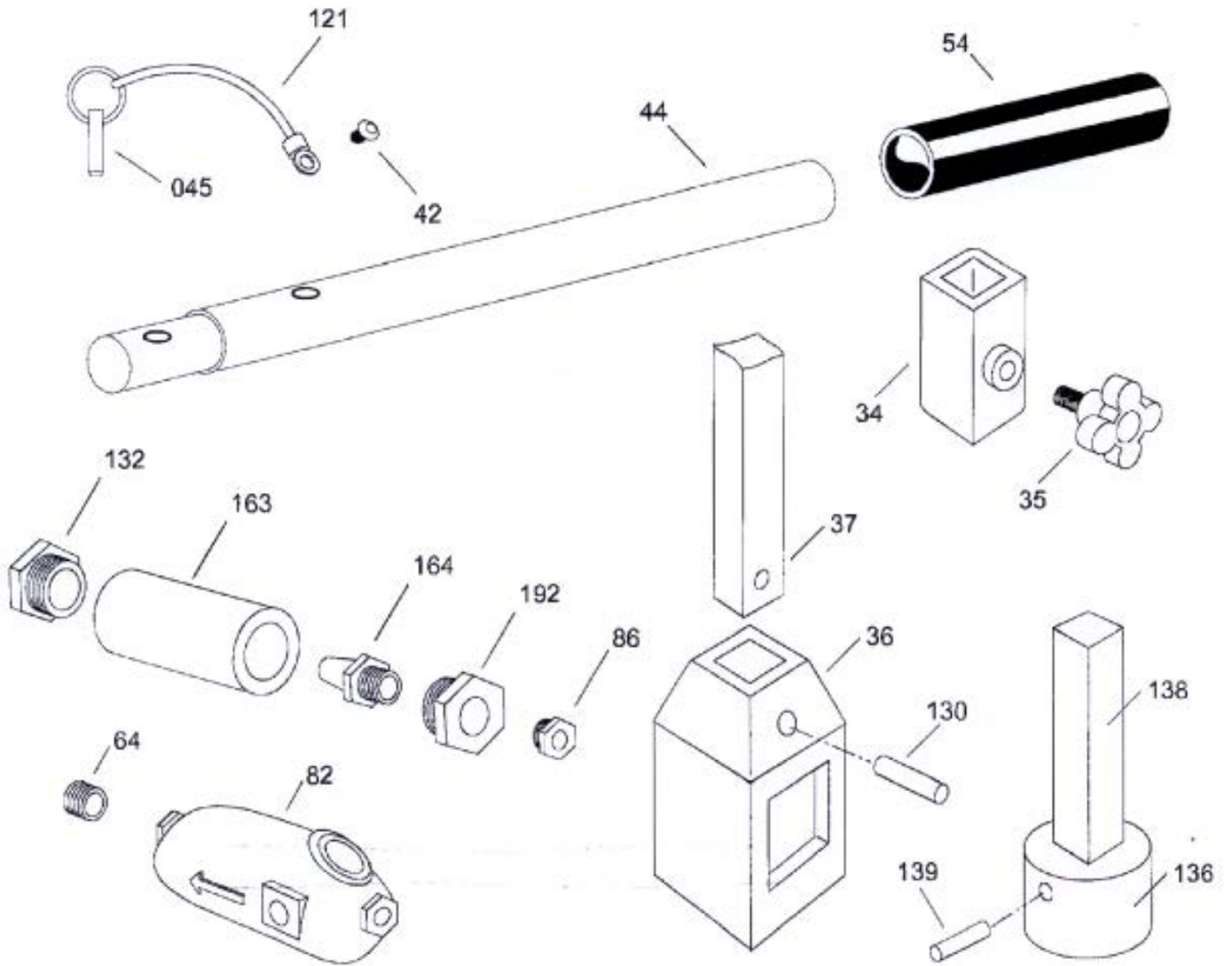

CLECO AIR MOTOR

**SPINDLES AND GEAR TRAINS
FOR 75 IN-LINE FIXTURE
MOUNTED NUTRUNNERS
WITH LS & LR SPINDLES**
(LS-SOLID SPINDLE —
LR-RETRACTABLE SPINDLE)

201065 COMPLETE SUBASSEMBLY

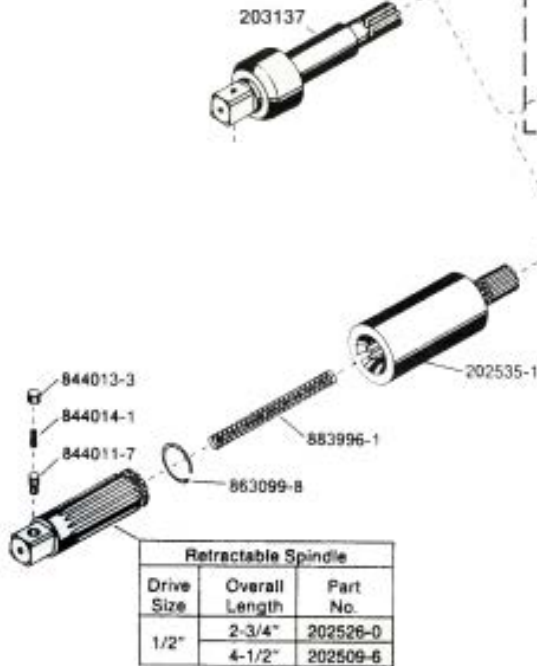
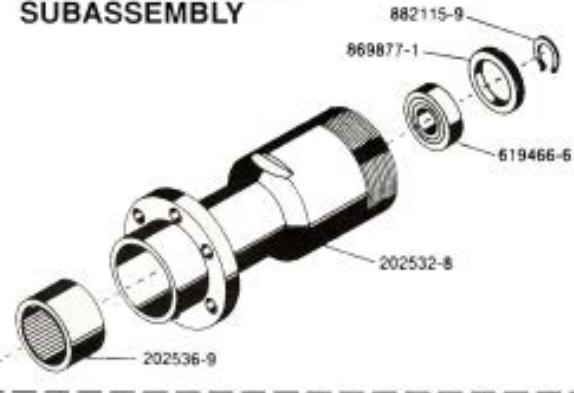

PARTS LIST — GEAR CASE

| PART NO. | NAME OF PART | QTY. |
|----------|---|------|
| 202509-6 | 1/2" Sq. Dr. Retractable Spindle (LR 1/2-3-3/4) | 1 |
| 202526-0 | 1/2" Sq. Dr. Retractable Spindle (LR 1/2-2) | 1 |
| 202532-8 | Gear Case (50T) | 1 |
| 202533-6 | 1/2" Sq. Dr. Solid Spindle (LS 1/2-13/16) | 1 |
| 202535-1 | Spindle Driver | 1 |
| 202536-9 | Needle Bearing | 1 |
| 619466-6 | Ball Bearing | 1 |
| 844011-7 | Socket Lock Pin | 1 |
| 844013-3 | Retainer Plug | 1 |
| 844014-1 | Lock Pin Spring | 1 |
| 863099-8 | Retainer Clip | 1 |
| 864710-9 | Lock Pin Retainer | 1 |
| 864711-7 | Socket Lock Pin | 1 |
| 864712-5 | Lock Pin Spring | 1 |
| 869877-1 | Bearing Retainer | 1 |
| 882115-9 | Retainer Ring | 1 |
| 883996-1 | Spindle Spring | 1 |

NOTE: All Spindles include socket pin, spring, and retainer.

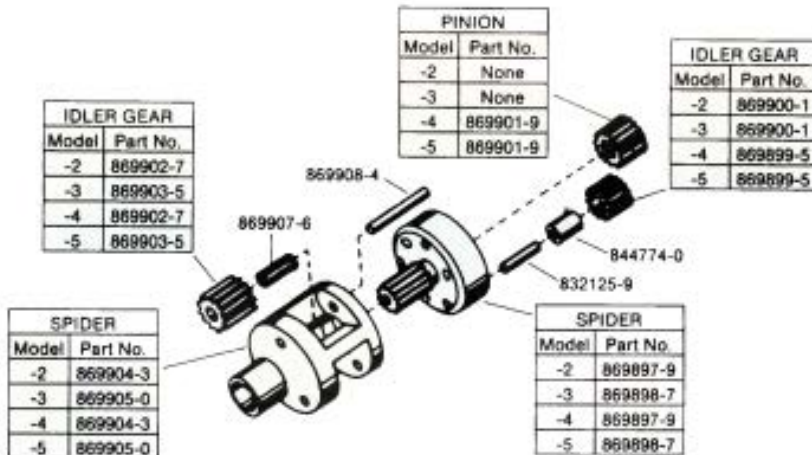

PARTS LIST — GEAR TRAINS

| PART NO. | NAME OF PART | QTY. | PART NO. | NAME OF PART | QTY. |
|----------|--|------|----------|-----------------------------|------|
| 832125-9 | Idler Gear Pin | 6 | 869902-7 | -2 & -4 Idler Gear (18T) | 3 |
| 844774-0 | Idler Gear Bearing | 3 | 869903-5 | -3 & -5 Idler Gear (15T) | 3 |
| 869897-9 | -2 & -4 Spider (13T)- Incl. 832125-9 | 1 | 869904-3 | -2 & -4 Spider | 1 |
| 869898-7 | -3 & -5 Spider (19T)- Incl. 832125-9 | 1 | 869905-0 | -3 & -5 Spider | 1 |
| 869899-5 | -4 & -5 Idler Gear (17T)- Incl. 844774-0 | 3 | 869907-6 | Needle Roller (13 Per Gear) | 39 |
| 869900-1 | -2 & -3 Idler Gear (21T)- Incl. 844774-0 | 3 | 869908-4 | Idler Gear Pin | 3 |
| 869901-9 | -4 & -5 Pinion Gear (16T) | 1 | | | |

CLECO AIR MOTOR

NO. 75 M, MT, RM & MA FIXTURE MOUNTED TOOL GEAR TRAINS

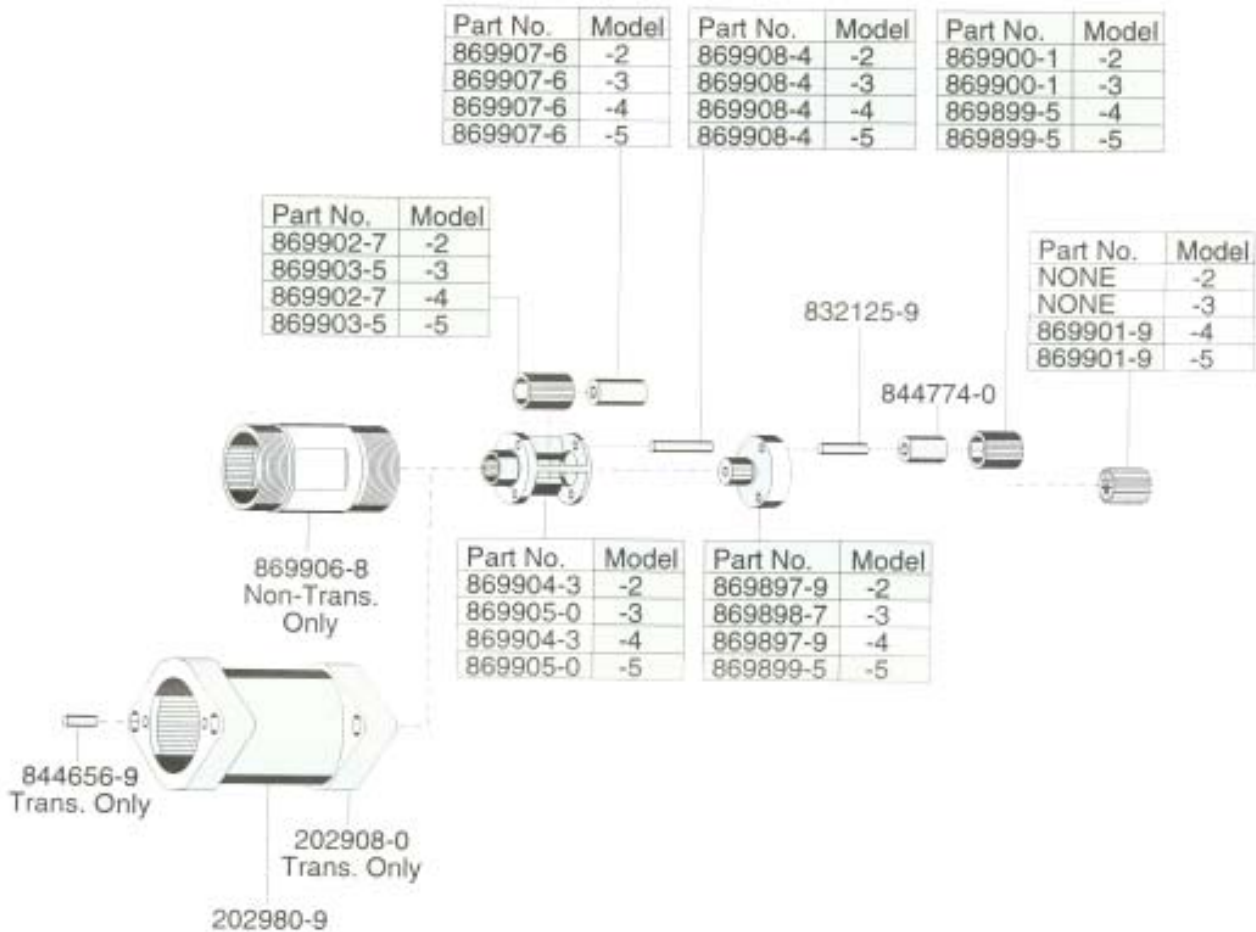

PARTS LIST — GEAR TRAINS

| PART NO. | NAME OF PART | QTY. | PART NO. | NAME OF PART | QTY. |
|----------|---|------|----------|---|------|
| 202908-0 | Ring Gear (Trans. Only)* | 1 | 869900-1 | -2 & -3 Idler Gear (21T) Incl. 844774-0 | 3 |
| 202980-9 | Monogram | 1 | 869901-1 | -4 & -5 Pinion Gear (16T) | 1 |
| 832125-9 | Idler Gear Pin | 6 | 869902-7 | -2 & -4 Idler Gear (18T) | 3 |
| 844656-9 | Dowel Pin (Trans. Only)* | 2 | 869903-5 | -3 & -5 Idler Gear (15T) | 3 |
| 844774-0 | Idler Gear Bearing | 3 | 869904-3 | -2 & -4 Spider | 1 |
| 869897-9 | -2 & -4 Spider - Incl. 832125-9 | 1 | 869905-0 | -3 & -5 Spider | 1 |
| 869898-7 | -3 & -5 Spider- Incl. 832125-9 | 1 | 869906-8 | Gear Case (50T) | 1 |
| 869899-5 | -4 & -5 Idler Gear (17T) Incl. 844774-0 | 3 | 869907-6 | Needle Roller (13 Per Gear) | 39 |
| | | | 869908-4 | Idler Gear Pin | 3 |

The complete Non-Transducerized Gear Trains can be purchased as a subassembly using the following part numbers:
 -2 - 861915-7, -3 - 861914-0, -4 - 861913-2, -5 - 861912-4. Ring Gear is not included in Gear Trains.

The complete Transducerized Gear Trains can be purchased as a subassembly using the following part number:
 -2 - 201361-3, -3 - 201362-1, -4 - 201363-9, -5 - 201364-7.

*Parts not included in subassemblies

CLECO AIR MOTOR

**NO. 75 HANDLE
AND MOTOR
FOR
RNAL, NAL, RNL,
NL & NJL NUTRUNNERS**

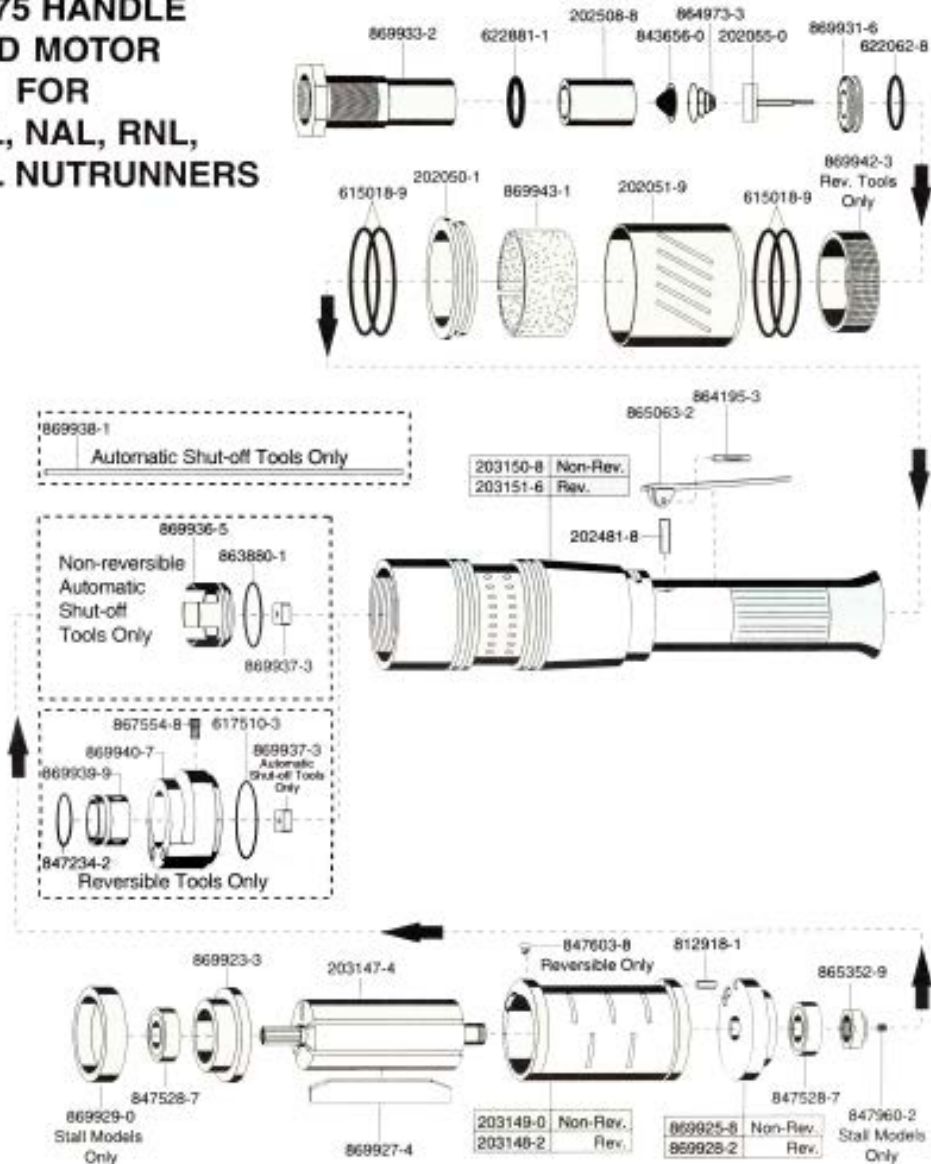

| PART NO. | NAME OF PART | QTY. | PART NO. | NAME OF PART | QTY. |
|----------|---|------|----------|--|------|
| 202050-1 | Deflector Spacer | 1 | 863880-1 | "O"-Ring 1-1/4" x 1-3/8" | 1 |
| 202051-9 | Exhaust Deflector | 1 | 864195-3 | Throttle Lever Pin | 1 |
| 202055-0 | Throttle Valve | 1 | 864973-3 | Throttle Valve Spring | 1 |
| 202481-8 | Throttle Valve Pin | 1 | 865063-2 | Throttle Lever | 1 |
| 202508-8 | Inlet Spacer | 1 | 865352-9 | Rotor Lock Nut | 1 |
| 203147-4 | Rotor | 1 | 867554-8 | Reversing Valve Screw (Reversible Tools only) | 1 |
| 203148-2 | Cylinder (Reversible Tools only) | 1 | 869923-3 | Front Bearing Plate | 1 |
| 203149-0 | Cylinder (Non-Reversible only)(Incl. 812918-1) | 1 | 869925-8 | Rear Bearing Plate (Reversible Tools only) | 1 |
| 203150-8 | Handle (Non-Reversible Tools only) | 1 | 869927-4 | Rotor Blade | 5 |
| 203151-6 | Handle (Reversible Tools only) | 1 | 869928-2 | Rear Bearing Plate (Non-Reversible Tools only) | 1 |
| 615018-1 | "O"-Ring 2-1/2" x 2-5/8" | 4 | 869929-4 | Motor Spacer * | 1 |
| 617510-3 | "O"-Ring 2-1/8" x 2-5/16" (Reversible Tools only) | 1 | 869931-6 | Throttle Valve Seat | 1 |
| 622062-8 | "O"-Ring 7/8" x 1-1/16" | 1 | 869933-2 | Inlet Bushing | 1 |
| 622881-1 | "O"-Ring 15/16" x 1-1/8" | 1 | 869936-5 | Valve Block | 1 |
| 812918-1 | Cylinder Pin | 1 | 869937-3 | Shut-Off Valve (Automatic Shut-off Tools only) | 1 |
| 843656-0 | Air Inlet Screen | 1 | 869938-1 | Trip Rod (Automatic Shut-off Tools only) * | 1 |
| 847234-2 | "O"-Ring 1-1/8" x 1-1/4" (Reversible Tools only) | 1 | 869939-9 | Valve Block (Reversible Tools only) | 1 |
| 847603-8 | Cylinder Alignment Screw (Reversible Tools only) | 1 | 869940-7 | Reversing Valve (Reversible Tools only) | 1 |
| 847960-2 | Set Screw | 1 | 869942-3 | Reversing Ring (Reversible Tools only) | 1 |
| 847528-7 | Rotor Bearing | 2 | 869943-1 | Muffler | 1 |

*Denotes parts not included in Sub-Assemblies listed below.

| COMPLETE SUB-ASSEMBLIES | | |
|-------------------------|--------------------------------------|--------------------------------------|
| | Clecomatic Tools | Stalls Tools |
| Motor Housing | Non-Rev. - 201327-4, Rev. - 201330-8 | Non-Rev. - 201328-2, Rev. - 201329-0 |

RS-2

ORDERING INFORMATION

To place an order or to get more detailed information on any E.H. Wachs products, call us at:
1-800-323-8185.

ORDERING REPLACEMENT PARTS

Please use parts list provided in manual. Have part description and part number of required replacement part or parts to help expedite order and insure proper parts are being ordered.

REPAIR INFORMATION

Please call E.H. Wachs Company prior to returning any equipment for repair. We will advise you of shipping and handling. Please enclose with equipment to be repaired your name, address, phone number and a brief description of problem or work to be done or estimated.

All repair work done at our plant will be estimated and the customer advised of cost and time required to complete repair.

WARRANTY INFORMATION

Enclosed with the manual is a warranty card. Please fill out the registration card and return to E.H. Wachs. Retain the owners registration record and warranty card for your information.

RETURN GOODS ADDRESS

E.H. Wachs Water Utility Products
600 Knightsbridge Parkway
Lincolnshire, Illinois 60069 USA

847-537-8800

FAX: 847-520-1147 • 847-520-1168

Toll-Free: 1-800-323-8185

www.ehwachs.com

| | |
|---|---|
|  | PIPE & VALVE |
| | MAINTENANCE PRODUCTS |
| Mod. | S/N: <input type="text"/> <input type="text"/> <input type="text"/> <input type="text"/> <input type="text"/> <input type="text"/> <input type="text"/> |
| Enter your machine's serial number here for proper record keeping and ordering reference. | |



600 Knightsbridge Parkway • Lincolnshire, IL 60069
847-537-8800 • www.ehwachs.com