



E.H. Wachs
600 Knightsbridge Parkway
Lincolnshire, IL 60069
www.ehwachs.com

MB Plus Boiler Tube Beveler

User's Manual



E.H. Wachs Part No. 71-MAN-03
Rev. B, August 2013

Revision History:
Original December 2009
Rev. A January 2013

Copyright © 2013 E.H. Wachs. All rights reserved.
This manual may not be reproduced in whole or in part
without the written consent of E.H. Wachs.

**EU DECLARATION OF CONFORMITY
WITH
COUNCIL DIRECTIVE 2006/42/EC**

Issue Details:	Date: 1/1/2011	Place: E.H. Wachs, Lincolnshire, IL USA
Directives:	Machinery Safety Directive 2006/42/EC	
Conforming Machinery:	<u>End Prep and Flange Facing Machines:</u> Model TSE, FSE, and TFS Tube and Fitting Squaring Machines. Model SDB 103, SDB 206, and SDB 412 Small Diameter Bevelers; Model FF 206, FF 313, and FF 424 Flange Facers. Model SB, LB, and MB Plus Boiler Tube Bevelers. EP 424 End Prep/Flange Facer.	
Model Number:	18-000-XX (TSE, FSE); 19-000-XX (TFS); 16-000-XX (SDB-103/FF-206); 56-000-XX (SDB-206/FF313); 66-000-XX (SDB-412/FF-424); 70-000-XX (SB); 71-000-XX (MB Plus); 72-000-XX (LB); 81-000-XX (EP 424).	
Serial Number:		
Manufacturer:	E.H. Wachs 600 Knightsbridge Parkway Lincolnshire IL 60069 USA	
Responsible Representative:	Orbitalum Tools GmbH Josef-Schüttler-Str. 17, 78224 Singen Germany Tel. +49 (0) 7731 - 792 872 Fax +49 (0) 7731 - 792 566	
Harmonised Standards & Other Technical Standards/Specifications Applied or Referenced:	EN ISO 12100-1:2003 + A1:2009 EN ISO 12100-2:2003 + A1:2009 EN 60204-1:2006 (for electric machines) EN ISO 13857:2008 EN 982:1996 + A1:2008 (for hydraulic machines) EN 983:1996 (for pneumatic machines) EN 13732-1:2006 EN ISO 14121-1:2007 EN ISO 13850:2008 (for pneumatic machines)	
Provisions with which Conformity is Declared:	Essential Health and Safety Requirements of Annex 1 of the Machinery Directive	
We hereby certify that the machinery described above conforms to the provisions of Council Directive 2006/42/EC on the approximation of the laws of the Member States relating to the safety of machinery.		
Signed:		
Signatory:	Pete Mullally Quality Manager E.H. Wachs	

Table of Contents

Chapter 1: About This Manual	1
Purpose of This Manual	1
How to Use The Manual	2
Symbols and Warnings	2
Manual Updates and Revision Tracking	3
Chapter 2: Safety	5
Operator Safety	5
Safety Symbols	6
Protective Equipment Requirements	7
Safety Labels	7
Chapter 3: Introduction to the Equipment	9
Equipment Description	9
Specifications	14
Operating Envelope	14
Chapter 4: Assembly, Disassembly, and Storage	19
Storage Checklist	20
Chapter 5: Operating Instructions	21
Configuring the MB Plus	21
Selecting and Installing Clamp Legs	21
Changing the Tool Head (Extender Kit)	28
Installing the Tooling	31
Wedge-Lock Tooling	32
Straight-Shank Tooling	33
Setting Up The MB Plus	35
Installing the Machine on the Workpiece	35
Adjusting the Tooling	37
Operating the Machine	39
Removing the Machine from the Workpiece	42
Chapter 6: Routine Maintenance	45
Machine Lubrication	45
Air Motor Lubrication	45
Replace Air Line Filter	46
Chapter 7: Service and Repair	53
Removing and Installing the Drive Motor	53

Air Motor Service	55
0.75 HP Configuration (71-000-04)	55
1.1 HP Configuration (71-000-05)	55
Chapter 8: Parts Lists and Drawings	57
Assembly Drawings	57
MB Plus, 0.75 HP Air Drive Configuration	58
MB Plus, 1.1 HP Air Drive Configuration	59
Drawbar Ratchet Assembly, 71-402-01	60
Feed Housing Assembly, 71-407-00	60
Bearing Housing Assembly, 71-408-00	61
Wedgelock Head Assembly, 71-409-00	62
Mandrel Assembly with Standard Leg Set, 71-410-00	62
Mandrel Assembly with Extended Leg Set, 71-410-01	63
Extended Range (3.0”) Kit, 71-401-00	63
0.75 HP Air Motor Assembly, 71-406-00	64
0.75 HP Air Motor, 71-026-00	65
1.1 HP Air Motor Assembly, 71-404-00	66
1.1 HP Air Motor, 71-060-00	67
ATM Hose (for 0.75 HP Air Drive), 80-4202-00	68
ATM Hose (for 1.1 HP Air Drive), 71-405-00	68
110 V Electric Drive MB Plus (Obsolete), 71-000-06	69
220 V Electric Drive MB Plus (Obsolete), 71-000-07	70
Chapter 9: Accessories and Spare Parts	71
Tooling	71
Accessories	72
Chapter 10: Ordering Information	73
Ordering Replacement Parts	73
Repair Information	73
Warranty Information	74
Return Goods Address	74

Chapter 1

About This Manual

PURPOSE OF THIS MANUAL

This manual explains how to operate and maintain the MB Plus boiler tube beveler. It includes instructions for set-up, operation, and maintenance. It also contains parts lists, diagrams, and service information to help you order replacement parts and perform user-serviceable repairs.

Before operating the MB Plus, you should read through this manual and become familiar with all instructions. At a minimum, make sure you read and understand the following chapters:

- Chapter 1, About This Manual
- Chapter 2, Safety
- Chapter 3, Introduction to the Equipment
- Chapter 5, Operating Instructions
- Chapter 9, Accessories

If you will be performing service or repairs, make sure you read and understand these chapters:

- Chapter 1, About This Manual
- Chapter 4, Assembly and Disassembly
- Chapter 6, Routine Maintenance
- Chapter 7, Service and Repair.

You will also want to refer to Chapter 8, Parts Lists and Drawings.

In This Chapter

PURPOSE OF THIS MANUAL
HOW TO USE THE MANUAL
SYMBOLS AND WARNINGS
MANUAL UPDATES AND
REVISION TRACKING

Throughout this manual, refer to this column for warnings, cautions, and notices with supplementary information.

HOW TO USE THE MANUAL

This manual is organized to help you quickly find the information you need. Each chapter describes a specific topic on using or maintaining your equipment.

Each page is designed with two columns. This large column on the inside of the page contains instructions and illustrations. Use these instructions to operate and maintain the equipment.

The narrower column on the outside contains additional information such as warnings, special notes, and definitions. Refer to it for safety notes and other information.

SYMBOLS AND WARNINGS

The following symbols are used throughout this manual to indicate special notes and warnings. They appear in the outside column of the page, next to the section they refer to. Make sure you understand what each symbol means, and follow all instructions for cautions and warnings.



WARNING

A WARNING alert with the safety alert symbol indicates a potentially hazardous situation that **could** result in **serious injury or death**.



This is the **safety alert symbol**. It is used to alert you to **potential personal injury hazards**. Obey all safety messages that follow this symbol to avoid possible injury or death.



CAUTION

A CAUTION alert with the safety alert symbol indicates a potentially hazardous situation that **could** result in **minor or moderate injury**.

This is the **equipment damage alert symbol**. It is used to alert you to **potential equipment damage situations**. Obey all messages that follow this symbol to avoid damaging the equipment or workpiece on which it is operating.



CAUTION

A CAUTION alert with the damage alert symbol indicates a situation that **will** result in **damage to the equipment**.



IMPORTANT

An IMPORTANT alert with the damage alert symbol indicates a situation that **may** result in **damage to the equipment**.

NOTE

This symbol indicates a user note. **Notes** provide additional information to supplement the instructions, or tips for easier operation.



NOTE

A NOTE provides supplementary information or operating tips.

MANUAL UPDATES AND REVISION TRACKING

Occasionally, we will update manuals with improved operation or maintenance procedures, or with corrections if necessary. When a manual is revised, we will update the revision history on the title page.

You may have factory service or upgrades performed on the equipment. If this service changes any technical data or operation and maintenance procedures, we will include a revised manual when we return the equipment to you.

Current versions of E.H. Wachs Company manuals are also available in PDF format. You can request an electronic copy of this manual by emailing customer service at sales@wachSCO.com.



Chapter 2

Safety

The E.H. Wachs Company takes great pride in designing and manufacturing safe, high-quality products. We make user safety a top priority in the design of all our products.

Read this chapter carefully before operating the MB Plus. It contains important safety instructions and recommendations.

OPERATOR SAFETY

Follow these guidelines for safe operation of the equipment.

- **READ THE OPERATING MANUAL.** Make sure you understand all setup and operating instructions before you begin.
- **INSPECT MACHINE AND ACCESSORIES.** Before starting the machine, look for loose bolts or nuts, leaking lubricant, rusted components, and any other physical conditions that may affect operation. Properly maintaining the machine can greatly decrease the chances for injury.
- **ALWAYS READ PLACARDS AND LABELS.** Make sure all placards, labels, and stickers are clearly legible and in good condition. You can purchase replacement labels from E.H. Wachs Company.
- **KEEP CLEAR OF MOVING PARTS.** Keep hands, arms, and fingers clear of all rotating or moving parts.

In This Chapter

OPERATOR SAFETY

SAFETY LABELS



Look for this symbol throughout the manual. It indicates a personal injury hazard.

Always turn machine off before doing any adjustments or service.

- **SECURE LOOSE CLOTHING AND JEWELRY.** Secure or remove loose-fitting clothing and jewelry, and securely bind long hair, to prevent them from getting caught in moving parts of the machine.
- **KEEP WORK AREA CLEAR.** Keep all clutter and nonessential materials out of the work area. Only people directly involved with the work being performed should have access to the area.

Safety Symbols



This icon is displayed with any safety alert that indicates a personal injury hazard.

WARNING

This safety alert indicates a potentially hazardous situation that, if not avoided, **could** result in **death or serious injury**.

CAUTION

This safety alert, with the personal injury hazard symbol, indicates a potentially hazardous situation that, if not avoided, **could** result in **minor or moderate injury**.

Protective Equipment Requirements

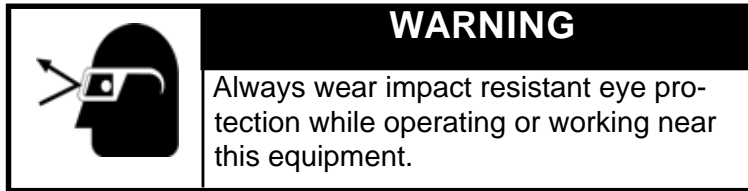

For additional information on eye and face protection, refer to Federal OSHA regulations, 29 Code of Federal Regulations, Section 1910.133., Eye and Face Protection and American National Standards Institute, ANSI Z87.1, Occupational and Educational Eye and Face Protection. Z87.1 is available from the American National Standards Institute, Inc., 1430 Broadway, New York, NY 10018.

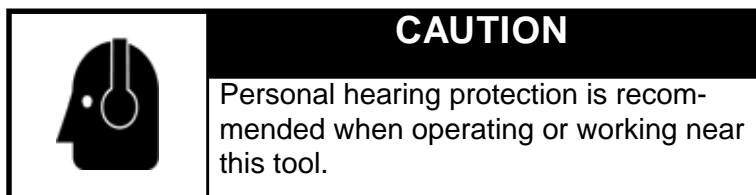

Hearing protectors are required in high noise areas, 85 dBA or greater. The operation of other tools and equipment in the area, reflective surfaces, process noises, and resonant structures can increase the noise level in the area. For additional information on hearing protection, refer to Federal OSHA regulations, 29 Code of Federal Regulations, Section 1910.95, Occupational Noise Exposure and ANSI S12.6 Hearing Protectors.

SAFETY LABELS

The safety label in Figure 2-1 is on the MB Plus machine. The safety label on the air motor is shown in Figure 2-2. If any label is removed or damaged, order a replacement. See Chapter 10 for ordering information.



Figure 2-1. This Warning label (part number 71-062-00) is on the MB Plus machine.



Figure 2-2. The safety Caution label (part number 90-401-03) is on the air motor.



Figure 2-3. The air pressure Caution label (part number 90-401-02) is on the air motor.

Chapter 3

Introduction to the Equipment

.....

The MB Plus is an I.D. (inside diameter) mounted beveling machine for prepping boiler tubes. The MB Plus is an improved version of the Wachs MB boiler tube beveler; it features larger bearings and hardened components for better durability, while maintaining the high performance, convenient setup, and easy operation of the full line of Wachs beveling machines.

EQUIPMENT DESCRIPTION

The MB Plus features the following components:

- a machine body with gearbox, feed mechanism, and drive adapter
- a self-centering mandrel with drawbar and ratcheting clamp handle
- multiple clamp leg sets for I.D. mounting on the full range of tube sizes
- a rotating tool head
- a ratcheting feed handle
- 0.75 or 1.1 HP pneumatic drive motor.

Figure 3-1 illustrates the components of the MB Plus. Figure 3-2 shows the tool head and tool mounting slots.

In This Chapter

EQUIPMENT DESCRIPTION
SPECIFICATIONS
OPERATING ENVELOPE

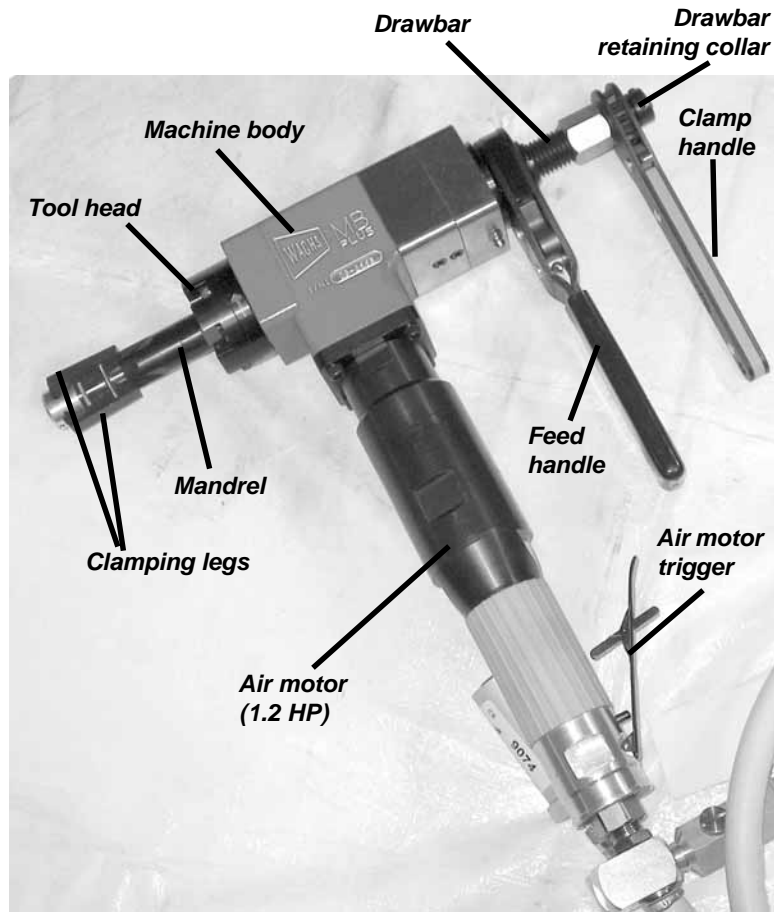

Figure 3-1. The photo shows the MB Plus configuration with the 1.1 HP motor (71-000-05).

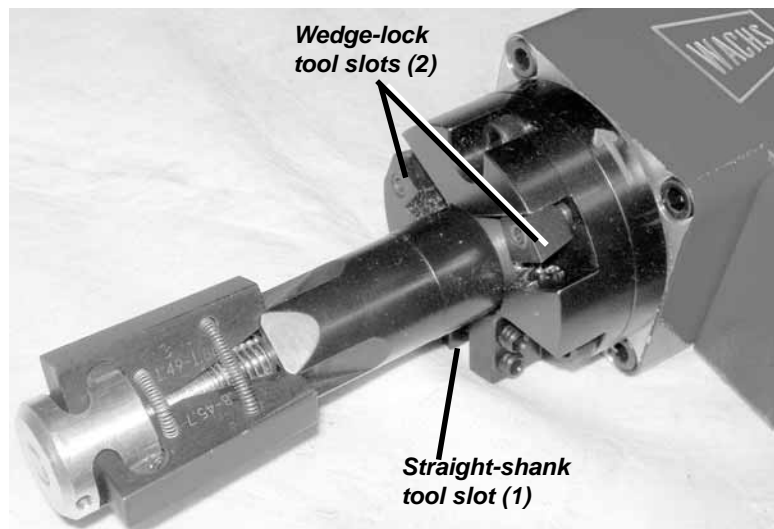

Figure 3-2. The photo shows the tool mounting slots on the standard tool head.

The standard configuration of the machine (model 71-000-04) uses a 0.75 HP air motor drive. An optional 1.1 HP air motor drive configuration (71-000-05) is available.

Two electric drive configurations (110 V, 71-000-06; and 220 V, 71-000-07) are obsolete. Assembly drawings for these configurations are in Chapter 8 for ordering replacement parts.

Figure 3-3 and Figure 3-4 show standard clamp legs provided with the MB Plus. Each leg set is assembled on springs to keep them connected and to make installation and clamping easy. The clamp legs are stamped with the size range of the pipe or tube I.D. they fit.

Figure 3-5 shows the optional extender kit, with 3 larger sets of clamp legs and a larger tool head. The extender kit allows the MB Plus to be mounted on pipe I.D. up to 3.0", and to machine up to 3.25" O.D.

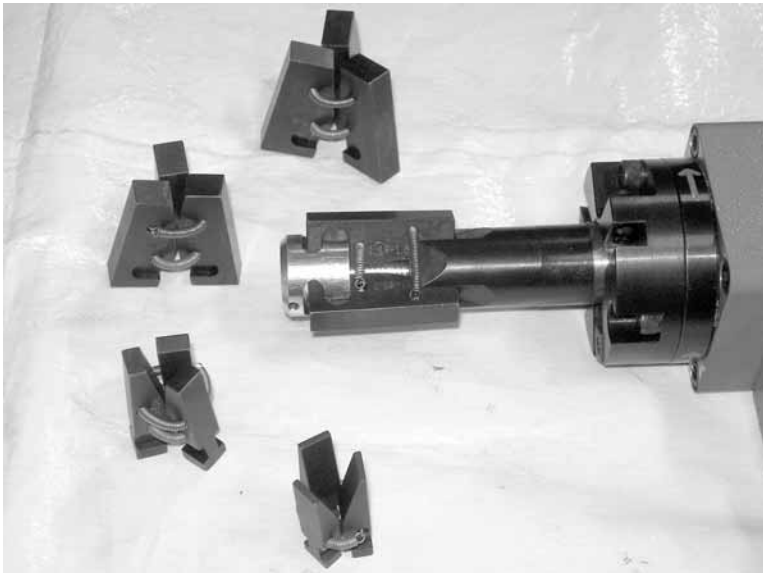

Figure 3-3. Five standard clamp leg sets are supplied with the MB Plus, covering an I.D. range from 1.0" to 2.3" (25.4 to 58.4 mm).

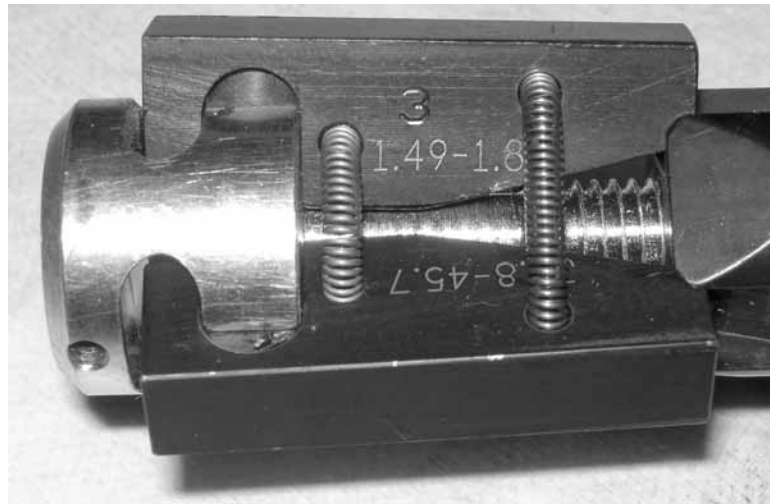

Figure 3-4. Each clamp leg has its I.D. range stamped on it (inches on one side and millimeters on the other side).



Figure 3-5. An optional extender kit includes a larger tool head and 3 leg sets for I.D. up to 3.0" (76.2 mm) and O.D. up to 3.25" (82.6 mm).

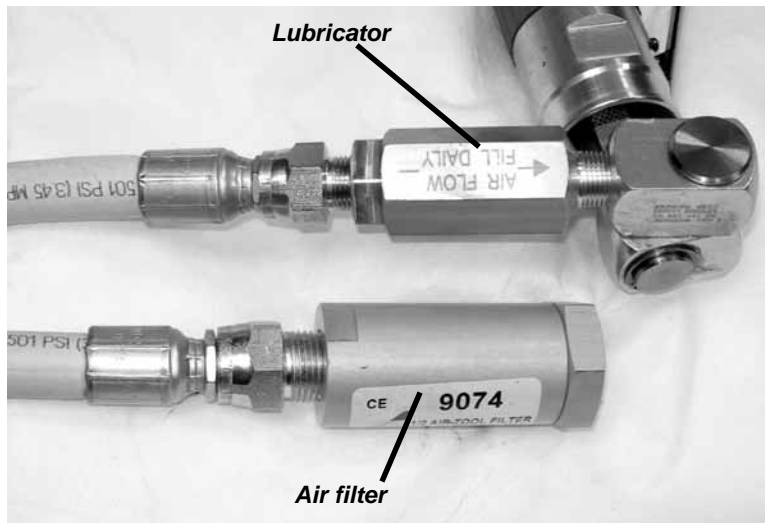

Figure 3-6. The air hose connection has a built-in air filter to keep the air motor clean, and a lubricator to oil the motor.



Figure 3-7. A hex wrench cluster and 1/8" short-arm hex wrench are provided for operation and maintenance of the MB Plus.

SPECIFICATIONS

Table 1: MB Plus Specifications

Feature	Specification
I.D. Range	Standard: 1.00" to 2.30" (25.4 to 58.4 mm)
	Extended: up to 3.0" (76.2 mm)
O.D. Range	Standard: 1.25" to 2.50" (31.8 to 63.5 mm)
	Extended: up to 3.25" (82.6 mm)
Feed Rate	0.111" (2.8 mm) per handle revolution
Max. Wall Thickness	0.63" (16.0 mm)—tooling dependent
Power Requirements	Air supply: 31 cfm @ 90 psi (71-000-04); 35 cfm @ 90 psi (71-000-05)
Tooling	Standard Wachs beveler tooling; wedge-lock and straight-shank tool designs
Dimensions (H x W x L)	<u>71-000-04</u> : 10.28" X 2.5" X 15.5" (261 x 64 x 394 mm) <u>71-000-05</u> : 14.25" X 2.5" X 15.5" (362 x 64 x 394 mm)
Operating Weight (with drive motor)	71-000-04: 18.6 lbs (8.4 kg) 71-000-05: 23.2 lbs (10.5 kg)

OPERATING ENVELOPE

The drawings on the following pages illustrate the operating envelopes for both drive configurations of the MB Plus.

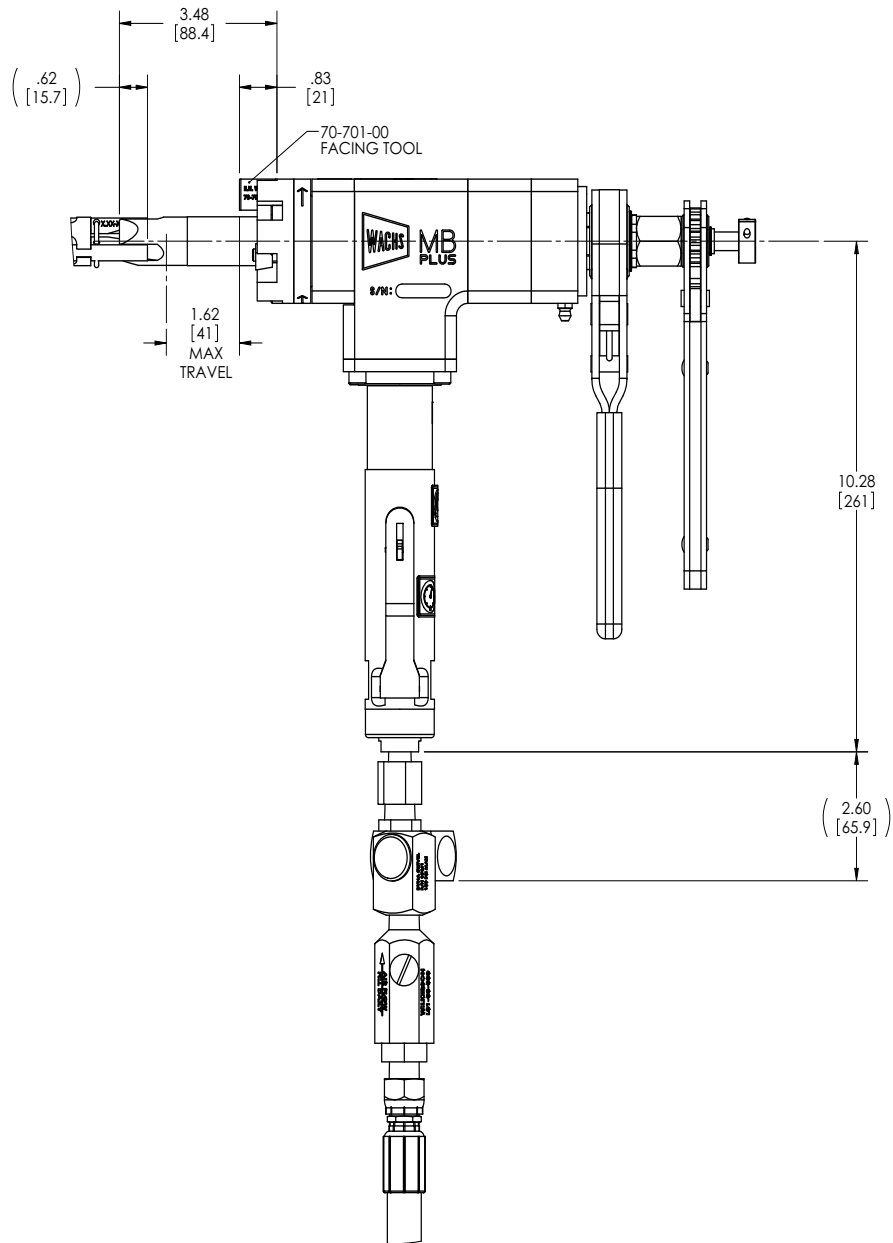
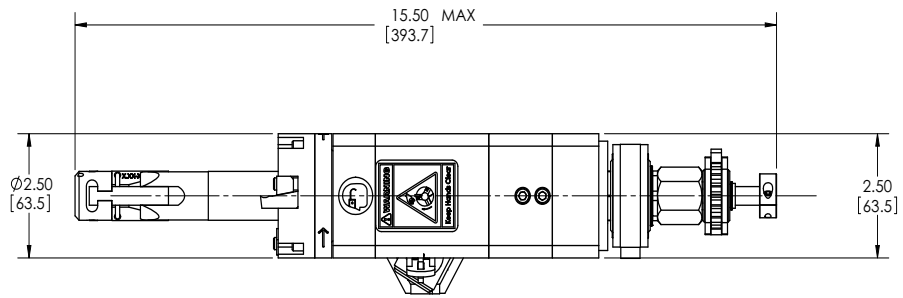

Operating envelope for standard (0.75 HP) air drive configuration (71-000-04).

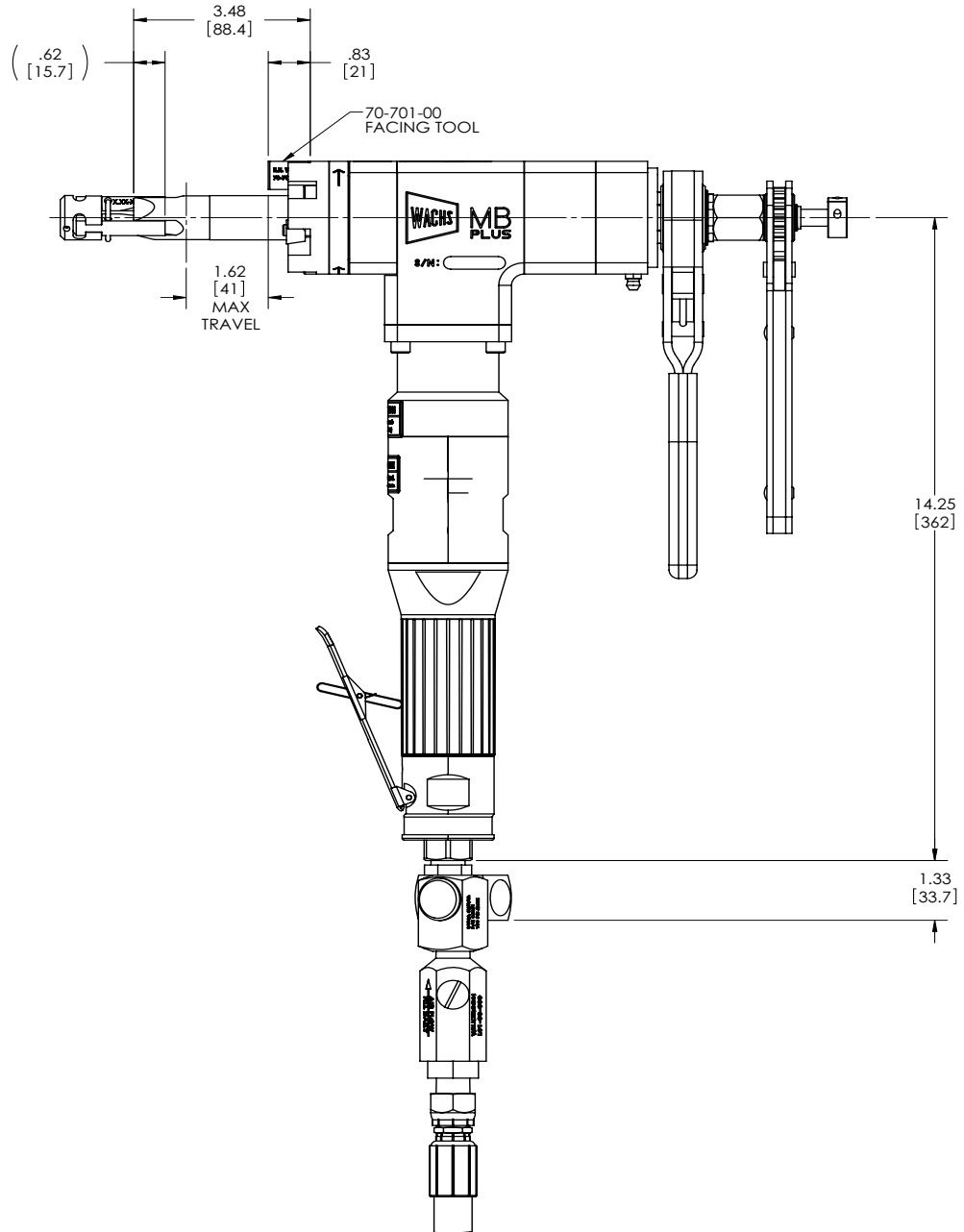
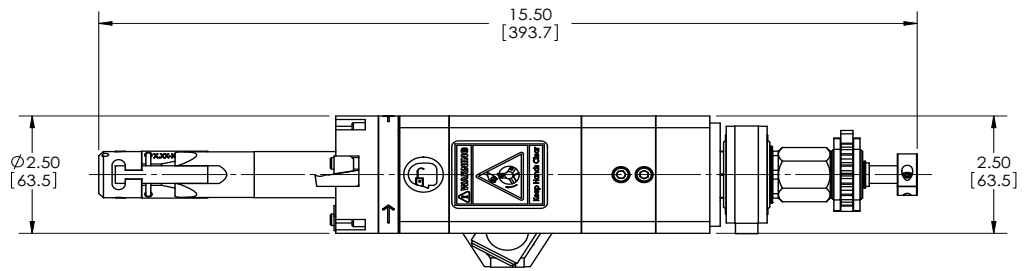

Operating envelope for 1.1 HP air drive configuration (71-000-05).

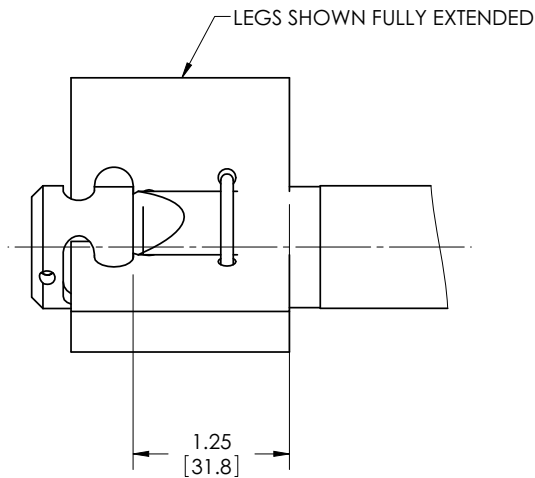
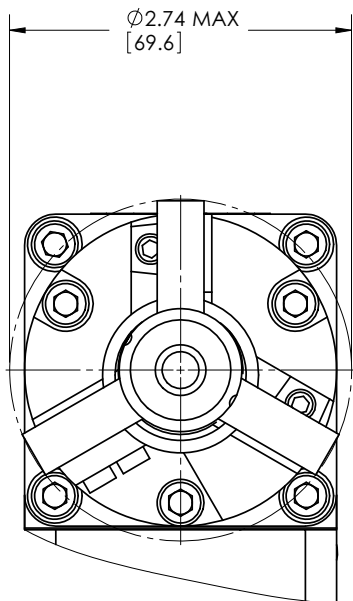

SCALE: 1:1

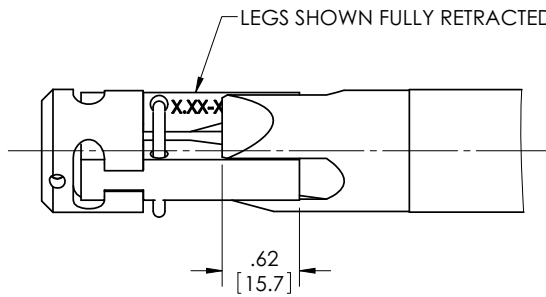
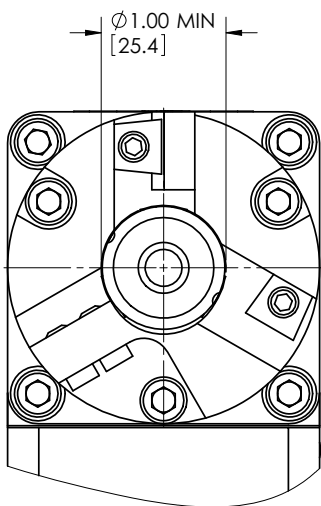

SCALE: 1:1

Operating envelope for standard leg sets (all configurations).

Chapter 4

Assembly, Disassembly, and Storage

The MB Plus is shipped fully assembled and ready for use. The only assembly steps typically required are installing the clamping legs and tooling. These procedures are described in the operating instructions in Chapter 5.

The machine is shipped and stored in a durable, customized storage case, as shown in Figure 4-1. The case includes compartments for clamping legs, hand tools, tooling, and accessories.



Figure 4-1. Store the MB Plus and its accessories in the case provided. Compartments are provided for all standard and optional components.

In This Chapter

STORAGE CHECKLIST

 **NOTE**

You do not need to remove the drive motor for storing the machine.

Keep the machine stored in its case when not using it. Always use the case when shipping the MB Plus. The case includes a padlock slot for secure storage and shipping.

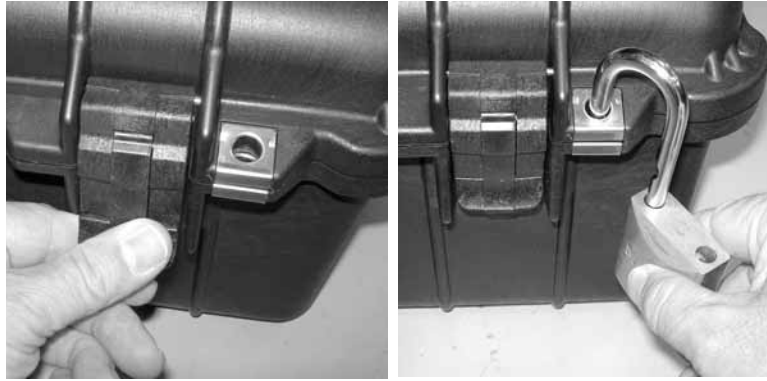

Figure 4-2. Press the latches down securely to snap them closed. If necessary, you can use a padlock to secure the machine in its case.

STORAGE CHECKLIST

Before storing the MB Plus, perform the following maintenance steps. If you are using the machine in an especially dirty or corrosive environment, perform these steps frequently.

- Clean the machine by wiping off dirt, debris, and accumulated oil or grease.
- Put oil in the air motor oiler, and operate the motor for a few seconds to lubricate its internal components.
- Lubricate the machine according to the instructions in Chapter 6.
- Spray or wipe a light coating of anti-corrosion lubricant on non-finished, non-painted surfaces.
- Put the machine in its storage case, with all components stored in their compartments.
- If possible, keep the storage case indoors and away from moisture.
- If you will be storing the machine longer than 30 days, put desiccant packets in the case to prevent corrosion.

Chapter 5

Operating Instructions

CONFIGURING THE MB PLUS

Before you install the MB Plus on the workpiece, set it up with the required clamp legs (and tool head, if you have the optional extender kit).

Selecting and Installing Clamp Legs

There are 5 standard sets of clamp legs provided with the MB Plus. Table 1 lists the clamp leg sets and their I.D. ranges.

Table 1: Standard Clamp Leg Sets

Part No.	Minimum I.D.	Maximum I. D.	Recommended Tube I.D. Range
71-400-01	1.00" (25.4 mm)	1.32" (33.5 mm)	1.00"-1.28" (25.4-32.6 mm)
71-400-02	1.25" (31.2 mm)	1.56" (39.6 mm)	1.29"-1.52" (32.7-38.7 mm)
71-400-03	1.49" (37.8 mm)	1.80" (45.7 mm)	1.53"-1.76" (38.8-44.8 mm)
71-400-04	1.73" (43.9 mm)	2.05" (52.1 mm)	1.77"-2.01" (44.9-51.0 mm)
71-400-05	1.98" (50.3 mm)	2.30" (58.4 mm)	2.02"-2.30" (51.1-58.4 mm)

The optional extender kit has 3 additional sets of clamp legs. Table 2 describes the extender kit clamp legs.

In This Chapter

CONFIGURING THE MB PLUS
 SETTING UP THE MB PLUS
 OPERATING THE MACHINE
 REMOVING THE MACHINE
 FROM THE WORKPIECE

Table 2: Extender Kit Clamp Leg Sets

Part No.	Minimum I.D.	Maximum I. D.	Recommended Tube I.D. Range
71-400-06	2.22" (56.4 mm)	2.55" (64.8 mm)	2.26"-2.51" (57.4-63.9 mm)
71-400-07	2.47" (62.7 mm)	2.79" (70.9 mm)	2.52"-2.75" (64.0-70.0 mm)
71-400-08	2.72" (69.1 mm)	3.04" (77.2 mm)	2.76"-3.04" (70.1-77.2 mm)

The following procedure describes how to remove the drawbar from the MB Plus and install the clamp legs.

1. Measure the I.D. of the pipe or tube you are machining.
2. Using the tables above, select the clamp leg set that fits the I.D. of the pipe or tube.
3. Using a 3/32" hex wrench, loosen the screw in the drawbar retainer collar. Unscrew the collar to remove it from the drawbar.



NOTE

Refer to the "Recommended Tube I.D. Range" column for pipes or tubes that are in the "overlap" range between clamp leg sets.

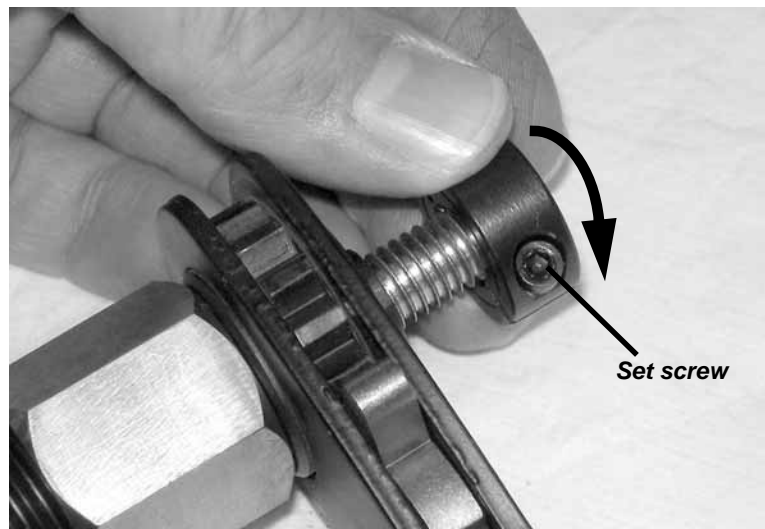

Figure 5-1. Loosen the set screw in the drawbar retaining collar, then turn the collar off the end of the drawbar.

4. Press the ratchet knob on the clamping ratchet to set the ratchet in the release direction.

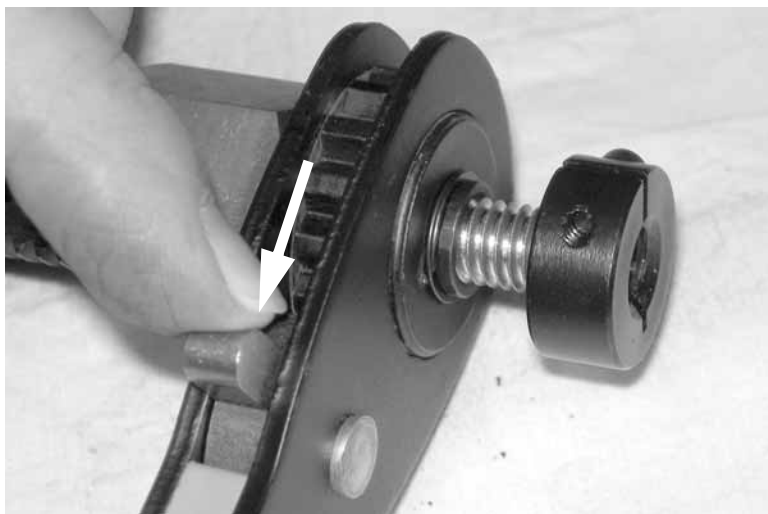

Figure 5-2. Push the clamp ratchet knob as shown to operate the ratchet in the “unclamping” direction.

5. Operate the clamping ratchet handle to extend the drawbar out all the way until you can remove it from the machine.

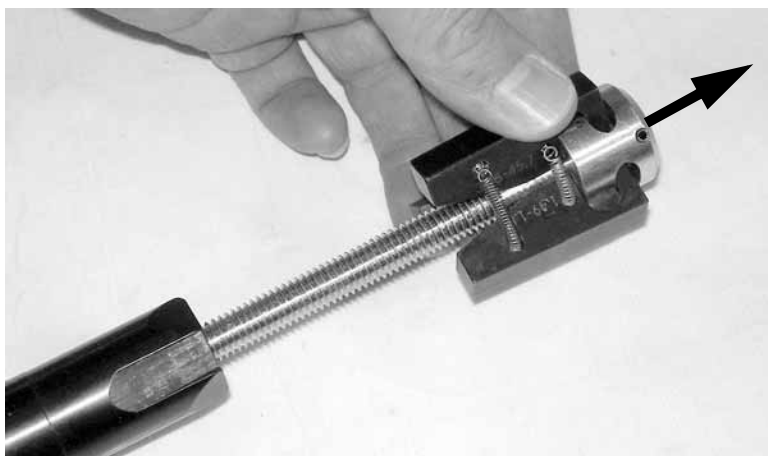

Figure 5-3. Pull the drawbar out of the mandrel

6. To remove the clamp legs currently installed, pull the notches of the legs out of their slots in the drawplate. Slide the leg assembly down the drawbar to remove it.

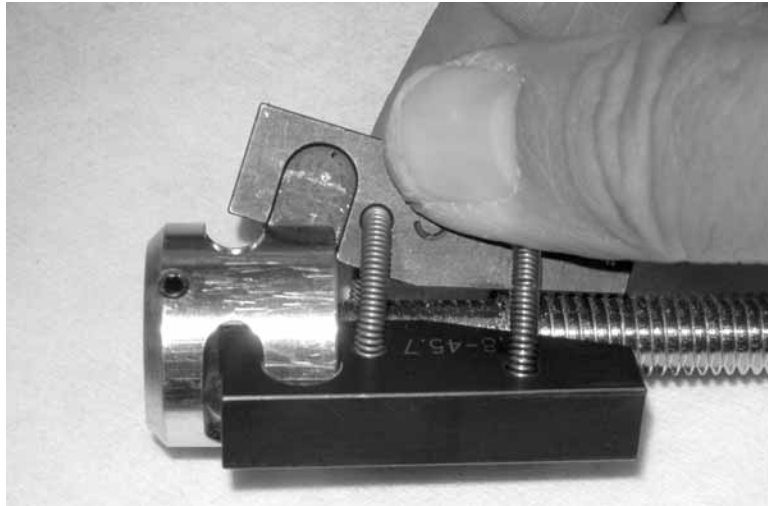

Figure 5-4. Pull the clamp legs up out of the drawplate to remove them.

- 7.** Slide the new leg assembly up the drawbar, with the notched ends of the legs first.

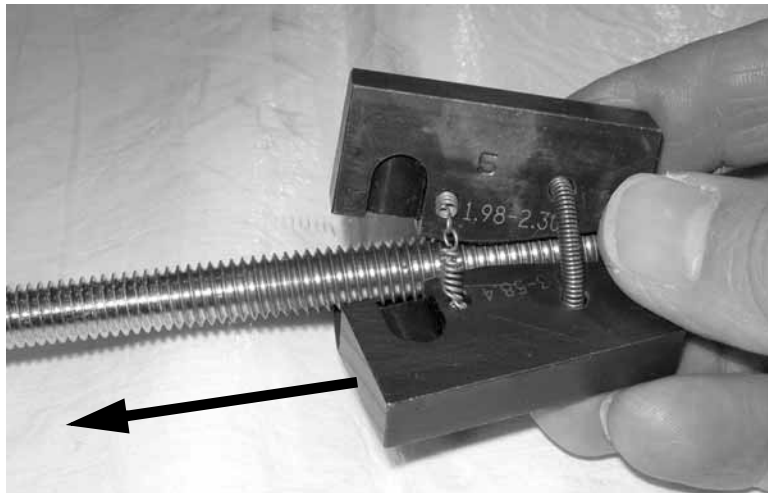

Figure 5-5. Slide the new set of clamp legs up the drawbar, with the notched ends of the legs toward the drawplate.

- 8.** Pull the legs up over the drawplate to engage the leg notches and hold the leg assembly in place.

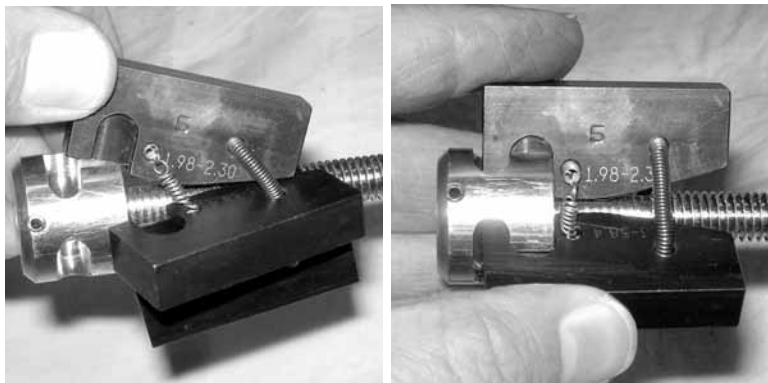

Figure 5-6. Lift the ends of the clamp legs onto the drawplate, and slide the notches into place to secure the legs.

9. Re-insert the drawbar into the machine through the mandrel.

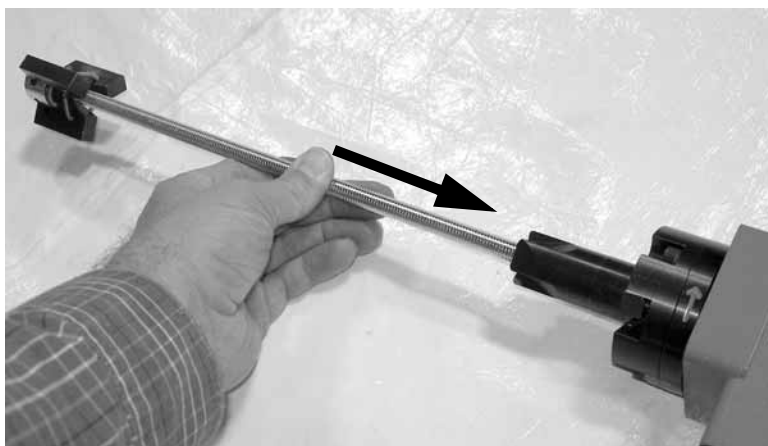

Figure 5-7. Re-install the drawbar through the mandrel.

10. Move the ratchet knob on the clamping ratchet to set the ratchet in the clamping direction.

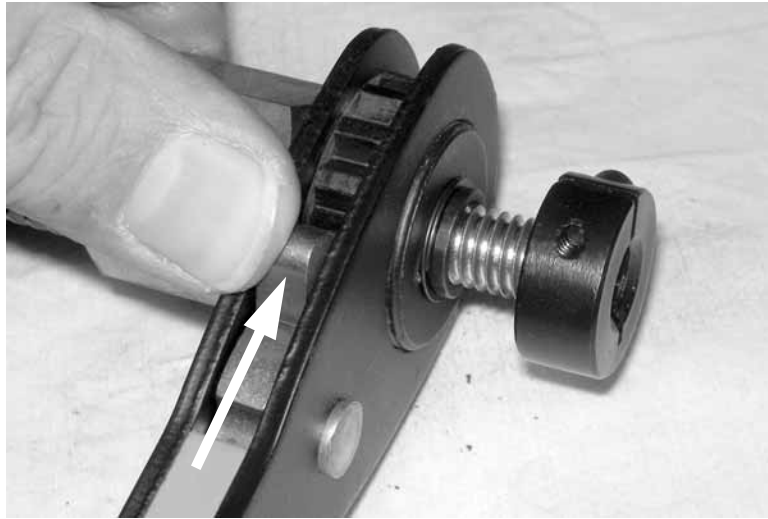

Figure 5-8. Push the knob as shown to set the clamping ratchet to the clamping direction.

- 11.** Push the drawbar into the machine until it stops. Turn it as shown in Figure 5-9 to thread the drawbar into the machine.

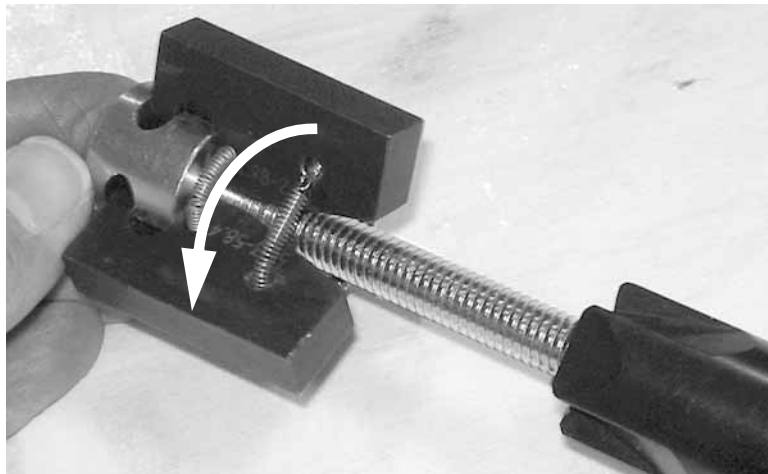

Figure 5-9. While pushing in on the drawbar, turn it to thread it into the machine. Screw it all the way in.

- 12.** When the clamp legs reach the end of the mandrel, turn the drawbar to line the legs up with the slots in the mandrel.

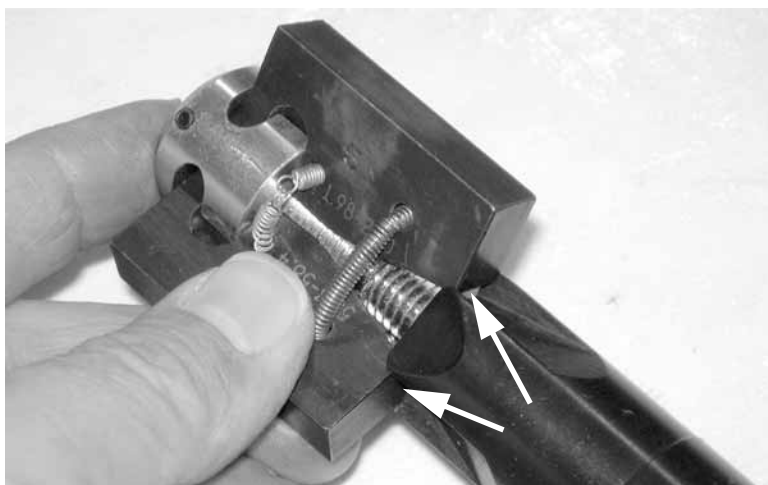

Figure 5-10. Line up the clamp legs with the slots in the end of the mandrel.

- 13.** Operate the clamping ratchet until the legs are engaged in the slots. Do not clamp the legs any farther until you install the machine in the tube.

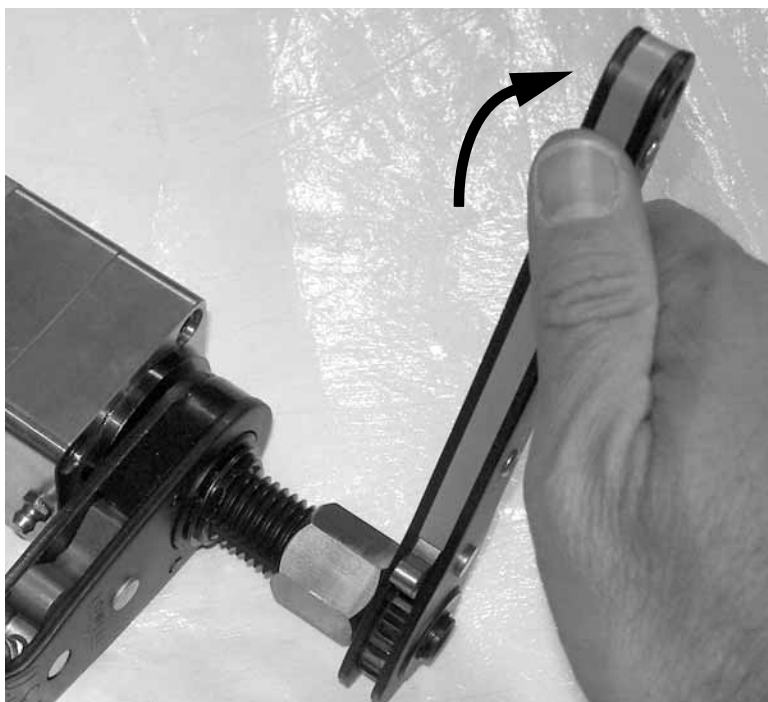

Figure 5-11. Operate the clamping lever to draw the clamp legs into the mandrel.

- 14.** Re-install the retaining collar on the end of the draw-bar and tighten the set screw to secure it.

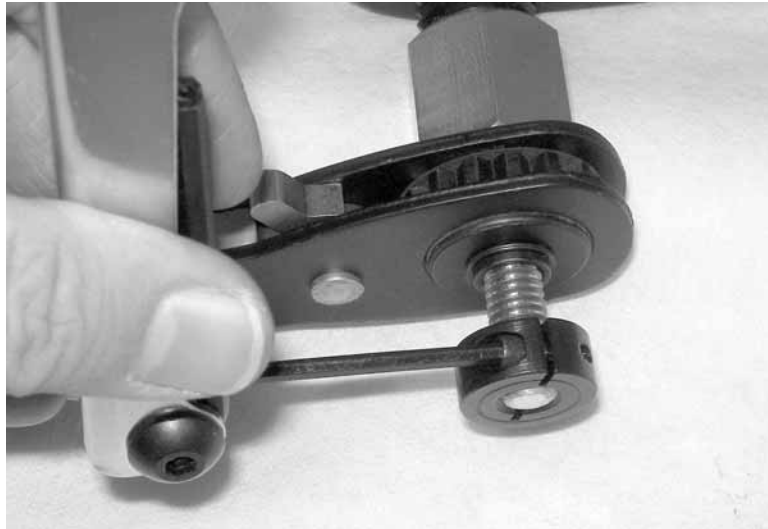

Figure 5-12. Replace the drawbar retaining collar and tighten the set screw to secure it.

Changing the Tool Head (Extender Kit)

If you will be installing the MB Plus on pipe or tube with an O.D. larger than 3.00" (76.2 mm), install the larger tool head included with the extender kit.

Follow the same procedure to remove the larger tool head and replace the standard head.

- 1.** Remove the drawbar as described above in "Selecting and Installing Clamp Legs".
- 2.** Using a 3/16" hex wrench, remove the 3 screws holding the tool head to the main shaft.

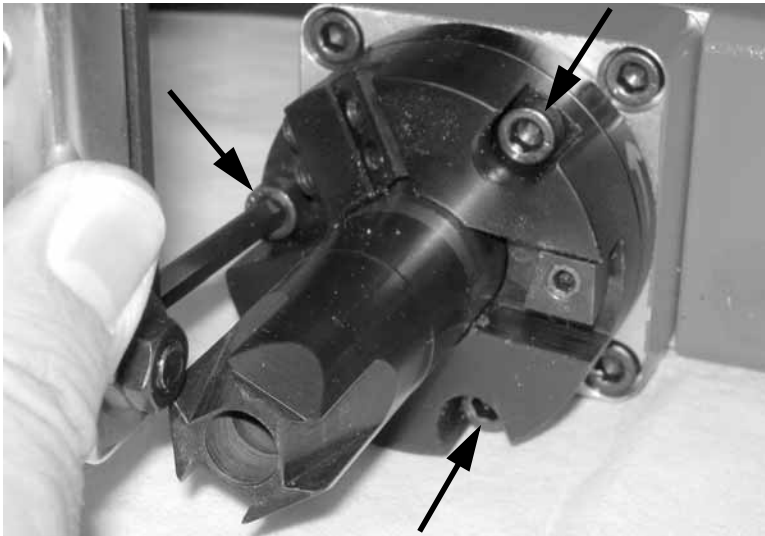

Figure 5-13. Remove the 3 screws holding the tool head.

- 3.** If you need to hold the tool head to keep it from rotating while you loosen the screws, use a screwdriver in the straight shank tool slot, or clamp the tool head gently in a soft-jaw vise.



Figure 5-14. To keep the tool head from turning while loosening the screws, you can insert a screwdriver in the straight shank tool slot.

- 4.** Pull the tool head off the end of the mandrel.

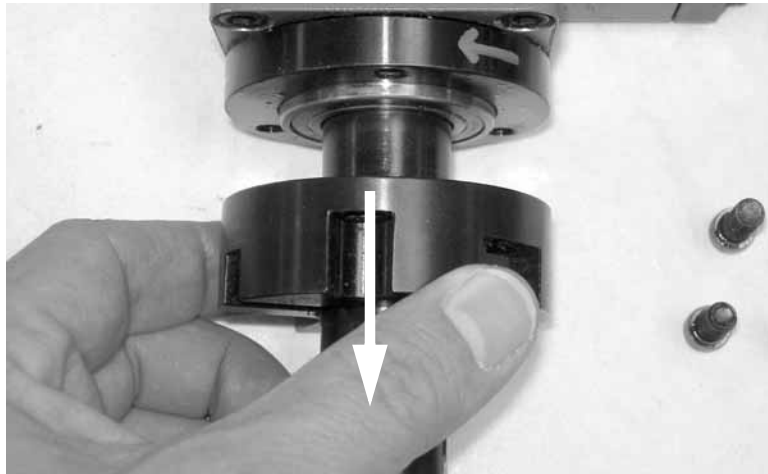

Figure 5-15. Pull the tool head off the mandrel.

- 5.** Slide the larger tool head over the mandrel and align the holes in the head and the main shaft.



Figure 5-16. Slide the large tool head onto the mandrel. Line up the holes in the tool head and the main shaft.

- 6.** Insert and tighten the 3 screws to secure the tool head.



Figure 5-17. Install and tighten the 3 screws holding the tool head.

7. Replace the drawbar through the mandrel and install it according to the instructions in “Selecting and Installing Clamp Legs” above.

Installing the Tooling

It is easiest to install the tooling on the MB Plus before setting up the machine on the workpiece.

There are 2 wedge-lock slots in the tool head. You can install any combination of bevel, facing, and counterbore tooling.

There is also a 1/4” straight-shank tool slot in the tool head. You can install any standard Wachs 1/4” end prep tooling in this slot.



NOTE

The wedge-lock tooling is designed so that it can only be installed in the correct direction. The etched arrows in the main shaft show the direction of rotation.

Wedge-Lock Tooling

1. Slide the base of the selected tool beneath the wedge in the slot. If the tool will not fit, loosen the wedge-lock screw using a 3/32" hex wrench.

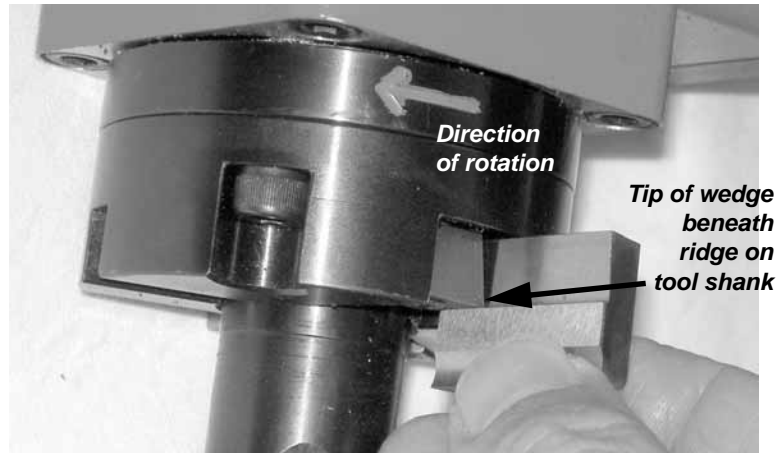

Figure 5-18. Slide the tool into the wedge-lock slot on the tool head. Make sure the tip of the wedge fits up against the ridge in the side of the tool, as indicated.

2. Using a 3/32" hex wrench, tighten down the wedge to hold the tool in place.



Figure 5-19. Tighten the wedge screw to secure the tool.

3. If you are installing a second tool (such as a beveling tool for a facing/bevel operation), slide it into the

other wedge-lock slot and tighten the wedge screw to hold it.

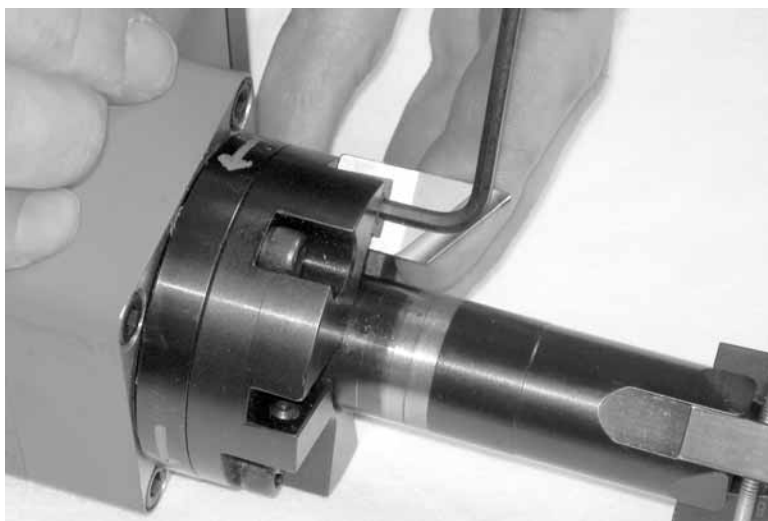

Figure 5-20. The photo shows the installation of a beveling tool.

Straight-Shank Tooling

You can install one straight-shank tool in the MB Plus tool head (standard or extended head). You can use both wedge-lock and straight-shank tooling in the same operation.

1. Using the 3/32" hex wrench, loosen the set screws in the straight-shank tool slot.

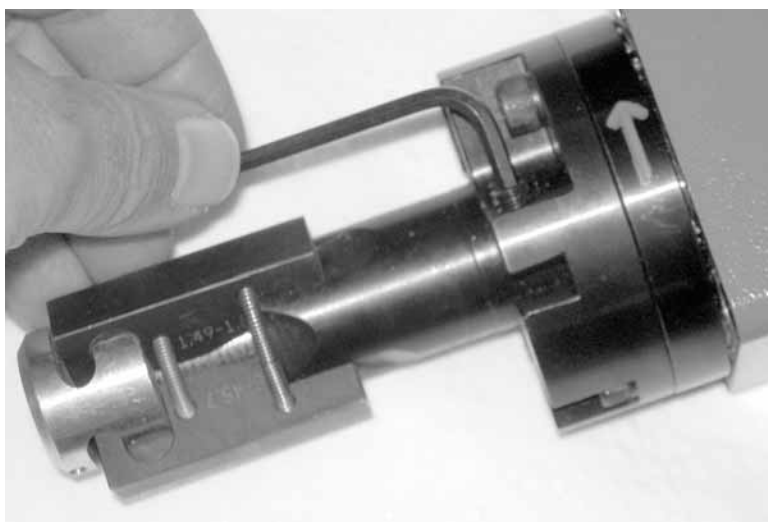

Figure 5-21. Loosen the set screws in the straight-shank slot to allow the tool to be inserted.

2. Insert the tool in the slot, with the cutting edge in the direction of rotation.

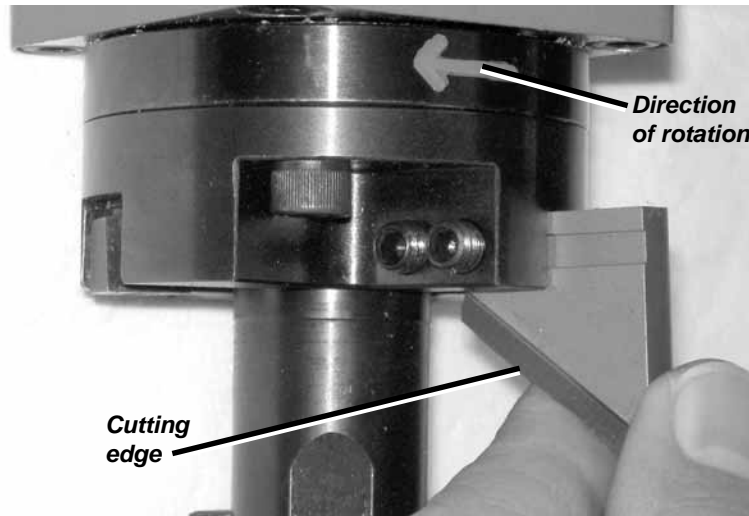

Figure 5-22. Insert the tool in the straight-shank tool slot, with the cutting edge in the direction of rotation.

3. Tighten the set screws to secure the straight-shank tool.



Figure 5-23. Tighten both set screws to secure the tool.



IMPORTANT

The tool must be inserted far enough into the slot so that both set screws contact it. The tool may shift under load if only one screw is holding it. If you need the tool further out for a larger I.D. tube, use the extended tool head.

SETTING UP THE MB PLUS

Installing the Machine on the Workpiece

- Make sure the clamp legs are firmly seated in the draw-plate and are engaged in the mandrel.
 - Make sure the tooling is securely tightened in the tool slots.
 - Make sure the power source is disabled—compressed air turned off at source.
1. Lift the machine into position and insert the clamp legs into the end of the tube or pipe.



Figure 5-24. Insert the clamp legs into the end of the tube or pipe.

2. Position the clamp legs so that they are 1/2”-3/4” (12-19 mm) from the end of the tube.



Figure 5-25. Hold the MB Plus in place with the legs 1/2"-3/4" (12-19 mm) inside the tube end.

- 3.** Set the knob on the clamp handle to the clamping direction.

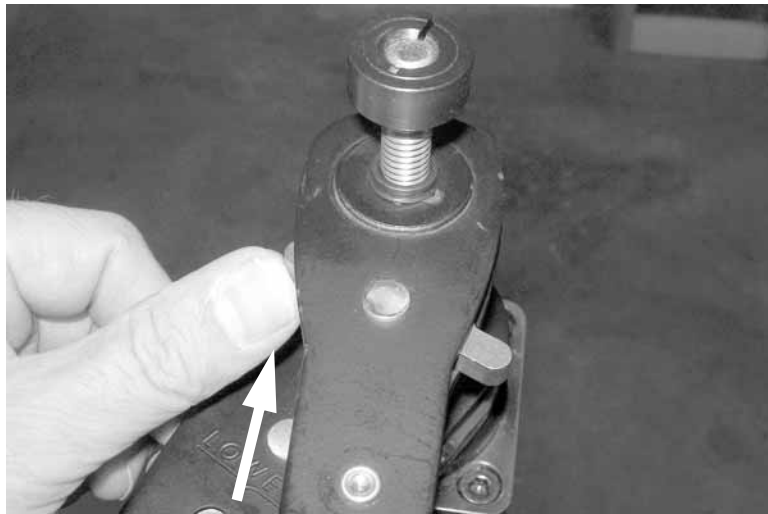

Figure 5-26. Set the knob on the clamp handle to the clamping direction. The clamp handle will engage clockwise to clamp the legs in the tube.

- 4.** Operate the clamp handle to expand the clamp legs against the I.D. of the tube.



Figure 5-27. Turn the clamp handle to tighten the clamp legs in the tube.

5. When the clamp legs get snug, check that they are still 1/2"-3/4" (12-19 mm) from the end of the tube. (Clamping the legs draws them toward the machine, out of the tube.) If necessary, push the legs farther into the tube.
6. Operate the clamp handle to securely tighten the legs. Do not overtighten—firm pressure with one hand is enough to secure the machine.

Adjusting the Tooling

You may need to adjust the position of the tools in the tool slots to align them with the surface of the tube or pipe.

1. Set the knob on the feed handle to the feed direction.



IMPORTANT

Overtightening the clamp handle can damage or break the drawbar.



CAUTION

Turn off the air supply at its source before adjusting the tooling.

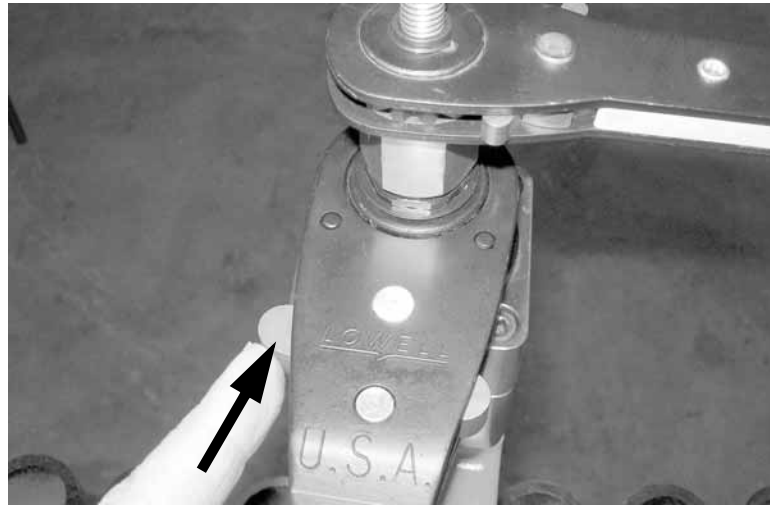

Figure 5-28. Push the knob on the feed handle to the feed forward direction. The handle will engage clockwise to feed the tool head toward the tube end.

- 2.** Operate the feed handle to advance the tools close to the tube/pipe face.



Figure 5-29. Turn the feed handle clockwise to feed the tool head.

- 3.** Check the radial positions of the tools to make sure they will contact the full width of the tube/pipe face.

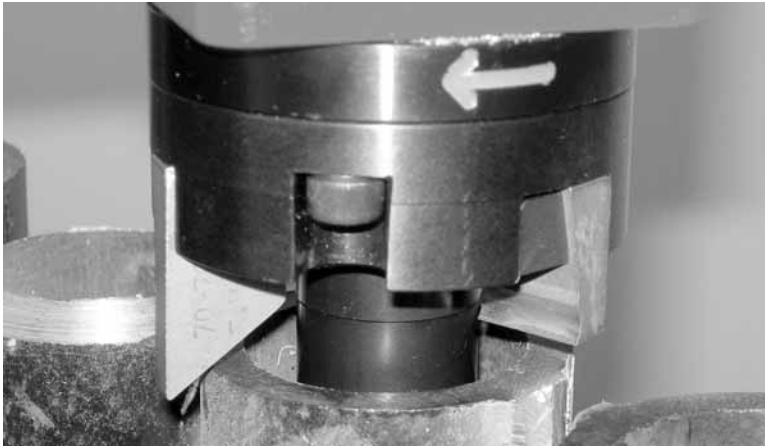

Figure 5-30. Check that the tools are positioned so that they contact the full width of the tube face.

4. If necessary, adjust the tools by loosening the wedge screw (or the straight-shank set screws), and moving the tool in or out until it is positioned fully over the tube/pipe face. Re-tighten the screws.

OPERATING THE MACHINE

1. Connect the compressed air supply line to the drive motor.
2. If using an air drive, turn on the air supply at the source.
3. Make sure the direction knob on the feed handle is set to the feed direction.



IMPORTANT

Make sure the air motor lubricator has oil before operating the machine. See “Air Motor Lubrication” in Chapter 6.

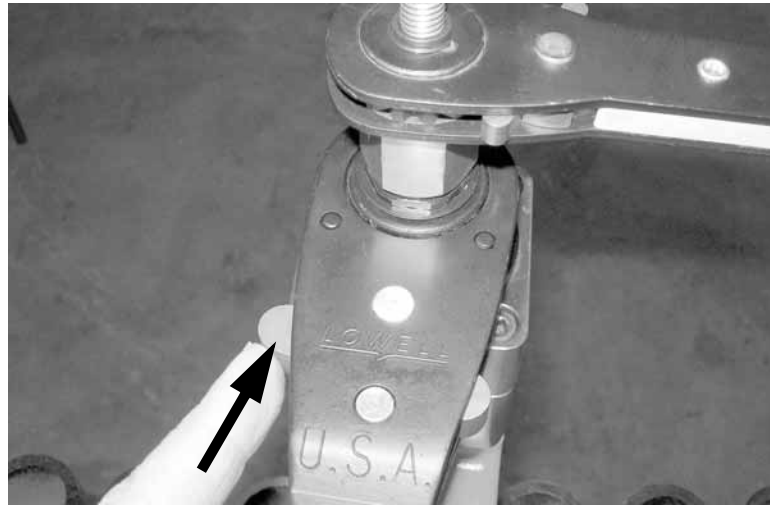

Figure 5-31. Push the knob on the feed handle to the feed forward direction. The handle will engage clockwise to feed the tool head.

4. Release the air motor safety lever and squeeze the trigger to start the motor. The tool head will start to rotate.
5. Adjust the rotating speed by squeezing more or less tightly on the air motor trigger.

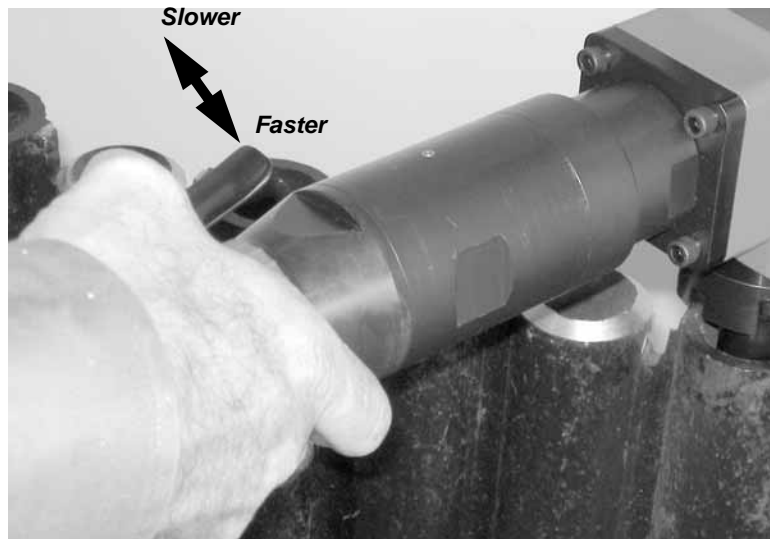

Figure 5-32. Depress the air motor trigger to start the machine. Use the trigger to control the rotating speed.

6. While holding the air trigger, operate the feed lever to feed the tooling into the tube face.



Figure 5-33. Feed the tool head into the workpiece using the feed handle.

7. While cutting, apply continuous and consistent pressure to the feed handle. Adjust pressure as necessary for a smooth surface.



Figure 5-34. Apply continuous feed pressure for a smooth surface.

8. If you need to adjust the position of the tooling during cutting, reverse the direction of the feed handle and retract the tool head away from the tube face. Keep the drive motor running until the tool no longer contacts the tube. Adjust the tooling as required, set the feed direction back to forward, and continue cutting.

9. Continue until you have machined the desired end prep on the tube. With the drive motor still running, reverse the feed handle and retract the tool head.
10. If you need to perform another operation on the tube (such as counterboring), install the required tooling and repeat the operating procedure.

REMOVING THE MACHINE FROM THE WORKPIECE

1. Disconnect the air line from the air motor.
2. Set the knob on the clamp handle to the release direction.



Figure 5-35. Set the knob on the clamp handle to the release direction.

3. Hold the MB Plus securely, and operate the clamp handle to release the clamp legs.



Figure 5-36. The clamp handle will engage counter-clockwise to loosen the legs in the tube.

4. When the clamp legs are loose, remove the mandrel from the tube.



Figure 5-37. Pull the mandrel out of the tube to remove the machine.

5. If you are finished with the MB Plus, remove the tooling and put the machine back in its storage case.



Chapter 6

Routine Maintenance

MACHINE LUBRICATION

1. There are 2 grease fittings on the MB Plus machine body. Grease the fittings approximately every 1000 hours of machine usage.

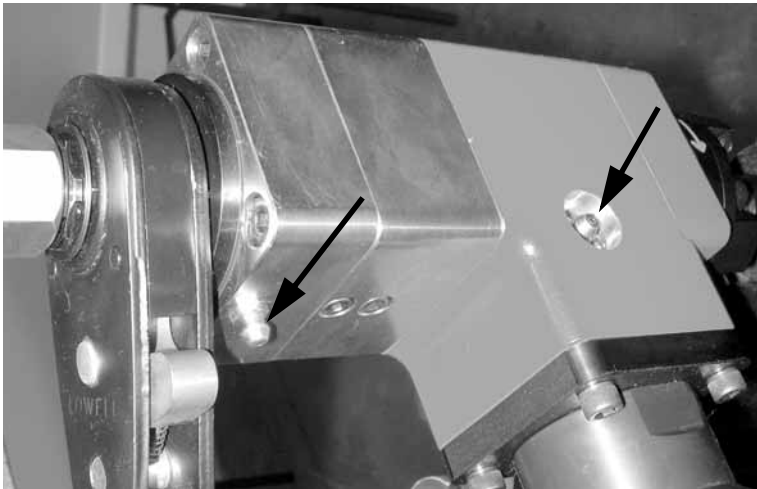

Figure 6-1. Add grease to the two grease fittings about every 1000 hours of use.

AIR MOTOR LUBRICATION

1. Each time you use the MB Plus, check the oil level in the lubricator. Add oil when necessary.

In This Chapter

MACHINE LUBRICATION

AIR MOTOR LUBRICATION

REPLACE AIR LINE FILTER

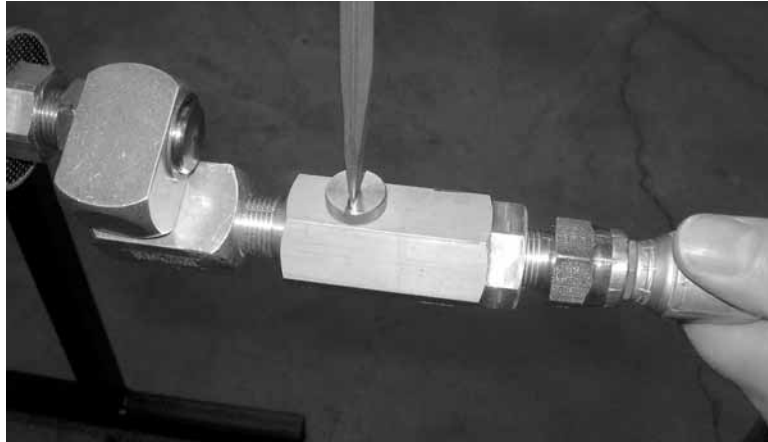

Figure 6-2. Remove the screw in the air motor lubricator to check and add oil.

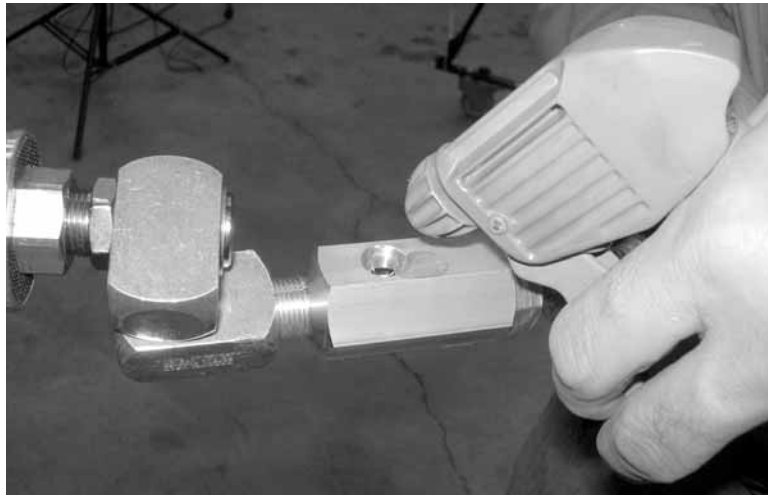

Figure 6-3. Fill the lubricator with air motor oil.

2. Apply light oil to the following components:

- drawbar nut
- drawbar threads
- mandrel threads
- wedge ramps on the mandrel.
- differential screws on the rotating head.

REPLACE AIR LINE FILTER

The air line filter cartridge has a replaceable filter element. If you notice a decrease in speed or power of the MB Plus,

the filter may be clogged. This section describes how to clean or replace the filter element. You should also check the filter once a month—more often for heavy use or if your air supply is not clean.

When servicing the air line components (filter and lubricator), you will need wrench sizes indicated in Figure 6-4.

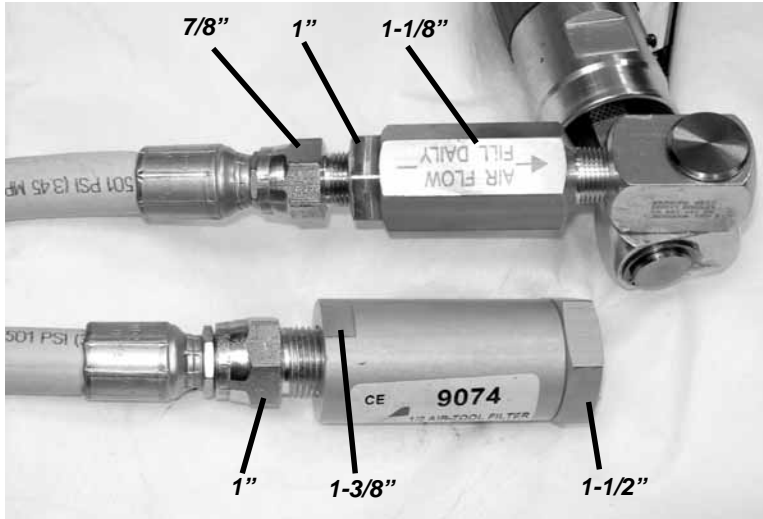

Figure 6-4. The air line connections require the wrench sizes indicated on the photo.

Use the following procedure to inspect the air line filter.

1. Remove any adapter fitting from the filter end of the air hose.



Figure 6-5. Remove any air line adapter from the filter.



NOTE

You may find it easier to remove the air hose if you hold the filter in a bench vise. Secure the vise gently—just enough to hold the filter. Excessive force could break the canister.



2. Remove the filter from the air motor hose.

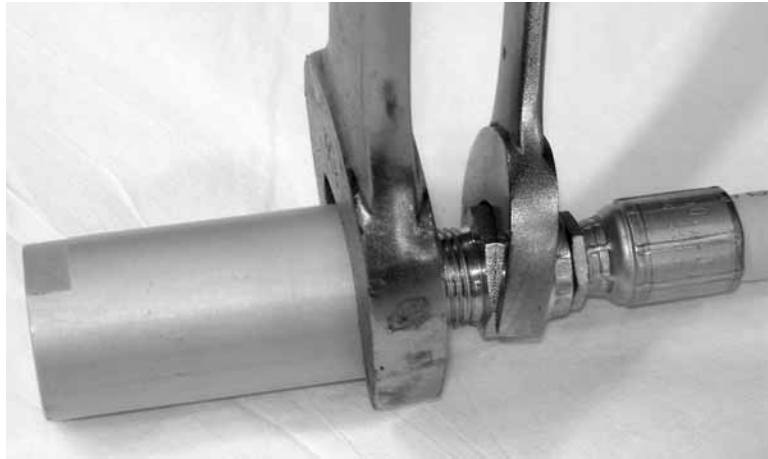

Figure 6-6. Remove the filter from the MB Plus air hose.

3. Remove the end cap from the filter cartridge. The filter element and spring assembly will come out.

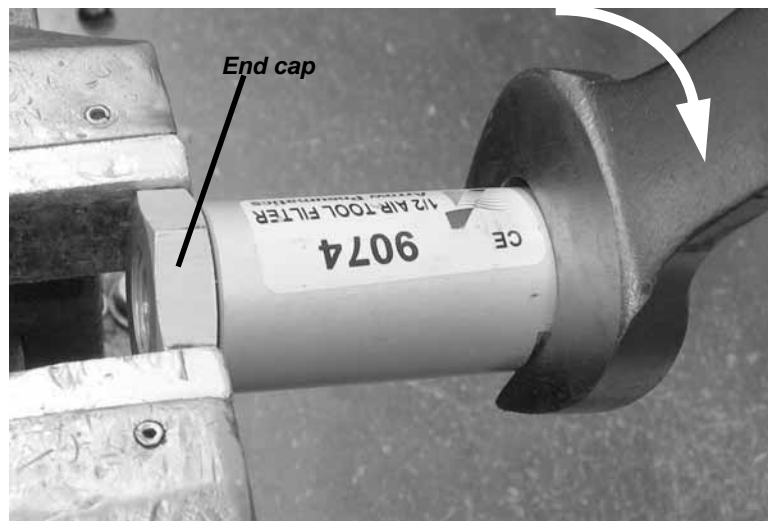

Figure 6-7. Remove the end cap from the cartridge.

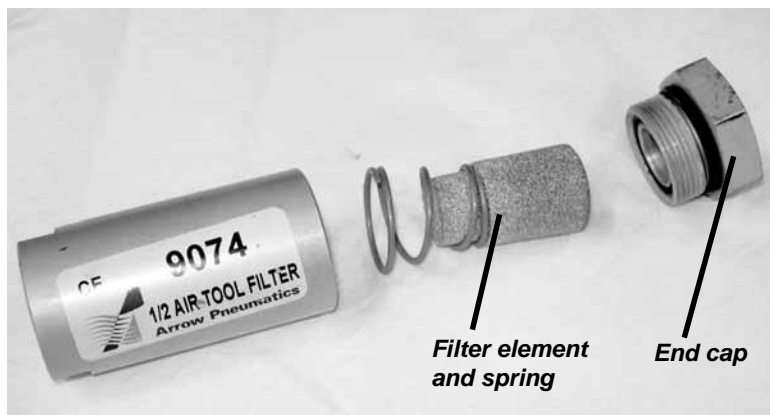

Figure 6-8. You can remove the filter element after taking off the end cap.

4. Inspect the inside of the filter element for debris or residue. You can blow out loose debris with compressed air, or clean the element with soap and water. Clean or replace the element as necessary.



Figure 6-9. Inspect the inside of the filter element. (The photo shows an element in good condition.)

5. Re-assemble the filter element and spring and replace the assembly in the filter cartridge.



Figure 6-10. Replace the element in the filter.

- 6.** Replace the end cap on the cartridge and screw it on fully. Snug the cap with a wrench. Do not overtighten.



Figure 6-11. Replace the end cap on the filter cartridge and snug it with a wrench.

- 7.** Screw the filter cartridge back on the air hose. The air hose is connected to the end of the cartridge labeled "OUT".

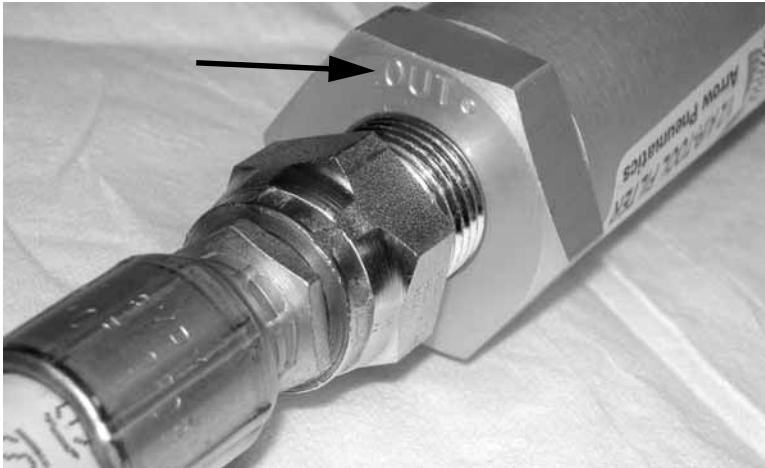

Figure 6-12. Connect the MB Plus air hose to the end of the filter cartridge marked "OUT".



Chapter 7

Service and Repair

REMOVING AND INSTALLING THE DRIVE MOTOR

You do not need to remove the drive motor during normal use of the machine. The following procedure describes how to remove and re-install it for service.

1. Loosen and remove the 4 drive assembly mounting screws using a 3/16" hex wrench.

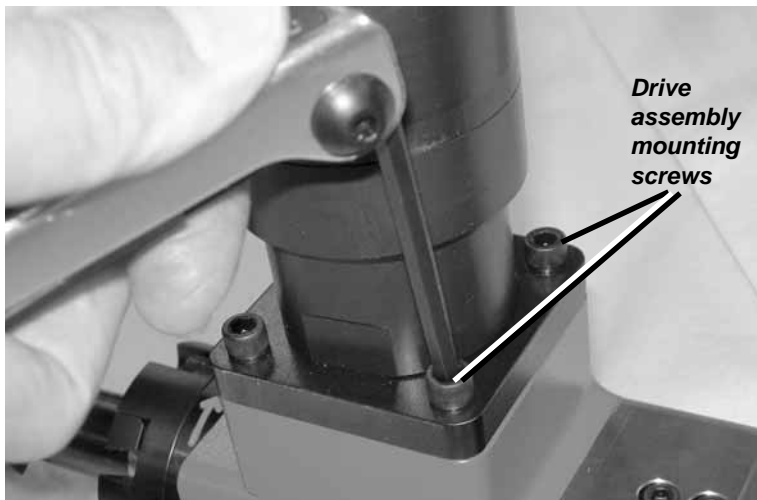

Figure 7-1. Loosen the 4 drive assembly mounting screws.

In This Chapter

REMOVING AND INSTALLING
THE DRIVE MOTOR

AIR MOTOR SERVICE



IMPORTANT

When removing the motor, make sure not to lose the input shaft key. The motor adapter plate holds the pinion gear and input bearing in the housing; do not let these components fall out.

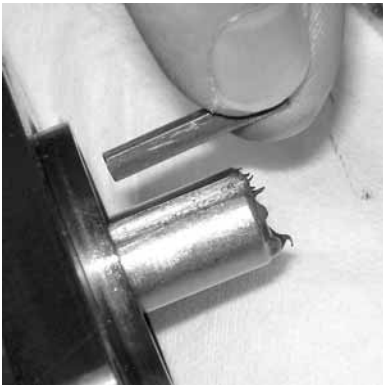

2. Pull on the motor to remove the drive assembly shaft from the bottom of the MB Plus machine body.

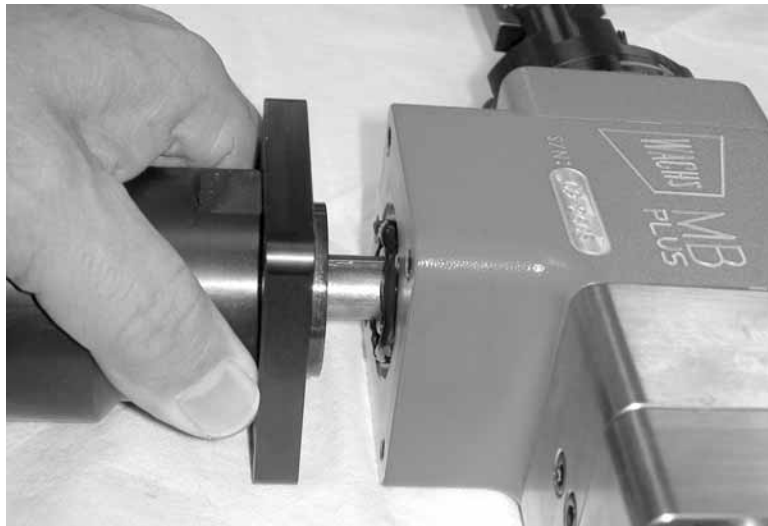

Figure 7-2. Pull the motor shaft out of the machine body.

3. To re-install the drive assembly, align the input shaft key with the slot in the pinion gear. Insert the shaft into the gear.

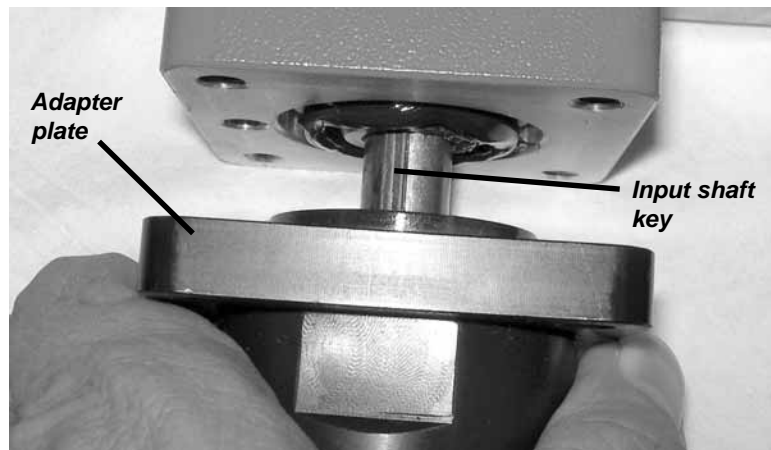

Figure 7-3. Align the key on the input shaft with the slot in the pinion gear.

4. Turn the body of the drive assembly to the desired orientation, and line up the 4 mounting holes in the adapter plate with the holes in the bottom of the machine body.
5. Insert the 4 screws and tighten them securely.



NOTE

You can install the drive assembly with the power trigger in any 90° orientation.

AIR MOTOR SERVICE

0.75 HP Configuration (71-000-04)

An exploded view drawing of the 0.75 HP air motor (71-026-00) is included in Chapter 8. Refer to it for assembly/disassembly and use the parts list on the drawing for ordering spare or replacement parts.

1.1 HP Configuration (71-000-05)

An exploded view drawing of the 1.1 HP air motor is included in Chapter 8. Refer to it for assembly/disassembly and for ordering spare or replacement parts.

Clean and grease all gears at least every 2,000 hours of use. Inspect the items shown in Figure 7-4, and replace any that are worn or damaged. You should replace the vanes each time you overhaul the motor.

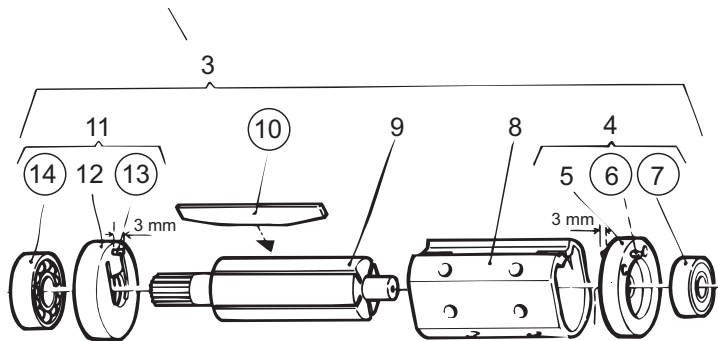

Figure 7-4. Replace the air motor vanes (item 10) every time you overhaul the motor. A service kit containing the circled item numbers (6,7,10,13,14) is available; order part number 4081 0043 90.



Chapter 8

Parts Lists and Drawings

.....

ASSEMBLY DRAWINGS

The drawings on the following pages illustrate the machine assemblies for the pneumatic drive MB Plus configurations. Each drawing includes a parts list. Use these drawings to identify and order replacement parts.

Electric drive configurations of the MB Plus are obsolete. Spare and replacement parts may be available; refer to drawings for 71-000-06 and 71-000-07 at the end of this chapter.

MB Plus, 0.75 HP Air Drive Configuration

ITEM	PART NUMBER	QTY	DESCRIPTION
1	16-009-00	2	KEY, MANDREL
2	16-082-00	1	CASE [NOT SHOWN]
3	70-MAN-01	1	SB/AMB/LB SETUP SHEET [NOT SHOWN]
4	71-008-01	1	HOUSING, KEY
5	71-029-00	1	BEARING
6	71-029-00	1	BEARING
7	71-029-00	1	BEARING
8	71-051-00	1	SHAFT INPIIT ADAPTER
9	71-059-00	1	FOAM INSERT [NOT SHOWN]
10	71-062-00	1	LABEL, MOVING PARTS
11	71-402-01	1	'MB' DRAWBAR BATCHET ASSEMBLY
12	71-406-00	1	AIR MOTOR ASSY.
13	71-408-00	1	BEARING ASSEMBLY
14	71-409-00	1	BEARING ASSEMBLY
15	71-409-00	1	WEDGELOCK HEAD ASSEMBLY
16	71-410-00	1	'MB' MANDREL ASSEMBLY
17	71-MAN-03	1	'MB PLUS' MANUAL [NOT SHOWN]
18	80-402-00	1	ATM HOSE
19	90-000-07	4	SHCS, 10-24 X 3/4
20	90-050-05	3	SHCS, 1/4-20 X 3/8
21	90-050-05	3	SHCS, 1/4-20 X 3/8
22	90-050-25	4	SHCS, 1/4-20 X 2.5
23	90-401-05	1	LABEL, 3/4" DIA EYE PROTECTION
24	90-800-06	1	WRENCH, 5/64" - 1/4" HEX SET [NOT SHOWN]
25	90-800-22	1	WRENCH, 1/8" HEX SHORT ARM [NOT SHOWN]

NOTE:
 1. MAX OPERATING WEIGHT USING 71-400-05 LEG SET: 18.6 lbs / 8.4 kg
 2. TOTAL SHIPPING WEIGHT: 35.6 lbs / 16.1 kg
 3. EXTERIOR CASE DIMENSIONS: 24.25" X 19.45" X 8.68"
 (61.8 X 49.3 X 22 cm)

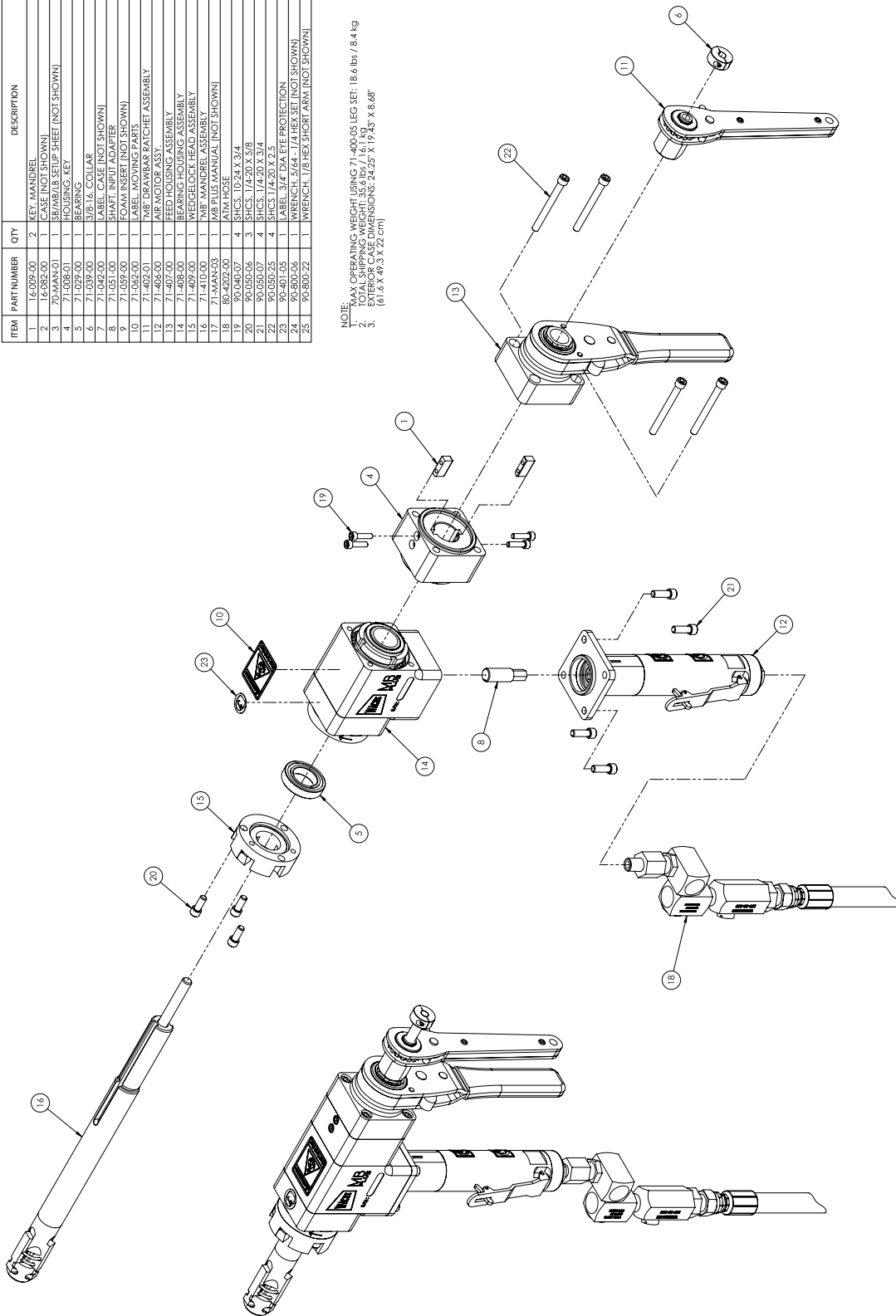

MB Plus, 1.1 HP Air Drive Configuration

ITEM	PART NUMBER	QTY	DESCRIPTION
1	14-008-00	2	KEY, MANUREL
2	14-092-00	1	CASE (NOT SHOWN)
3	70-MAN-01	1	SRV/MAB SETUP SHEET (NOT SHOWN)
4	71-005-00	1	HEAD, TOOL - LARGE (NOT SHOWN)
5	71-008-01	1	HOUSING, KEY
6	71-029-00	1	BEARING
7	71-039-00	1	3/8-16 COLLAR
8	71-042-00	1	LABEL CASE (NOT SHOWN)
9	71-043-00	1	KEY (NOT SHOWN)
10	71-042-00	1	LABEL HOUSING PARTS
11	71-402-01	1	M8 DRAWBAR RATCHET ASSEMBLY
12	71-404-00	1	AIR MOTOR ASSY.
13	71-405-00	1	AIR HOSE
14	71-407-00	1	FEED HOUSING ASSEMBLY
15	71-408-00	1	BEARING HOUSING ASSEMBLY
16	71-409-00	1	WEDGELock HEAD ASSEMBLY
17	90-000-00	1	DRIVE SHAFT ASSEMBLY
18	71-144-03	1	M8 BUSH MANUREL (NOT SHOWN)
19	90-000-07	4	SHCS, 10-24 X 3/4
20	90-050-06	3	SHCS, 1/4-20 X 5/8
21	90-050-07	4	SHCS, 1/4-20 X 3/4
22	90-050-25	4	SHCS, 1/4-20 X 2.5
23	90-401-05	1	LABEL, 3/4" DIA EYE PROTECTION
24	90-800-06	1	WRENCH, 5/64"-1/4" HEX SET (NOT SHOWN)
25	90-800-22	1	WRENCH, 1/8" HEX SHORT LARKI (NOT SHOWN)

NOTE:
 1. MAX OPERATING WEIGHT USING 71-400-08 LEG SET: 23.2 lbs / 10.5 kg
 2. TOTAL SHIPPING WEIGHT: 42.2 lbs / 19.1 kg
 3. DIMENSIONS: 11.5" X 11.5" X 11.5" (29.2 cm X 29.2 cm X 29.2 cm)
 4. DIMENSIONS: 24.25" X 19.45" X 8.68"

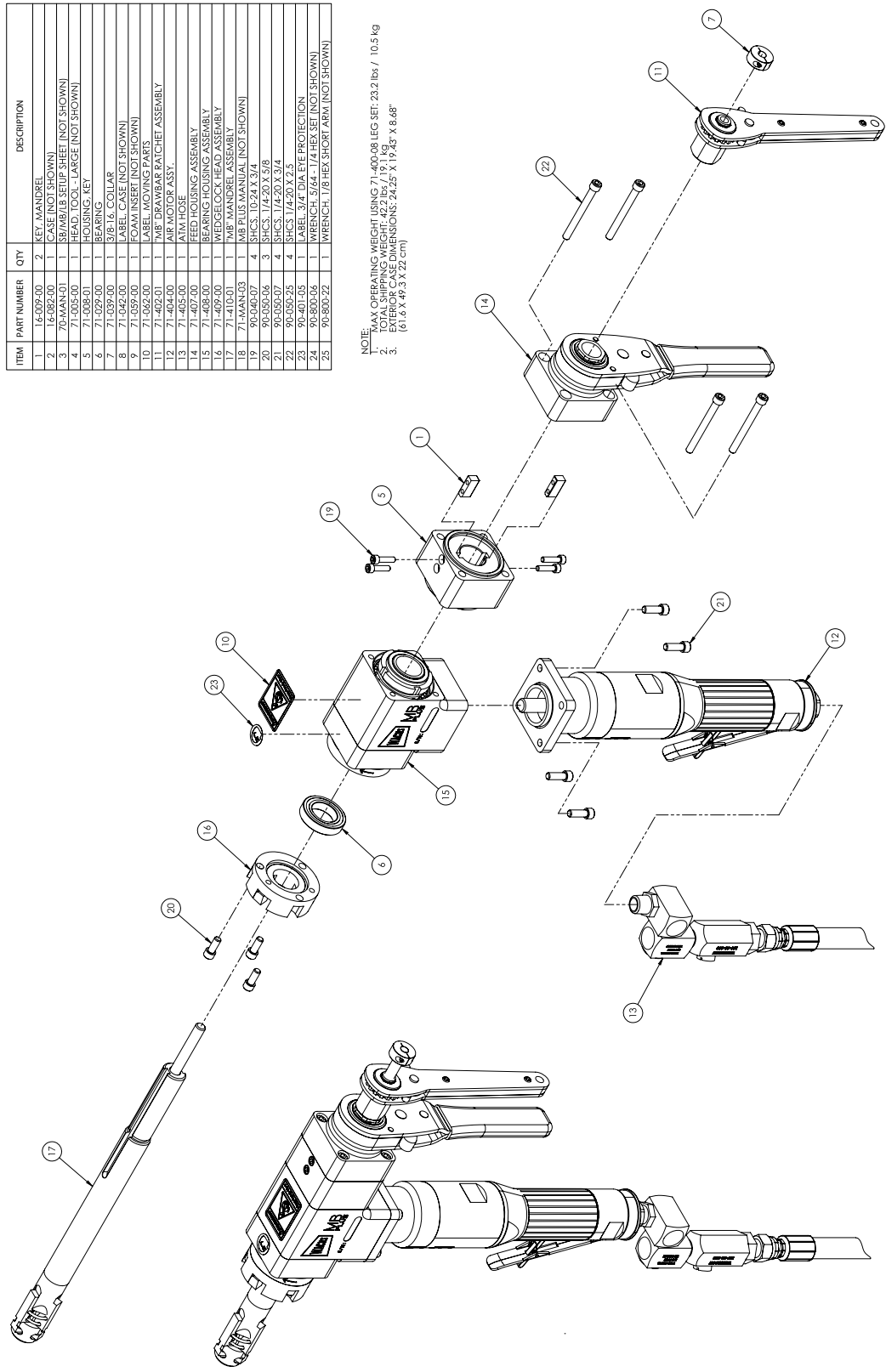

Drawbar Ratchet Assembly, 71-402-01

ITEM	PART NUMBER	QTY	DESCRIPTION
1	71-018-02	1	NUT, DRAWBAR
2	71-019-02	1	NUT, COLLAR
3	71-036-01	1	RING, SPIRAL RETAINING
4	71-038-01	1	RATCHET, DRAWBAR
5	71-056-00	1	RING, SNAP
6	71-057-00	1	O-RING (-115) BUNA-N

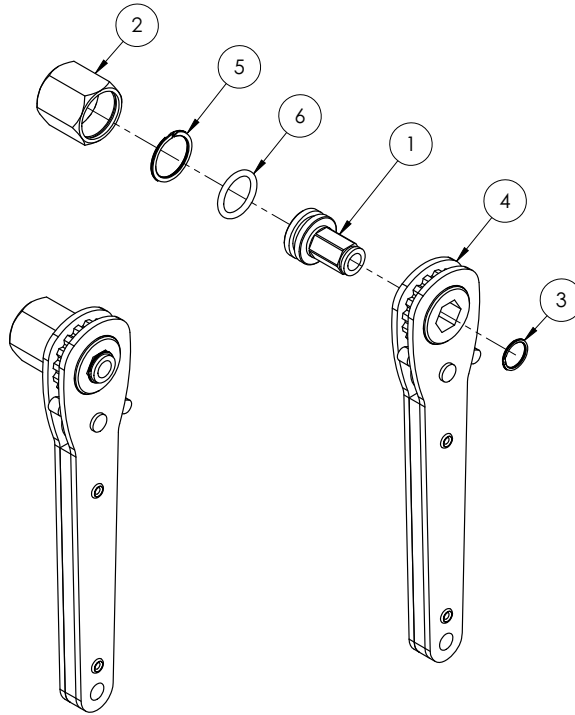

Feed Housing Assembly, 71-407-00

ITEM	PART NUMBER	QTY	DESCRIPTION
1	71-010-01	1	NUT, FEED
2	71-011-01	1	HOUSING, FEED NUT
3	71-012-01	1	WASHER
4	71-032-01	1	O-RING (-224) BUNA-N
5	71-034-01	1	RING, SNAP
6	71-035-00	1	RING, SPIRAL RETAINING
7	71-037-00	1	ARM, RATCHET 1"
8	90-500-05	1	1/4-28 GREASE ZERK

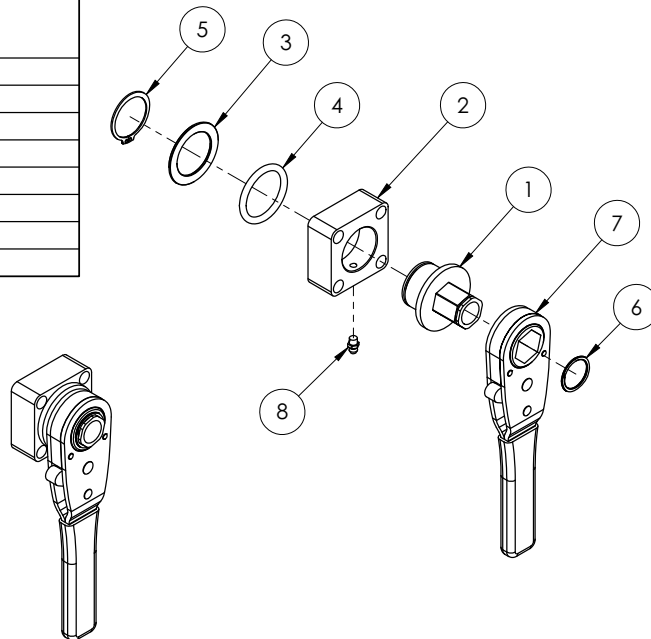

Bearing Housing Assembly, 71-408-00

ITEM	PART NUMBER	QTY	DESCRIPTION
1	16-007-00	1	GEAR, PINION
2	26-096-00	1	BEARING
3	26-097-00	1	RETAINING RING, EXTERNAL
4	71-001-01	1	HOUSING, MB BEARING
5	71-003-00	1	SHAFT, MAIN
6	71-006-01	1	GEAR, RING
7	71-021-00	1	BEARING, W/CONE-SEAL
8	71-027-00	2	BEARING, CUP
9	71-028-00	1	CONE
10	71-030-00	1	LOCKNUT
11	71-050-00	1	CAP, FRONT BEARING
12	71-061-00	1	KEY, 1/8 SQ X 7/8
13	90-027-06	1	KEY, 1/8 SQ X 5/8
14	90-050-11	4	SHCS, 1/4-20 X 1-1/8
15	90-500-05	1	1/4-28 GREASE ZERK

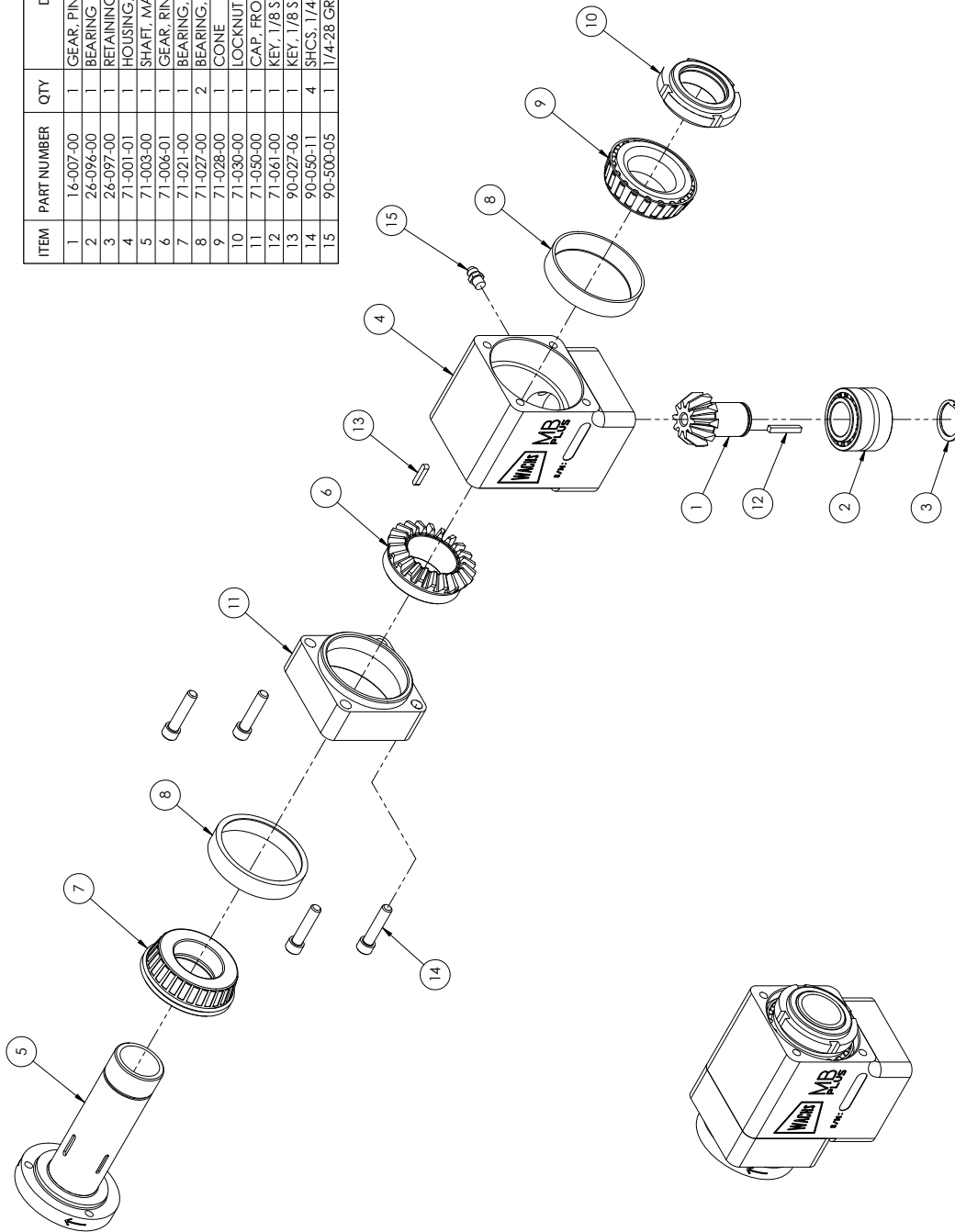

Wedglock Head Assembly, 71-409-00

ITEM	PART NUMBER	QTY	DESCRIPTION
1	70-022-00	2	WEDGE
2	70-023-00	2	SCREW, DIFERENTIAL
3	71-004-00	1	HEAD, TOOL-SMALL
4	90-054-05	2	SSS, 1/4-20 X 1/2

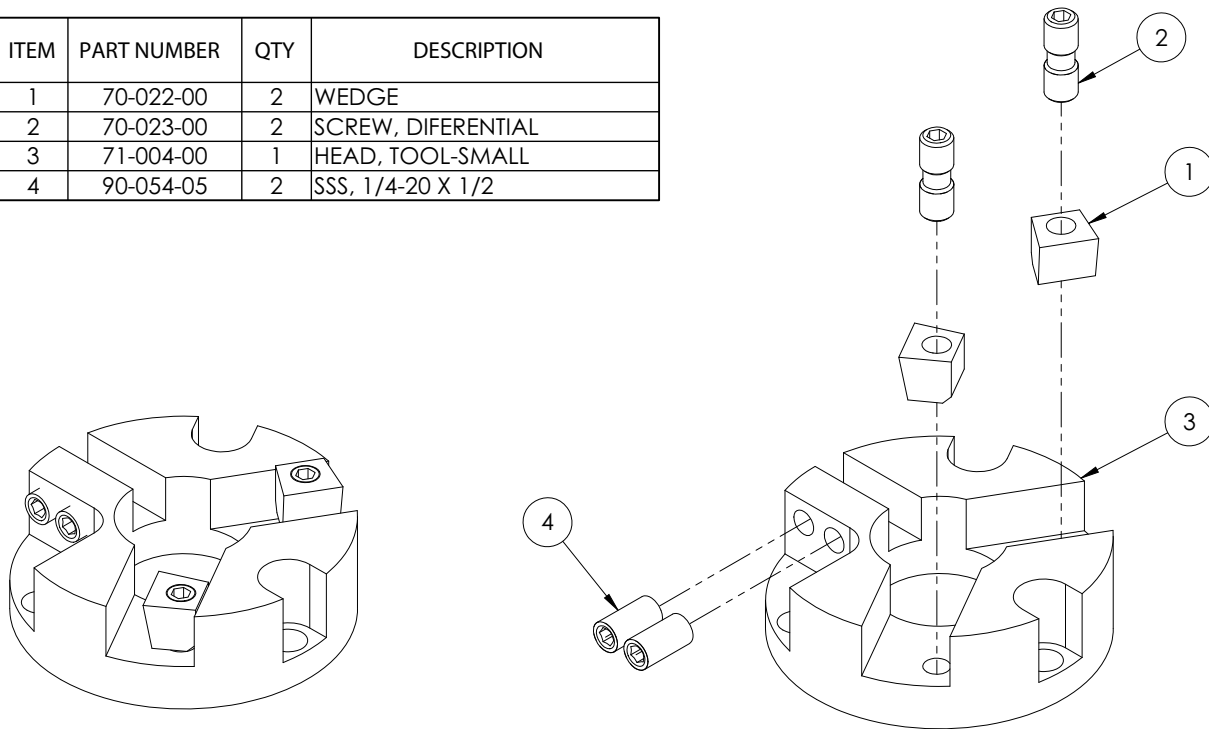

Mandrel Assembly with Standard Leg Set, 71-410-00

ITEM	PART NUMBER	QTY	DESCRIPTION
1	71-014-01	1	MANDREL
2	71-015-02	1	DRAWBAR ASSEMBLY
3	WHERE USED	1	LEG SET ASSEMBLY

-WHERE USED-		
ITEM	PART NO.	DESCRIPTION
3	71-400-01	LEG SET ASSEMBLY 1.00 - 1.32 [25.4 - 33.5mm]
	71-400-02	LEG SET ASSEMBLY 1.25 - 1.56 [31.8 - 39.6mm]
	71-400-03	LEG SET ASSEMBLY 1.49 - 1.80 [37.8 - 45.7mm]
	71-400-04	LEG SET ASSEMBLY 1.73 - 2.05 [43.9 - 52.1mm]
	71-400-05	LEG SET ASSEMBLY 1.98 - 2.30 [50.3 - 58.4mm]

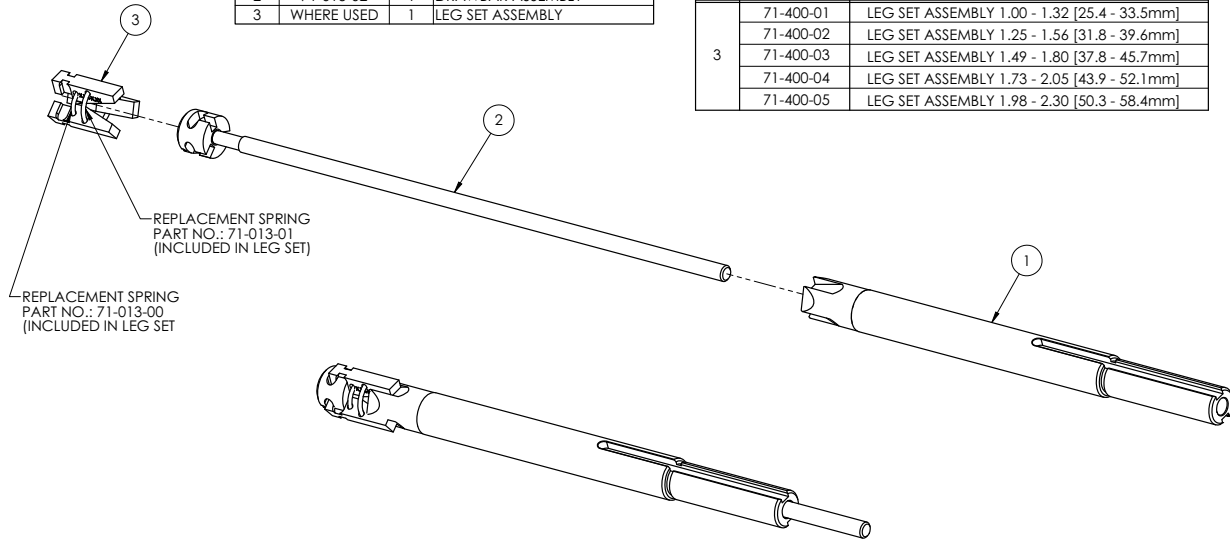

Mandrel Assembly with Extended Leg Set, 71-410-01

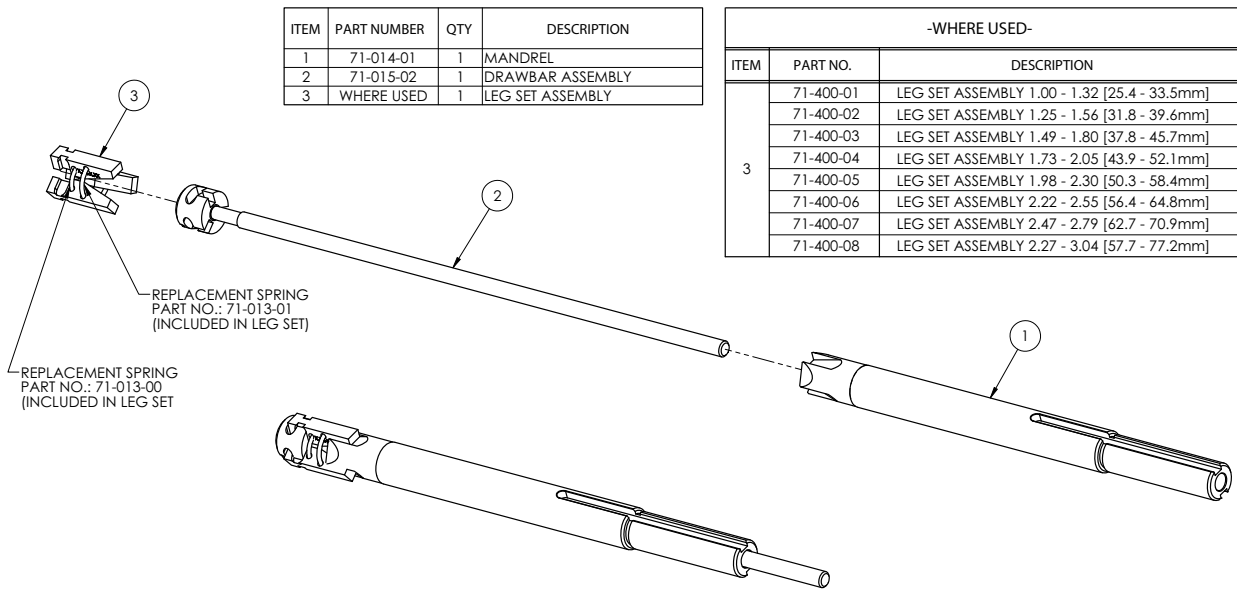

Extended Range (3.0") Kit, 71-401-00

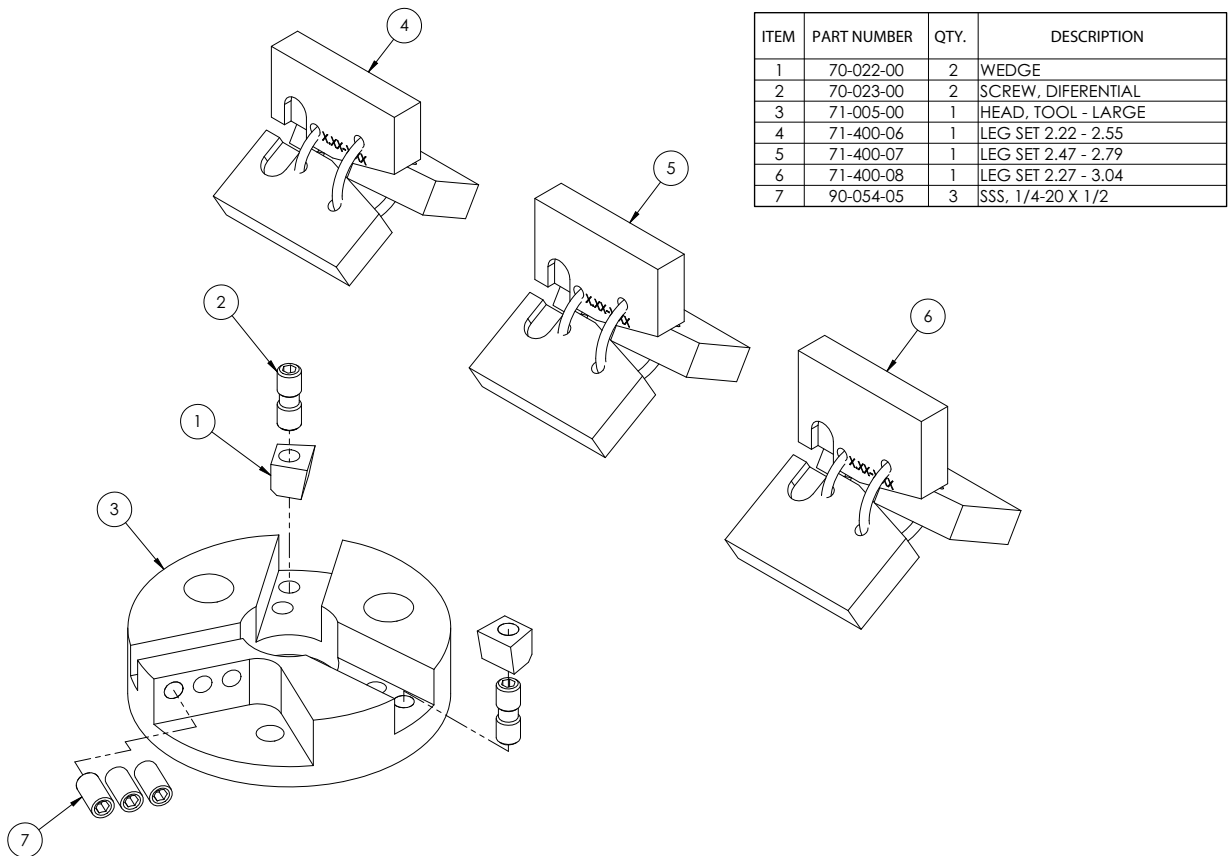

0.75 HP Air Motor Assembly, 71-406-00

ITEM	PART NUMBER	QTY.	DESCRIPTION
1	71-024-01	1	ADAPTER, SMALL AIR MOTOR
2	71-026-00	1	MB AIR MOTOR
3	90-401-00	1	LABEL, EAR PROTECTION
4	90-401-02	1	LABEL, PRESSURE-AIR

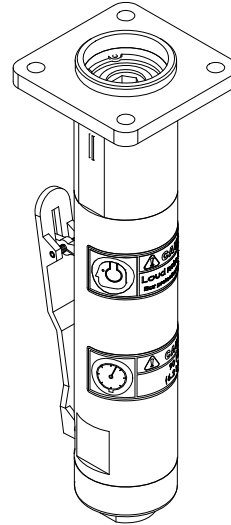
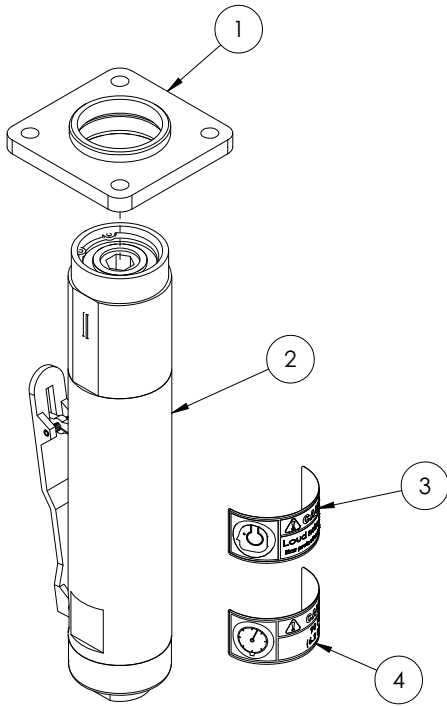

0.75 HP Air Motor, 71-026-00

ITEM	PART NUMBER	QTY.	DESCRIPTION
1	CLE-201666	1	SUBASM: LOCK-OFF LEVER
1.1	CLE-204325	1	LOCK-OFF LEVER
1.2	CLE-202105	1	TOGGLE
1.3	CLE-845409	1	PIN: SPRING
1.4	CLE-869855	1	SPRING: TOGGLE
2	CLE-202075	1	PIN: DOWEL
3	CLE-301073	1	SUBASM: GEAR TRAIN (BD-2)
3.1	CLE-202263	1	GEAR: CASE
3.2	CLE-844384	1	RING: RETAINING
3.3	CLE-847147	1	BALL BEARING
3.4	CLE-203785	1	SPIDER: 16.0 CLOSED
3.5	CLE-203781	3	GEAR: IDLER
3.5.1	CLE-866265	1	2ND RED. IDLER GEAR
3.5.2	CLE-203784	1	NEEDLE BEARING
3.6	CLE-203783	3	PIN: IDLER GEAR
3.7	CLE-203786	1	SPIDER: OPEN
3.7.1	CLE-203793	3	PIN: IDLER GEAR
3.8	CLE-204280	1	SPIDER: OPEN
3.8.1	CLE-203793	3	PIN: IDLER GEAR
3.9	CLE-865576	1	RACE: THRUST
3.10	CLE-203782	6	1ST RED. IDLER GEAR
3.10.1	CLE-866284	1	1ST RED. IDLER GEAR
3.10.2	CLE-203749	1	NEEDLE BEARING
3.11	CLE-867902	1	PINION
3.12	CLE-869584	1	SPACER: PINION
4	CLE-833188	1	SPRING: PLUNGER
5	CLE-844309	1	O-RING
6	CLE-847808	1	PIN: GROOVE
7	CLE-863454	1	O-RING
8	CLE-863879	1	BEARING: BALL
9	CLE-867882	1	BUSHING: INLET
9.1	CLE-833300	1	SCREEN
10	CLE-849445	1	BEARING: REAR ROTOR
11	CLE-869451	1	CYLINDER
11.1	CLE-812165	2	PIN: SPRING
12	CLE-869583	1	SPACER: GEAR CASE
13	CLE-869720	1	PLATE: FRONT BEARING
14	CLE-869788	4	ROTOR BLADE
15	CLE-869842	1	PLATE: REAR BEARING
15.1	CLE-812167	1	PIN: SPRING
16	CLE-869843	1	BACKHEAD
17	CLE-869844	1	EXHAUST DEFLECTOR
18	CLE-869845	1	SEAT: VALVE
19	CLE-869847	1	VALVE: THROTTLE
19.1	CLE-844083	1	PIN: DOWEL
20	CLE-869848	1	ROTOR
21	CLE-869850	2	MUFFLER

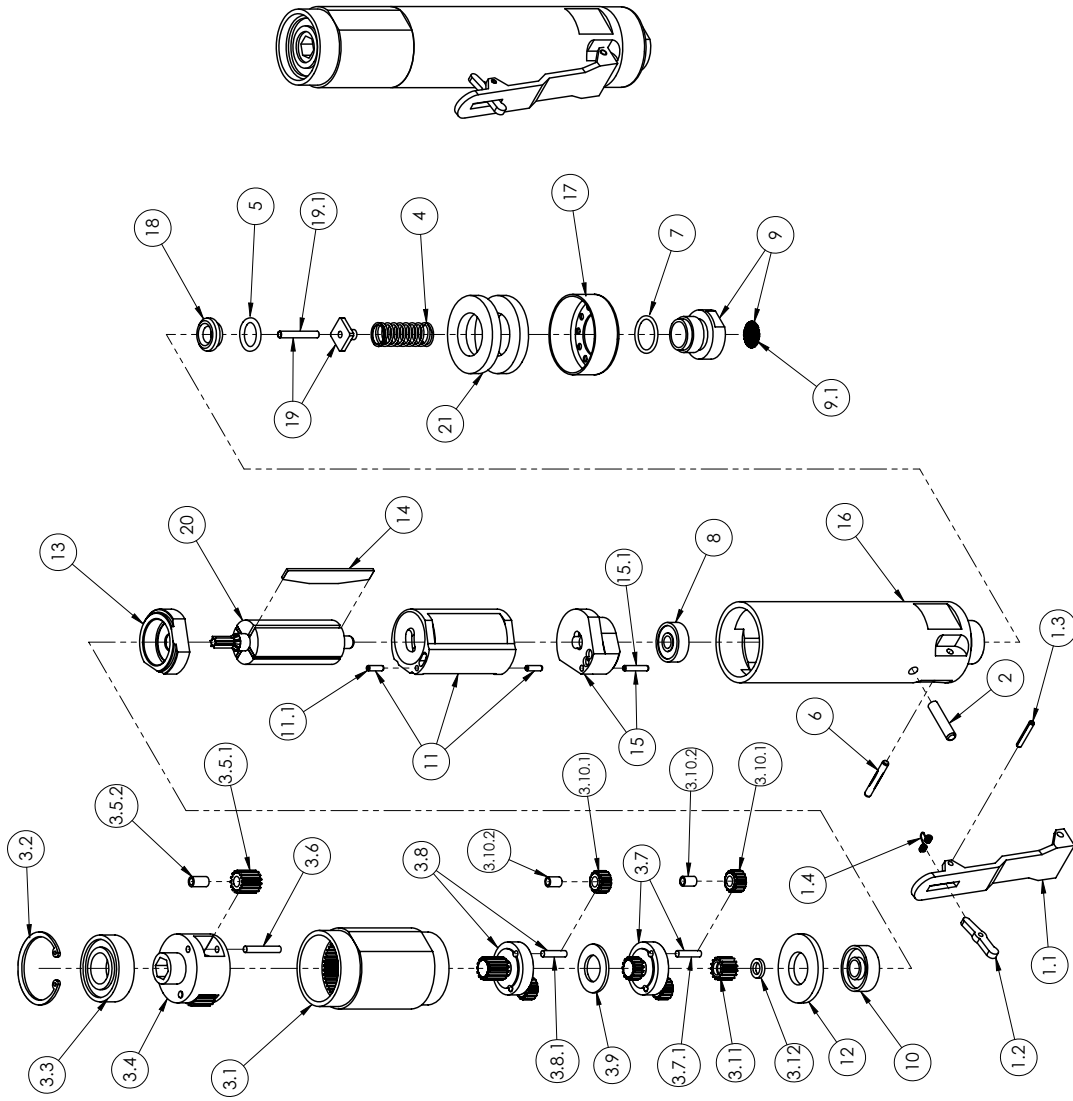

1.1 HP Air Motor Assembly, 71-404-00

ITEM	PART NUMBER	QTY	DESCRIPTION
1	71-024-03	1	ADAPTER, LARGE AIR MOTOR
2	71-060-00	1	MOTOR, AIR
3	90-401-00	1	LABEL, EAR PROTECTION
4	90-401-02	1	LABEL, PRESSURE-AIR

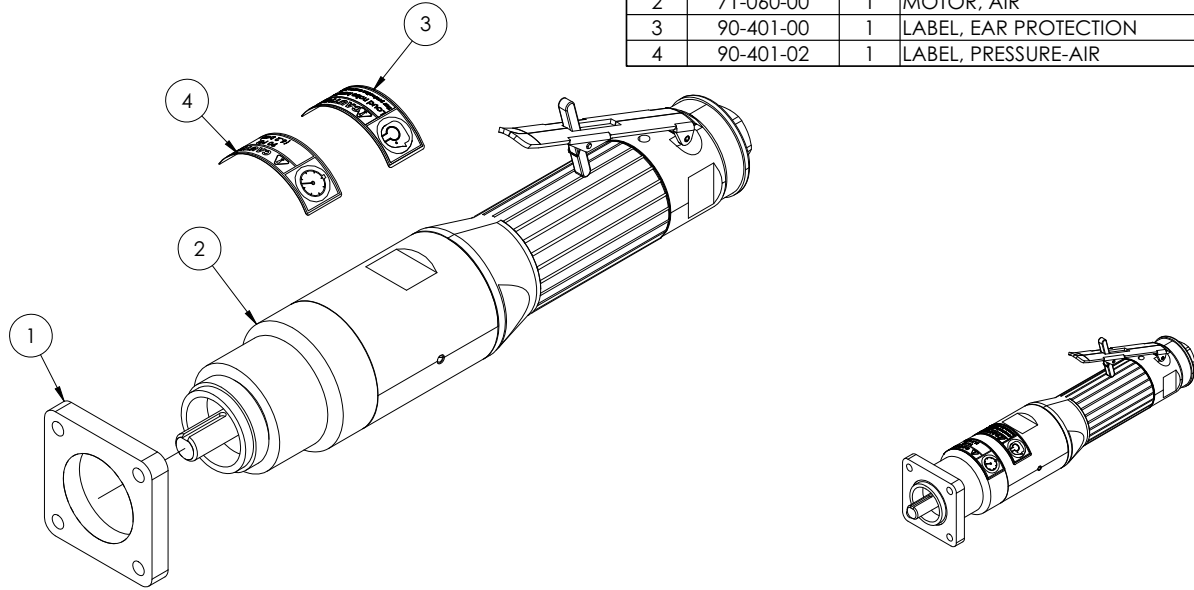

1.1 HP Air Motor, 71-060-00

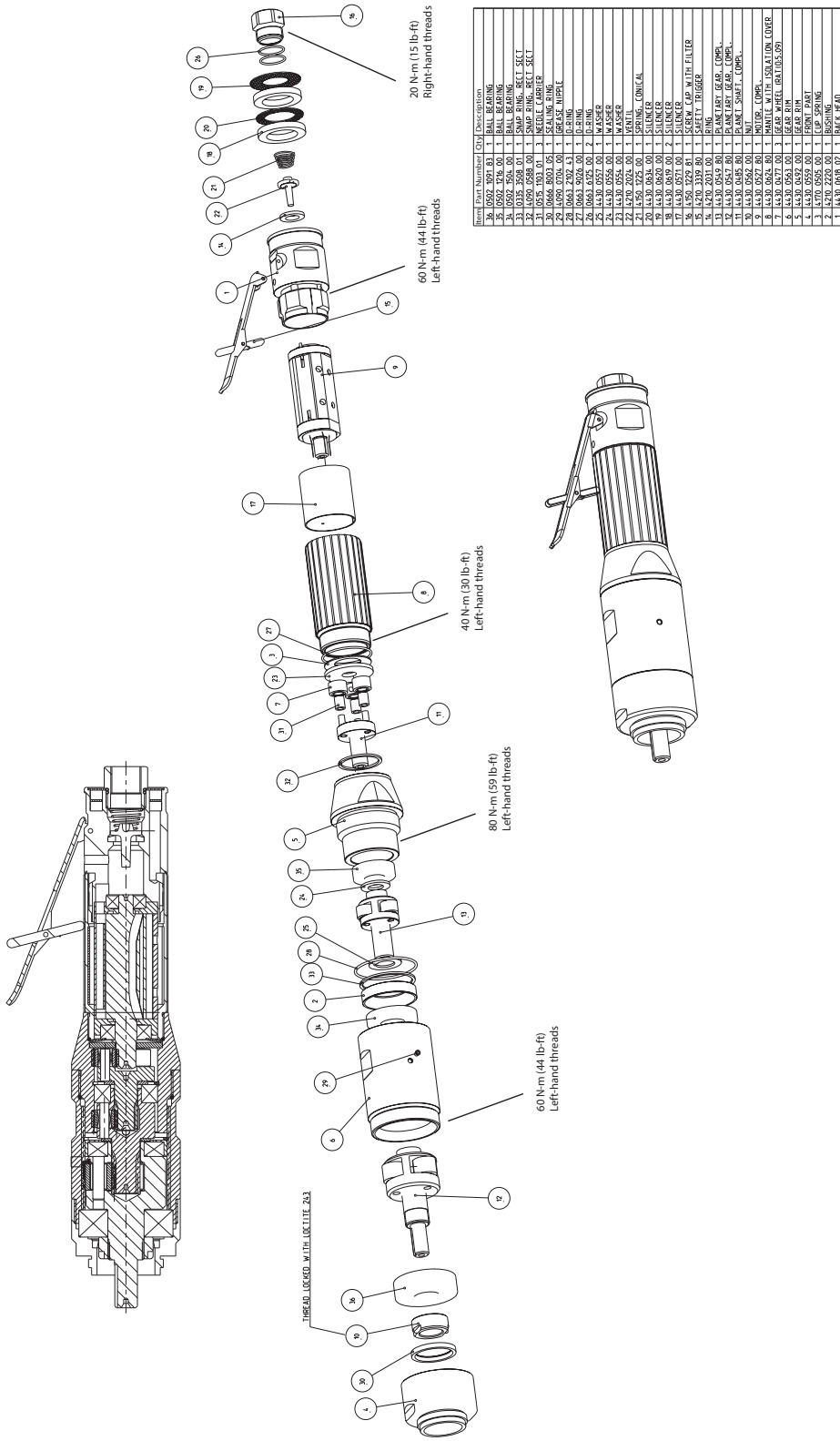

ATM Hose (for 0.75 HP Air Drive), 80-4202-00

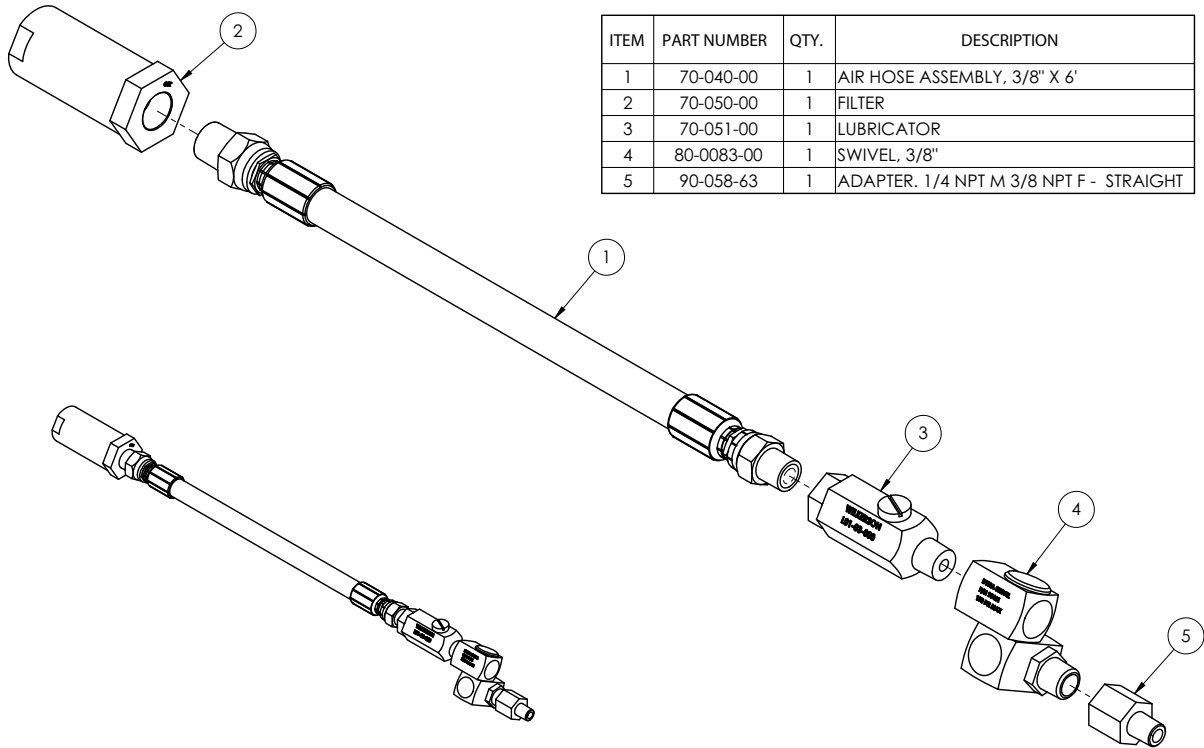

ITEM	PART NUMBER	QTY.	DESCRIPTION
1	70-040-00	1	AIR HOSE ASSEMBLY, 3/8" X 6'
2	70-050-00	1	FILTER
3	70-051-00	1	LUBRICATOR
4	80-0083-00	1	SWIVEL, 3/8"
5	90-058-63	1	ADAPTER, 1/4 NPT M 3/8 NPT F - STRAIGHT

ATM Hose (for 1.1 HP Air Drive), 71-405-00

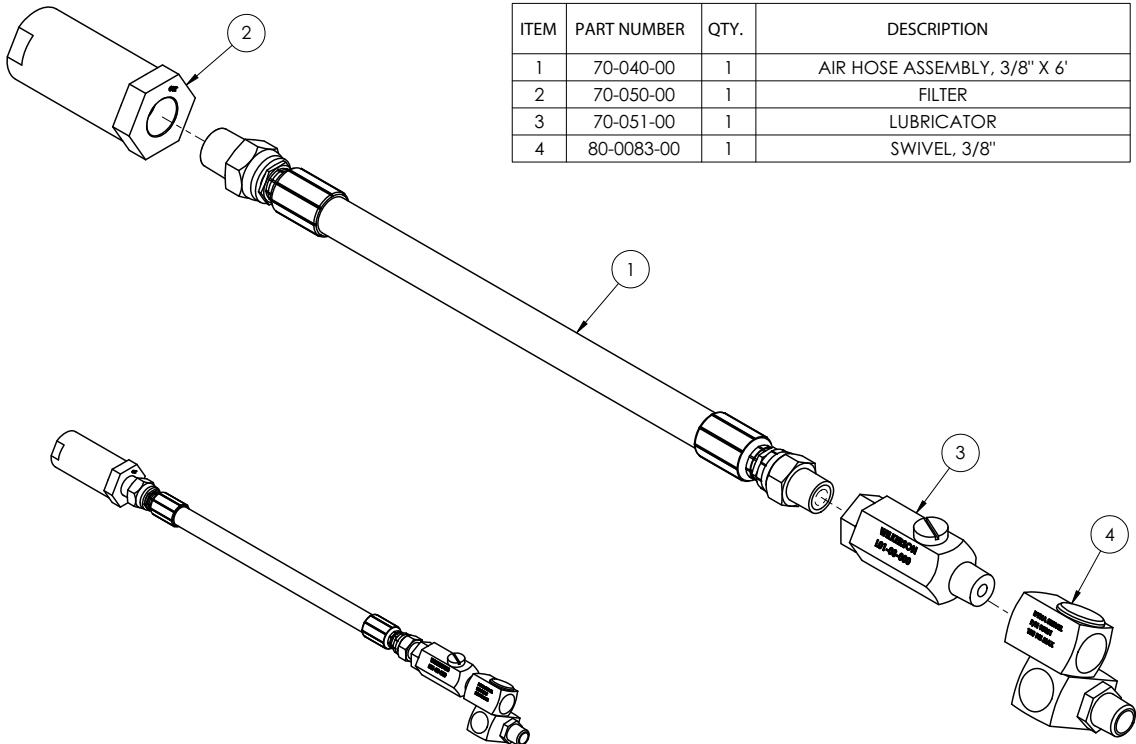

ITEM	PART NUMBER	QTY.	DESCRIPTION
1	70-040-00	1	AIR HOSE ASSEMBLY, 3/8" X 6'
2	70-050-00	1	FILTER
3	70-051-00	1	LUBRICATOR
4	80-0083-00	1	SWIVEL, 3/8"

110 V Electric Drive MB Plus (Obsolete), 71-000-06

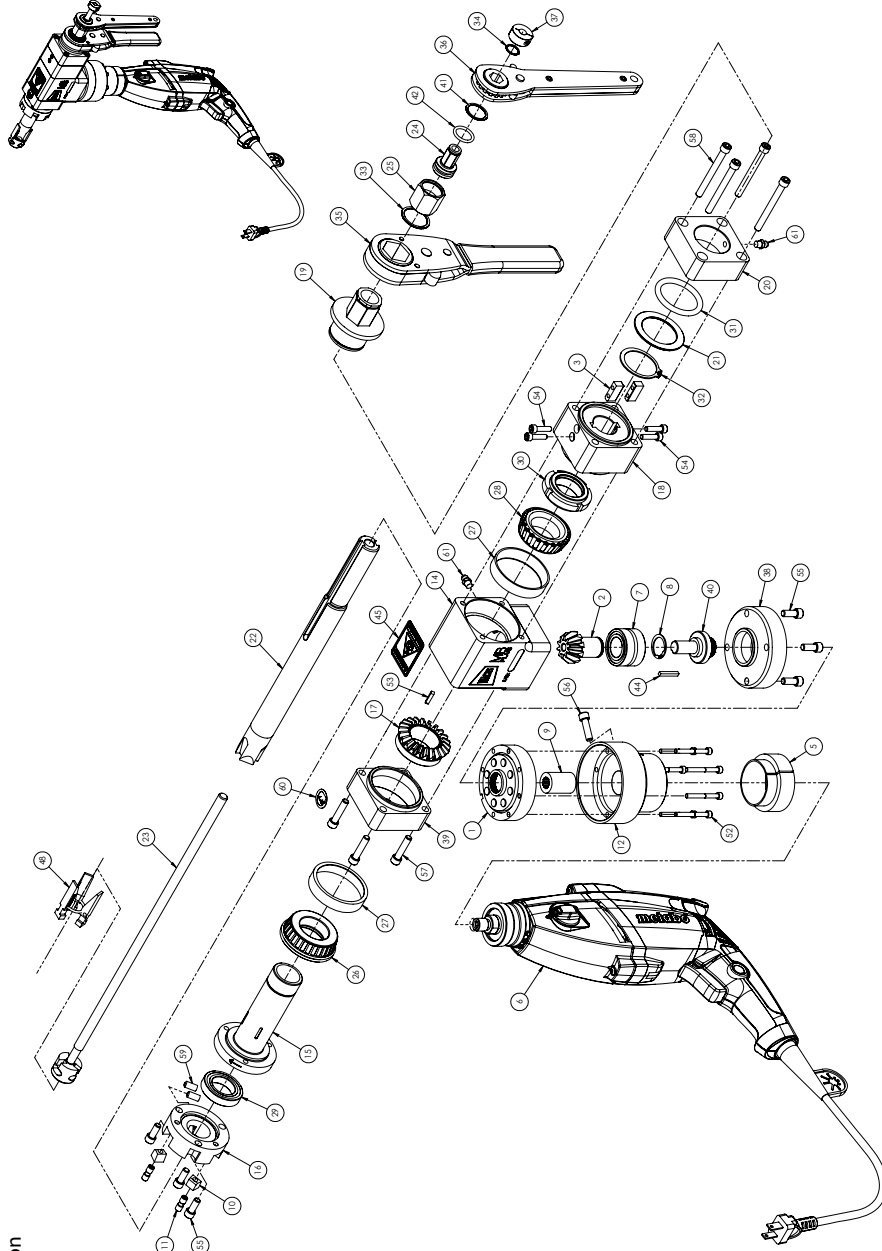

MB Plus 110 V Electric Drive Configuration
71-000-06
OBSOLETE

ITEM	PART NUMBER	QTY.	DESCRIPTION
1	14-007-00	1	CONNECTOR, ELECTRICAL OUTPUT
2	14-009-00	2	LEAK PINNAC
3	14-009-00	2	LEAK MANIFOLD
4	14-010-00	1	LEAK MANIFOLD (NOT SHOWN)
5	19-014-00	1	ADAPTER MOTOR
6	20-031-01	1	MOTOR, RELAYED 110V
7	24-009-00	1	BEARING, BALL
8	24-010-00	1	BEARING, BALL
9	24-124-02	2	COURTAIN INLET
10	26-022-00	2	WHEEL
11	26-023-00	2	WHEEL
12	26-049-00	1	HOUSING, GEARSET
13	70-040-01	1	BEARING, BALL (NOT SHOWN)
14	70-040-01	1	BEARING, BALL (NOT SHOWN)
15	71-003-00	1	SHAFT MAIN
16	71-004-00	1	HEAD, TOOLSMALL
17	71-004-00	1	HEAD, TOOLSMALL
18	71-008-01	1	HOUSING KEY
19	71-010-01	1	NUF, FEED
20	71-010-01	1	NUF, FEED
21	71-012-01	1	WASHER, FEEDNUT
22	71-014-01	1	WASHER
23	71-014-01	1	WASHER
24	71-018-02	1	NUF, DRUMWALK
25	71-019-02	1	NUF, COLAR
26	71-020-00	1	BEARING, BALL
27	71-027-00	2	BEARING, CUP
28	71-028-00	1	WHEEL
29	71-028-00	1	WHEEL
30	71-030-00	1	LOCKNUT
31	71-032-01	1	5-RING, LEVER BINMAN
32	71-032-01	1	5-RING, LEVER BINMAN
33	71-035-00	1	5-RING, LEVER BINMAN
34	71-034-01	1	5-RING, LEVER BINMAN
35	71-034-01	1	5-RING, LEVER BINMAN
36	71-034-01	1	5-RING, LEVER BINMAN
37	71-039-00	1	5-RING, LEVER BINMAN
38	71-040-01	1	5-RING, LEVER BINMAN
39	71-040-01	1	5-RING, LEVER BINMAN
40	71-040-01	1	5-RING, LEVER BINMAN
41	71-040-01	1	5-RING, LEVER BINMAN
42	71-040-01	1	5-RING, LEVER BINMAN
43	71-040-01	1	5-RING, LEVER BINMAN
44	71-040-01	1	5-RING, LEVER BINMAN
45	71-040-01	1	5-RING, LEVER BINMAN
46	71-040-01	1	5-RING, LEVER BINMAN
47	71-040-01	1	5-RING, LEVER BINMAN
48	71-040-01	1	5-RING, LEVER BINMAN
49	71-040-01	1	5-RING, LEVER BINMAN
50	71-040-01	1	5-RING, LEVER BINMAN
51	71-040-01	1	5-RING, LEVER BINMAN
52	71-040-01	1	5-RING, LEVER BINMAN
53	71-040-01	1	5-RING, LEVER BINMAN
54	71-040-01	1	5-RING, LEVER BINMAN
55	71-040-01	1	5-RING, LEVER BINMAN
56	71-040-01	1	5-RING, LEVER BINMAN
57	71-040-01	1	5-RING, LEVER BINMAN
58	71-040-01	1	5-RING, LEVER BINMAN
59	71-040-01	1	5-RING, LEVER BINMAN
60	71-040-01	1	5-RING, LEVER BINMAN
61	71-040-01	1	5-RING, LEVER BINMAN
62	71-040-01	1	5-RING, LEVER BINMAN
63	71-040-01	1	5-RING, LEVER BINMAN

MAX. OPERATING WEIGHT: 11.05 LBS (5.01 KG)
TOTAL SHIPPING WEIGHT: 18.99 LBS (8.61 KG)
PACKING DIMENSIONS: 24.5" X 19.2" X 8.64"
PART NO. 71-000-06

220 V Electric Drive MB Plus (Obsolete), 71-000-07

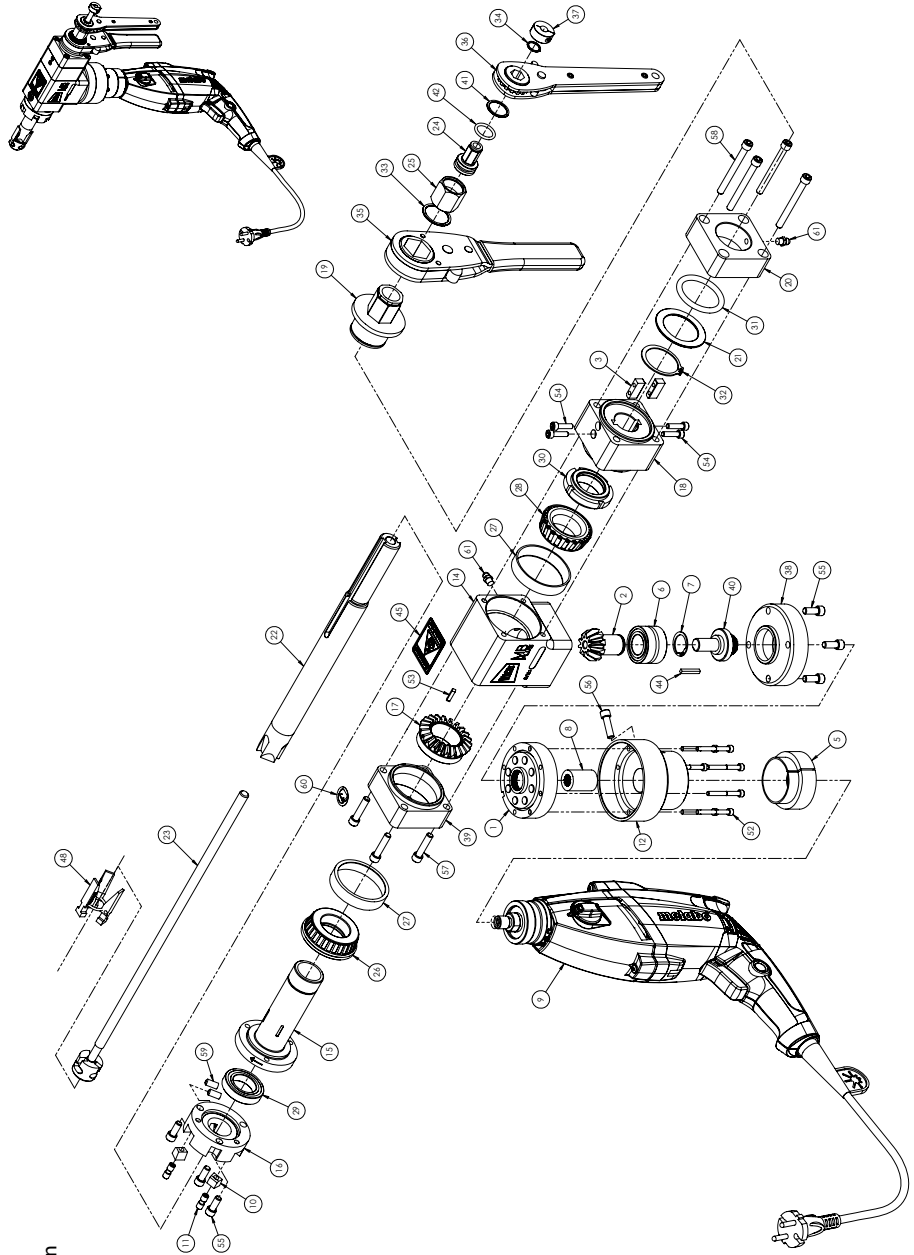

MB Plus 220 V Electric Drive Configuration
71-000-07
OBSOLETE

ITEM	PART NUMBER	QTY.	DESCRIPTION
1	11-1033-00	1	GEARBOX, BINARY OUTPUT
2	16-3072-00	1	GEAR PINION
3	16-3074-00	2	KEY MANDREL
4	19-0340-00	1	ADAPTER MOUNT
5	19-0340-00 REV. 02S	1	ADAPTER MOUNT
6	26-2947-00	1	BEARING, RING, INTERNAL
7	26-2948-00	1	BEARING, RING, EXTERNAL
8	26-1242-02	1	COUPLING NUT
9	30-0311-02	1	MOTOR, METAL 220V
10	30-0311-00	1	MOTOR, METAL 220V
11	70-2033-00	2	SCREW, DIFFERENTIAL
12	70-2034-00	2	SCREW, DIFFERENTIAL
13	70-2035-00	2	SCREW, DIFFERENTIAL
14	71-1001-00	1	HOUSING, AIR BEARING
15	71-1002-00	1	SHAFT MAIN
16	71-1003-00	1	HOUSING, AIR BEARING
17	71-1004-00	1	GEAR SHAFT SMALL
18	71-1008-01	1	HOUSING, KEY
19	71-1010-01	1	HOUSING, FEED NUT
20	71-1011-01	1	WASHER
21	71-1012-01	1	WASHER
22	71-1013-02	1	DRUMBAR ASSEMBLY
23	71-1015-02	1	DRUMBAR ASSEMBLY
24	71-1018-02	1	NUT, DRAWBAR
25	71-1019-02	1	NUT, DRAWBAR
26	71-1019-00	1	NUT, COLLAR, ONE SEAL
27	71-1027-00	2	BEARING, CUP
28	71-1028-00	1	SCREW
29	71-1029-00	1	SCREW
30	71-1030-00	1	LOCKWASHER
31	71-1032-01	1	DRING (22H) BINA-N
32	71-1033-00	1	DRING (22H) BINA-N
33	71-1034-00	1	SPRING, SPIRAL BEARING
34	71-1034-01	1	SPRING, SPIRAL BEARING
35	71-1034-01	1	SPRING, SPIRAL BEARING
36	71-1034-01	1	SPRING, SPIRAL BEARING
37	71-1037-00	1	UTL-16 COLLAR
38	71-1037-00	1	UTL-16 COLLAR
39	71-1050-00	1	CAP, FRONT BEARING
40	71-1051-00	1	SHAFT OUTPUT
41	71-1052-00	1	SHAFT OUTPUT
42	71-1057-00	1	DRING (11H) BINA-N
43	71-1059-00	1	ME FISH FOAM INSERT (NOT SHOWN)
44	71-1062-00	1	ME FISH FOAM INSERT (NOT SHOWN)
45	71-1062-00	1	ME FISH FOAM INSERT (NOT SHOWN)
46	71-1400-01	1	LEG, SET ID., 1/8" (NOT SHOWN)
47	71-1400-01	1	LEG, SET ID., 1/8" (NOT SHOWN)
48	71-1400-03	1	LEG, SET ID., 1/8" (NOT SHOWN)
49	71-1400-04	1	LEG, SET ID., 1/8" (NOT SHOWN)
50	90-0001-15	2	SPRING, SPIRAL BEARING
51	90-0001-15	2	SPRING, SPIRAL BEARING
52	90-0001-15	2	SPRING, SPIRAL BEARING
53	90-0001-15	2	SPRING, SPIRAL BEARING
54	90-0001-06	4	SPRING, SPIRAL BEARING
55	90-0001-06	4	SPRING, SPIRAL BEARING
56	90-0001-06	4	SPRING, SPIRAL BEARING
57	90-0001-06	4	SPRING, SPIRAL BEARING
58	90-0001-25	4	SPRING, SPIRAL BEARING
59	90-0001-25	4	SPRING, SPIRAL BEARING
60	90-0001-25	4	SPRING, SPIRAL BEARING
61	90-0001-25	4	SPRING, SPIRAL BEARING
62	90-0001-25	4	SPRING, SPIRAL BEARING
63	90-0001-25	4	SPRING, SPIRAL BEARING
64	90-0001-25	4	SPRING, SPIRAL BEARING
65	90-0001-25	4	SPRING, SPIRAL BEARING

MAX. OPERATING WEIGHT: 16.9 kg (37.2 lbs)
 MAX. OPERATING FORCE: 220 V AC
 EXTERNAL DIMENSIONS: 24.25" X 19.49" X 6.68"
 (0.67 m X 0.49 m X 0.17 m)

Chapter 9

Accessories and Spare Parts

TOOLING

Table 1: Facing Tools

Part No.	Description
26-410-02	Standard facing tool
26-410-03	High-range facing tool
26-410-04	Carbide-tip facing tool

Table 2: Bevel Tools

Part No.	Description
70-700-00	37.5° bevel tool
70-703-00	37.5° combination with 375 land
26-411-01	37.5° low-range bevel tool
26-411-02	37.5° medium-range bevel tool
26-411-03	37.5° high-range bevel tool
26-411-04	37.5° carbide bevel tool
26-713-00	20° 3/32" radius "J" bevel tool for 1.35"-4.00" I.D. (use with 26-410-02 facing tool for 0.030" land extension)

In This Chapter

TOOLING

ACCESSORIES

Table 3: Combination Bevel and Facing Tools

Part No.	Description
26-413-01	37.5° low-range universal beveling and facing tool
26-413-02	37.5° high-range universal beveling and facing tool

Table 4: Counterbore Tools

Part No.	Description
70-702-00	Reverse 37.5° tool
26-412-01	Low-range I.D. deburring tool
26-412-02	Medium-range I.D. deburring tool
26-412-03	High-range I.D. deburring tool
26-426-00	30° taper counterbore and facing tool

ACCESSORIES

Table 5: MB Plus Accessories

Part No.	Description
71-401-00	Extender kit to increase range to 3.0" I.D.
71-400-01	1.00"-1.32" leg set
71-400-02	1.25"-1.56" leg set
71-400-03	1.49"-1.80" leg set
71-400-04	1.73"-2.05" leg set
71-400-05	1.98"-2.30" leg set
71-400-06	2.22"-2.55" leg set
71-400-07	2.47"-2.79" leg set
71-400-08	2.72"-3.04" leg set
71-402-00	MB Plus ratchet assembly
71-403-00	MB Plus spare parts kit

Chapter 10

Ordering Information

.....

To place an order, request service, or get more detailed information on any E.H. Wachs products, call us at one of the following numbers:

U.S. 800-323-8185
International: 847-537-8800

You can also visit our Web site at:

www.ehwachs.com

ORDERING REPLACEMENT PARTS

When ordering parts, refer to the drawings and parts lists in Chapter 8. Please provide the part description and part number for all parts you are ordering.

REPAIR INFORMATION

Please call us for an authorization number before returning any equipment for repair or factory service. We will advise you of shipping and handling. When you send the equipment, please include the following information:

- Your name/company name
- Your address
- Your phone number
- A description of the problem or the work to be done.

In This Chapter

ORDERING REPLACEMENT PARTS

REPAIR INFORMATION

WARRANTY INFORMATION

RETURN GOODS ADDRESS

Before we perform any repair, we will estimate the work and inform you of the cost and the time to complete it.

WARRANTY INFORMATION

Enclosed with the manual is a warranty card. Please fill out the registration card and return to E.H. Wachs. Retain the owner's registration record and warranty card for your information.

RETURN GOODS ADDRESS

Return equipment for repair to the following address.

E.H. Wachs
600 Knightsbridge Parkway
Lincolnshire, Illinois 60069 USA



600 Knightsbridge Parkway • Lincolnshire, IL 60069
847-537-8800 • www.ehwachs.com